

CCT College Dublin

ARC (Academic Research Collection)

ICT

Winter 2023

Unlocking the Pragmatics of Emoji: Evaluation of the Integration of Pragmatic Markers for Sarcasm Detection

Niamh Farnham
CCT College Dublin

Follow this and additional works at: <https://arc.cct.ie/ict>



Part of the [Computer Engineering Commons](#)

Recommended Citation

Farnham, Niamh, "Unlocking the Pragmatics of Emoji: Evaluation of the Integration of Pragmatic Markers for Sarcasm Detection" (2023). *ICT*. 43.

<https://arc.cct.ie/ict/43>

This Capstone Project is brought to you for free and open access by ARC (Academic Research Collection). It has been accepted for inclusion in ICT by an authorized administrator of ARC (Academic Research Collection). For more information, please contact debora@cct.ie.

Unlocking the Pragmatics of Emoji: Evaluation of the Integration of Pragmatic Markers for Sarcasm Detection

Niamh Farnham

A Thesis Submitted in Partial Fulfilment
of the requirements for the
Degree of
Master of Science in Data Analytics



August 2022

Supervisor: Marina Iantorno

Acknowledgements

The completion of this work could not have been possible without the staff of CCT College Dublin. Our programme coordinator Dr. David McQuaid who has delivered engaging classes and has gone above and beyond to ensure our learning was a valuable and enjoyable experience. My supervisor Marina Iantorno provided guidance and reassurance to me throughout the course of this work also. Each of the teaching faculty, library staff other facilitators also have had an invaluable role to play in the learning and development which is reflected in this work. Their contributions are sincerely appreciated and gratefully acknowledged.

I would like to extend thanks to each of my classmates who have played their part to ensure classes were engaging, provided an environment where we could each support each other during our learning and development and sharing in the achievements and challenges faced along the way. You have all undoubtedly helped me reach this point, for which I am very grateful.

Finally, I would like to acknowledge my family, friends and boyfriend who have each supported me in this process. You have all been tremendously patient and encouraging throughout the challenges I have encountered along the way, although I'm sure you're looking forward to talking about emojis less soon!

Table Of Contents

1 Abstract	xiii
2 Introduction	xiv
3 Research Problem and Statement of Objectives	1
3.1 Problem Definition.....	1
3.2 Research Objectives.....	1
3.3 Delimitation.....	2
4 Literature Review	3
4.1 Theories of Emotion Classification	3
4.1.1 Basic Theory	3
4.1.2 Dimensional theory	4
4.2 Application of Emotion Theory in Data Analytics	5
4.2.1 Basic Theory	5
4.2.2 Dimensional Theory.....	6
4.2.3 Comparison of Theories.....	6
4.3 State-Of-The-Art Text-Based Sentiment Analysis	7
4.4 Sarcasm Detection.....	8
4.4.1 Text-Based Sarcasm Detection	9
4.4.2 Survey of Strategies for Sarcasm Detection	10
4.5 Use of Emojis	14
4.5.1 Emoji Sentiment Classification – Algorithmic Annotation	14
4.5.2 Emoji Sentiment Classification – Manual Annotation	15
4.6 Viability of Emojis to Improve Sarcasm Detection.....	15
4.7 Chapter Conclusion.....	16
5 Lexical Study of Emojis	18
5.1 Dataset Selection.....	18
5.1.1 Basic Emotional Theory	18

5.1.2 Dimensional Theory.....	18
5.2 Definition of Sentiment Parameters.....	18
5.2.1 Basic Emotional Theory.....	18
5.2.2 Dimensional Theory.....	21
5.3 Emoji Feature Extraction.....	24
5.3.1 Use of Emotion Vocabulary Embeddings.....	24
5.3.2 Word Vectors of Basic Emotion Words.....	25
5.3.3 Binary Word Association Lexicon.....	26
5.3.4 Word-Emotion Intensity Lexicon.....	26
5.3.5 Results.....	27
5.4 Sentiment-Aware Vector Space Modification.....	27
5.4.1 Evaluation Parameters.....	29
5.4.2 Results.....	29
5.5 Emoji Sentiment Prediction – Basic Theory.....	33
5.5.1 Data Preparation.....	33
5.5.2 Model Selection.....	33
5.5.3 Model Evaluation.....	34
5.6 Emoji Sentiment Prediction – Dimensional Theory.....	36
5.6.1 Results and Methodology Evaluation.....	37
5.7 Chapter Conclusion.....	38
6 Pragmatics of Sarcasm.....	39
6.1 Primary Research Methodology.....	39
6.2 Survey Outcomes.....	40
6.2.1 Demographics.....	40
6.2.2 Annotations.....	41
6.3 Statistical Analysis of Pragmatics in Sarcastic Content.....	43
6.3.1 Structural and Sentiment Features.....	43
6.3.2 Context-Based Features.....	47

6.4 Evaluation of Sarcastic Text Labelling Strategies	48
6.4.1 Survey Methodology.....	49
6.4.2 Hashtag Annotation Strategy.....	49
6.5 Chapter Conclusion.....	52
7 Integration of Emoji Pragmatics into Sarcasm Detection.....	54
7.1 Proposed Novel Methodology	54
7.2 Proposed Architecture	55
7.2.1 Model Selection	55
7.2.2 Sentiment-Aware Attention Mechanism	55
7.3 Data Preparation	55
7.3.1 Expansion of Current Training Dataset	55
7.3.1.1 Statistical Evaluation to Identify Aligned Features.....	56
7.3.1.2 Results	59
7.3.2 Data Cleaning	60
7.4 Baseline Model Evaluation	61
7.4.1 Neural Network Selection.....	61
7.4.2 Evaluation Metrics.....	61
7.4.3 Model Performance	62
7.5 Attention Mechanism	63
7.5.1 Architecture	63
7.5.2 Model Performance	65
7.6 Impact of Emojis on Model Performance	66
7.7 Chapter Conclusion.....	67
8 Evaluation	69
8.1 Solution Strengths	69
8.2 Solution Limitations.....	69
9 Future Work.....	71
10 Conclusion	72

11 Appendix.....	74
11.1 <i>Word Vector Selection</i>	74
11.1.1 <i>Consideration of Training Data</i>	74
11.1.2 <i>Word Vector Bias</i>	75
11.2 <i>Word Vector Optimisation Process</i>	75
11.2.1 <i>Optimiser Selection</i>	75
11.2.2 <i>Model Optimisation</i>	77
11.2.3 <i>Normalisation</i>	78
11.3 <i>Basic Theory Regression</i>	79
11.3.1 <i>Feature Scaling</i>	79
11.3.2 <i>Mitigation of Skew in Target Variables</i>	79
11.3.3 <i>Assessment of Components for Model Selection for Basic Theory Regression</i>	80
11.4 <i>Model Development for Basic Theory Regression</i>	81
11.4.1 <i>Data Split</i>	81
11.4.2 <i>Models Evaluated</i>	81
11.4.3 <i>Target Variable Format Selection</i>	83
11.4.4 <i>Model Optimisation</i>	83
11.4.5 <i>Hyperparameter Tuning</i>	83
11.4.6 <i>Cross-Validation</i>	83
11.4.7 <i>Dimensionality Reduction</i>	84
11.4.8 <i>Model Evaluation</i>	84
11.4.9 <i>Neural Network Evaluation</i>	84
11.4.9.1 <i>Model Selection</i>	84
11.4.9.2 <i>Performance Evaluation</i>	88
11.5 <i>Dimensional Theory Regression</i>	89
11.5.1 <i>Selection of Pre-Trained Models</i>	89
11.5.2 <i>Evaluation of Architectures in Literature for Sentiment Regression</i>	89
11.6 <i>Survey Components</i>	94
11.6.1 <i>Harm and Risk Assessment</i>	94

11.6.2 Participant Sampling Strategy.....	96
11.6.3 Sourcing Participants.....	97
11.6.4 Survey Questions	97
11.6.5 Survey Design	102
11.7 Statistical Tests Used.....	104
11.7.1 Selection Methodology.....	104
11.7.2 Statistical Tests Used.....	105
11.8 Pragmatic Features Evaluated	106
11.9 Topic Modelling Process	107
11.9.1 Data Preparation.....	107
11.9.2 Models Assessed.....	110
11.9.3 Model Selection and Evaluation	111
11.9.4 Results	113
11.10 Sarcasm Detection Model	115
11.10.1 Data Preparation – Twitter Specific Text Features.....	115
11.10.2 Data Preparation – Emoji Features	115
11.10.3 Data Preparation – Grammatical Features	116
11.10.4 Model Selection for Sarcasm Detection.....	117
11.11 Data Permissions.....	118
11.11.1 Primary Data	118
11.11.2 Secondary Sources.....	118
11.12 Survey Responses	123
12 References	283

List of Figures

Figure 1 Tweet located using #fun in a sarcastic context. Methodology of (Saravia et al., 2021) labels this as content expressing joy.....	5
Figure 2 Fine-Grained Classification methodology of the recursive neural tensor network proposed by Socher et al. (2013).....	8
Figure 3 Cluster analysis of basic emotions on a 2D dimensional theory sentiment plot.....	19
Figure 4 2D dimensional theory sentiment plots. In each case marker size is proportional to the degree of affinity of the emoji to the respective basic emotion. Joy is the basic emotion most affiliated with positive emojis, but results show trust to also be affiliated with emojis of positive sentiment. Sadness, disgust, fear and anger are linked more significantly to negative sentiment emojis – such an outcome is intuitive and provides evidence of agreement between theories in this use case. Surprise and anticipation are less inherently tied to polarity of sentiment which is additionally reflected in the visualisation. Such a result may indicate that the increased granularity of basic theory is of particular importance for identification of these emotions.	20
Figure 5 Distribution of polar sentiment scores across several emojis several Unicode blocks.	21
Figure 6 3D emoji sentiment score plot for all emojis in dataset.....	22
Figure 7 Sentiment Scores of 250 most popular emojis against their occurrences in the Emoji Sentiment Ranking dataset using the defined probabilistic method.	23
Figure 8 Degree of Neutrality (Neutral Sentiment Score) against average position of emoji in text. Emojis towards the end of text strings have lower neutrality; a greater degree of arousal per dimensional emotion theory, indicative that emojis towards the end of strings are more frequently used to convey tone or emotion compared to those appearing earlier in the string. This observation is consolidated by the frequency of face emojis, which are intuitively linked to tone and emotion with low neutrality scores at the end of sentences.....	23
Figure 9 Sample of result of emoji sentiment classification using dimensional emotional theory. Coloured bars are proportional to p_+ , p_0 and p_- . Markers (black) represent s . Grey markers represent the limits of the 95% confidence intervals for the s . Note weary face (left) has high confidence that a negative classifier is appropriate, however ghost (right) cannot necessarily be classified as positive with 95% confidence.....	24
Figure 10 Cosine Similarity.....	25
Figure 11 Pearson’s correlation between basic emotion affinity scores to emojis.....	28
Figure 12 Process to select model for basic theory regression task.....	34
Figure 13 Survey responses deconstructed by demographics.	40
Figure 14 Age distribution of Twitter users.	41

Figure 15 Classification results breakdown by gender These parameters were found to have minimal impact on the rates of sarcasm reported in responses.	42
Figure 16 Distribution of labels assignments for each survey response. Where ‘I don’t know’ was selected 15.84% of the time (approximately 1-2 times per survey). Considering only sarcastic and non-sarcastic labels and controlling for unassigned text 68% of respondents answered within 2 responses of a 1:1 ratio, aligning closely with speculative labels.	42
Figure 17 Atypical Feature Identification in Datasets Annotated using Hashtag Strategy by Feature.	58
Figure 18 Atypical Feature Identification in Datasets Annotated using Hashtag Strategy by Subset. .	59
Figure 19 Data cleaning steps for neural network model training.	60
Figure 20 Optimal baseline GRU Model for Sarcasm Detection.	62
Figure 21 Training Profile of Optimal GRU model.	62
Figure 22 Optimal GRU Model for Sarcasm Detection with Attention Layer.	66
Figure 23 3D visualisation of complex loss landscape. The model must be capable of escaping saddle points and local minima to reach the global optimal solution.	76
Figure 24 Word vector optimisation step. Adam optimiser dictates step direction and size, while normalisation ensures the result of each step remains on the plane.	78
Figure 25 Word vector normalisation process. Each vector is adjusted such that its lies at some point on a 3D spherical plane of radius 1. As angles θ and Φ are conserved in the process, sentiment is largely unaffected and strategies for comparison using cosine similarity are still valid.	79
Figure 26 ReLU activation function graph.	86
Figure 27 ELU activation function graph.	86
Figure 28 SELU activation function graph.	87
Figure 29 Swish activation function graph.	87
Figure 30 LSTM unit architecture.	91
Figure 31 GRU unit architecture.	91
Figure 32 Matrix operations to determine attention scores.	93
Figure 33 Architecture and mechanism of transformer model attention layers.	93
Figure 34 Transformer model architecture.	94
Figure 35 Outline of sampling for emoji usage survey questions.	102
Figure 36 Single select radio buttons to collect discrete data. In built logic ensures that responses yield valid output using prompts to ensure only one option can be selected. Text fields may also contain conditional formatting to ensure instructions are followed.	103
Figure 37 Free text field for emoji use questions is populated with a default value of the text string the participant has previously classified as sarcastic or non-sarcastic to improve response quality. This	

enables the participant to insert emojis with ease into the text prompt. The figure displays the desktop version of the survey which features a drop-down menu containing emojis to make responses easier where an emoji keyboard is not available. 103

Figure 38 Process flow chart to determine if data under evaluation is parametric or non-parametric. 104

Figure 39 Selection of Statistical Tests..... 105

Figure 40 Architecture of LDA model..... 110

Figure 41 CNN model architecture for text processing. 117

List of Tables

Table 1 Research methodology summaries for sarcasm detection on twitter.....	11
Table 2 Pearson Correlation scores for all considered prediction methods. Bolded Scores represent the greatest correlation (positive or inverse) observed for the emotion in the respective column, excluding human agreement scores. Average values are reported with respect to absolute correlation.	27
Table 3 Pearson Correlation scores for all considered prediction methods following vector-space modification- method 1.	31
Table 4 Pearson Correlation scores for all considered prediction methods following vector-space modification- method 1. Original emoji vectors and transformed word vectors used.....	32
Table 5 Pearson Correlation scores for all considered prediction methods following vector-space modification- method 2.	33
Table 6 Results of model development process for basic theory regression displaying the best outcomes for each model, correct to three significant figures. The selected optimal model is in bold for each basic emotion. Note that reported metrics are with reference to validation performance..	35
Table 7 Assessment of model accuracy considering the mean values of each basic emotion.....	36
Table 8 Top 10 Most Used Emojis in Survey Results.....	44
Table 9 Statistical Evaluation of Emoji-Based Markers of Sarcasm.	45
Table 10 Statistical Evaluation of Emoji-Based Sentiment Skew in Tweets.....	46
Table 11 Statistical Evaluation of Sentiment Congruence Between Emojis and Text.	46
Table 12 Statistical Evaluation of Text-Based Markers of Sarcasm.	47
Table 13 Topics Identified for Sarcastic and Non-Sarcastic data using topic modelling.	48
Table 14 Statistical Evaluation of Contextual Indicators of Sarcasm.....	48
Table 15 Comparison of Sarcastic Text Features between datasets.	50
Table 16 Baseline for Evaluation of Tweets for Organic Sarcasm Features.....	57
Table 17 Performance Metrics of Optimal GRU Model for Sarcasm Detection on unseen data.	63
Table 18 Performance Metrics of Optimal GRU Model for Sarcasm Detection with Sentiment-Aware Attention Layer on unseen data.	66
Table 19 Performance Metrics of Optimal GRU Model for Sarcasm Detection with Sentiment-Aware Attention Layer on unseen data.	67
Table 20 Summary of hyperparameters assessed.....	77
Table 21 Strategies evaluated to mitigate skew for each basic emotion.	80
Table 22 Results of skewness transformation.	80
Table 23 Neural Network performance evaluation results.	89
Table 24 Survey questions to verify participant eligibility.....	99

Table 25 Survey questions to establish demographics of participants.	100
Table 26 Survey questions about emoji usage.	100
Table 28 Summary of results from topic modelling for best models.	114

List of Acronyms

ANOVA	Analysis of Variance
BERT	Bidirectional Encoder Representations from Transformers
CARER	Contextualised Affect Representations for Emotion Recognition
CNN	Convolutional Neural Network
DNN	Deep Neural Network
ELMo	Embeddings from Language Models
FBCA	Feature-Based Composite Approach
FFN	Feed-Forward Neural Network
FSNN	Fracking Sarcasm using Neural Networks
GDPR	General Data Protection Regulation
GloVe	Global Vectors
GRNN	Gated Recurrent Neural Network
GRU	Gated Recurring Unit
KNN	K-Nearest Neighbours
LDA	Latent Dirichlet Allocation
LSTM	Long-Short Term Memory
MAIRN	Multi-Dimensional Intra-Attention Recurrent Network
NLP	Natural Language Processing
NMF	Non-Negative Matrix Factorisation
NMPI	Normalised Pointwise Mutual Information
PMI	Pointwise Mutual Information
RCCSD	Role of Conversation Context for Sarcasm Detection
ReLU	Rectified Linear Unit
RoBERTa	Robustly Optimised BERT Pre-Training Approach
SELU	Scaled Exponential Linear Unit
SVM	Support Vector Machine
URL	Uniform Resource Locator

1 Abstract

Emojis have become an integral element of online communications, serving as a powerful, under-utilised resource for enhancing pragmatic understanding in NLP. Previous works have highlighted their potential for improvement of more complex tasks such as the identification of figurative literary devices including sarcasm due to their role in conveying tone within text. However present state-of-the-art does not include the consideration of emoji or adequately address sarcastic markers such as sentiment incongruence.

This work aims to integrate these concepts to generate more robust solutions for sarcasm detection leveraging enhanced pragmatic features from both emoji and text tokens. This was achieved by establishing methodologies for sentiment feature extraction from emojis and a depth statistical evaluation of the features which characterise sarcastic text on Twitter. Current convention for generation of training data which implements weak-labelling using hashtags or keywords was evaluated against a human-annotated baseline; postulated validity concerns were verified where statistical evaluation found the content features deviated significantly from the baseline, highlighting potential validity concerns for many prominent works on the topic to date. Organic labelled sarcastic tweets containing emojis were crowd sourced by means of a survey to ensure valid outcomes for the sarcasm detection model. Given an established importance of both semantic and sentiment information, a novel sentiment-aware attention mechanism was constructed to enhance pattern recognition, balancing core features of sarcastic text: sentiment incongruence and context.

This work establishes a framework for emoji feature extraction; a key roadblock cited in literature for their use in NLP tasks. The proposed sarcasm detection pipeline successfully facilitates the task using a GRU neural network with sentiment-aware attention, at an accuracy of 73% and promising indications regarding model robustness as part of a framework which is easily scalable for the inclusion of any future emojis released. Both enhanced sentiment information to supplement context in addition to consideration of the emoji were found to improve outcomes for the task.

2 Introduction

Emojis have become a ubiquitous part of our online lives, first appearing in 1999 and their use becoming increasingly commonplace throughout digital communication. Their usage has resulted in an unprecedented evolution in how digital communication occurs, seamlessly integrating images into typography. While natural language processing is a widely utilised and powerful tool in data analytics, contextual understanding, and ambiguity in text still present challenges to these models. Sarcasm is one such source of ambiguity which has been suggested to account for significant limitations in these models, largely due to limited semantic clues due to the short-form nature of online text; the models cannot know that the implied meaning of the text opposes the literal. Additionally, word vectors are largely the sole source of data considered for the purposes of the classification, which limits the scope for pattern recognition in prevalent model architectures such as neural networks. Emojis are widely used for the purpose of establishing tone and sentiment to the reader. This is intuitive to anyone who consumes digital content, however in the domain of NLP, there are few instances of research into the potential for consideration of emojis as a pragmatic indicator in text processing, however literature suggests that this approach has potential. The research problem can be summarised by the following question:

Can the consideration of pragmatic cues from emojis in text improve outcomes for sarcasm detection?

This work aims to evaluate the conventions relating present state-of-the-art sarcasm detection pipelines and build upon these works to address present limitations and validity concerns to generate a robust and viable solution to the task of sarcasm detection.

3 Research Problem and Statement of Objectives

3.1 Problem Definition

The research problem proposed for this work can be clarified using the problem definition model as follows:

Problem Identification: Figurative literary devices such as sarcasm present significant challenges to modern natural language processing models as their identification relies heavily on tone and context including interlocutor relationships which are not captured in models. Emojis are often used to convey tone or sentiment within text, however literature exploring their contribution to sarcasm detection is sparse.

Problem Clarification: Lexical study of emojis in sarcastic text may be a key avenue for exploration to improve upon present state-of-the-art sarcasm detection for natural language processing.

Problem Formulation: Evaluation of emoji pragmatics in sarcastic content compared to literal counterparts may provide additional insight into the tone or context of online content. Integration of these patterns may increase the capacity of natural language processing models to consider these complex linguistic devices for more accurate sentiment analysis outcomes.

3.2 Research Objectives

To address the question, the following objectives are proposed:

Objective 1: Determine optimal emotion classification methodologies with respect to psychological principles and their implementation within a data analytics context for text and emoji classification. Propose feature extraction strategies for emojis which supplement limitations of pragmatic information in text-based analysis.

Objective 2: Establish patterns of statistical significance between text and emoji features which characterise sarcasm in online text. Evaluate present convention with regards to annotation strategy and compile a training dataset representative of organically occurring sarcasm on Twitter.

Objective 3: Propose a novel methodology for sarcasm detection to improve pragmatic understanding of text. Critically evaluate the outcomes of integrating this novel feature into sarcasm detection models.

3.3 Delimitation

An intuitive delimitation for this work relates to the problem definition which dictates that the conclusions drawn may not apply where emojis are not used. The scope of the data used in this work was limited to tweets generated by native or near-native English speakers. While sarcasm is a universal concept worldwide, conclusions drawn on how it is conveyed within text can only apply to the English-speaking population as this work does not consider the possibility of dynamic semiotics of emojis across languages or cultures. The dataset also limits the scope of any conclusions drawn to Twitter data as this work does not assess the consistency in pragmatic patterns across platforms, which may be relevant due to varying limitations and conventions relating to content length, structure and formality of language used.

4 Literature Review

Emojis have undoubtedly become a ubiquitous part of our online lives, first appearing in 1999 and their use becoming increasingly commonplace throughout digital communication. Their usage has resulted in an unprecedented evolution in how digital communication occurs, seamlessly integrating images into typography. While NLP is a widely utilised and powerful tool in data analytics, contextual understanding, and ambiguity in text still present challenges to NLP models. Sarcasm is one such source of ambiguity which has been suggested to account for significant challenges to NLP models, for example, Maynard and Greenwood (2014) suggested that sarcasm accounted for up to a 50% drop in accuracy in their sentiment analysis model. While their dataset contained a disproportionate prevalence of sarcastic content and a small training dataset, the work demonstrates the need for accurate detection tools to aid in NLP tasks. Emojis are widely used with the purpose of establishing tone and clues towards sentiment to the reader. This is intuitive to anyone who consumes digital content in the modern age, however in the domain of data analysis and NLP, there are few instances of research into the potential of consideration of emojis towards the processing of text. This review of present relevant literature aims to establish the viability of consideration of emojis to aid in sarcasm detection through the critical evaluation of state-of-the-art methodologies in sentiment analysis and sarcasm detection.

4.1 Theories of Emotion Classification

The categorisation of emotions presents a challenging question within the field of psychology, with debates on the state-of-the-art found throughout literature. The methodologies employed to achieve such categorisations fall primarily into two classes: basic emotion theory and dimensional theory (Thamm, 2006; Fontaine, 2013) which are fundamentally contradictory. The former initially introduced by Darwin (1872) proposed humans have a limited number of basic emotions which are present to enable fundamental tasks such as survival. These emotions can co-exist to form compound emotions and the degree of arousal for such compound emotions can further add granularity to secondary and tertiary categorisations (Anderson and Adolphs, 2014). While there is little consensus on the quantity or categories of the basic emotions (LeDoux, 1995; Damasio, 1997), broadly speaking all modern research has the same aim; to determine a discrete set of fundamental emotions, each possessing a distinctive neurophysiological signature (Stein and Oatley, 2008; Keltner *et al.*, 2019).

4.1.1 Basic Theory

Robert Plutchik, an initial prominent figure within the field found eight categories; anger, fear, disgust, surprise, anticipation, trust, and joy (Plutchik, 1962; Imbir, 2017). His methodology surrounded the identification of emotions which arise from a behaviour with high survival value- for example fear

stimulating the fight-or-flight response (LeDoux, 2012; Kravitz and Fernandez, 2015). While this adhered to the basic definition of the model, manual selection of emotions may have resulted in bias—an observation which could be concluded from his own work which stated that the nature of the individual has a significant impact on their experience of compound emotions and thus it appears pertinent to question whether the experiences of Plutchik contributed to his conclusions within this work. Later research developed this theory to increase objectivity in classifications, adding consideration of physiological manifestations of such emotions which must have unique and explainable characteristics (Keltner *et al.*, 2019). Ekman (1992) proposed seven emotions using this method, however, later works argue overlap in several categorisations. Jack, Garrod and Schyns (2014) found that disgust and anger share a wrinkled nose and fear and surprise share raised eyebrows and thus the proposed emotions were reduced to six. Additionally, the theory postulates that the emotions must be the result of survival instinct. Research in the field debate the inclusion of anger and disgust in addition to fear and surprise as separate entities respectively as these emotions are thought to have branched due to social functions therefore any works identifying such emotions separately may be invalid (Mansourian *et al.*, 2016). The most widely utilized groupings of basic emotions are the six primary emotions proposed by Ekman: anger, sadness, joy, disgust, fear and surprise and an alternative consisting of four: fear, anger, joy and sadness (Izard, 2007; Gu *et al.*, 2015; Mansourian *et al.*, 2016; Wang and Pereira, 2016), first presented by Izard who stated “people need the category label *fear* to explain flight to one another for safety, *anger* to explain the frustration of blocked goal responses, *joy* to explain the pride of achievement and *sadness* to explain the experience of life-changing loss”.

4.1.2 Dimensional theory

The alternative framework, dimensional theory places emotions at unique points on a two-dimensional plane classifying them based on valence and arousal (Russell, 1980; Russell and Barrett, 1999; Barrett and Russel, 2015). This model presents emotions in a more fluid manner, representing transitory neuropsychological states converse to the discrete categorizations in basic theory, and addresses a limitation with regards to overlapping characteristics between emotions. Dimensional theory is preferable in cases where greater flexibility and consideration to the nuance of emotional experience between individuals adds value, however a majority of literature using this theory relies on self-classification of emotions on scales representing valence and arousal making classification of ‘like’ emotions across a population difficult due to bias of subjects, although this is an intuitive limitation when considered in the context of the question itself. The more rigid definitions of emotions in basic theory may be advantageous for comparison across a population as they are more objective, even when self-reporting is utilized.

4.2 Application of Emotion Theory in Data Analytics

4.2.1 Basic Theory

In the domain of data analytics, fine-grained emotion classification is a widely utilized tool in natural language processing, however the principles of either emotion theory seem to be under-utilized. Discrete emotion labels representing primary, secondary, and tertiary emotions are common, however the effects of the subjectivity of such categories are evident with poor generalisation and lack of agreement in label assignment where multiple subjects assign labels to the same content. The core goal of basic emotional theory is to address such a limitation and with clearly differentiated discrete labels thus addressing these limitations directly. The largest dataset for fine-grained emotion classification 'GoEmotions' is a human-annotated dataset created from Reddit content, with 27 emotion categories (Alon and Ko, 2020). Subjectivity of classifications is evident in the discussion of outcomes when assigned labels were compared across subjects, where related emotions were relatively evenly distributed across the labels. Google argues this as evidence of efficacy of the model, however in 6% of cases no inter-annotator agreement was found (which was defined in this case as two or more of the annotators) even when multiple classifications were permissible to be assigned, which indicates limitations in the label classes, most likely due to the high dimensionality, as this shortcoming was not observed for datasets where lesser dimensionality was used. It was also noted that the work has poor ability to generalise- with a notable reduction in performance when predictions are made for text sourced outside of Reddit. Saravia et al. (2021) use the 8 emotions outlined by Plutchik, while the reduced dimensionality showed improvements in generalisation due to reduced subjectivity for assignments, it should be noted that the assignment of classifications was based on vocabulary found in hashtags within tweets, which essentially condenses more subjective assignments into the more objective classifications made by the Plutchik model and fails to address the nature of hashtag use- hashtags are not always used to consolidate emotion found in the text, conversely they are often employed to convey sarcasm amongst other figurative devices (Kunneman *et al.*, 2015; Sykora, Elayan and Jackson, 2020).

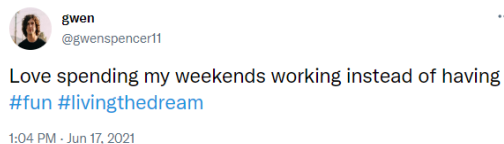

Figure 1 Tweet located using #fun in a sarcastic context. Methodology of (Saravia et al., 2021) labels this as content expressing joy.

Works utilizing the four and six basic emotions cite fewer limitations due to subjectivity of their categories regardless of the methodologies used to assign labels (Zheng, Mountstephens and Teo, 2020; Pandey, 2021), consolidating evidence that the present state-of-the-art basic emotion models

are successful in their aim of creating discrete classifications of emotions which in the context of data analytics is evidenced to improve outcomes in fine-grained emotion classification tasks.

4.2.2 Dimensional Theory

The dimensional theory of emotion classification is less prominent in natural language processing, however observations by Grgić, Podobnik and Carvalho (2022) provide proof of concept and results which indicate the methodology generalises well between different text sources thus this method may be preferable where generalization is a concern which applies in some cases utilizing discrete emotion categories (Alon and Ko, 2020). This work presents a three-dimensional plane, where the final dimension representing 'expectancy'. This final dimension could not be identified in any literature in the domain of psychology researching dimensional theory, however there is evidence suggesting the degree of anticipation may have an impact on emotion, so its inclusion is not necessarily illogical (Castelfranchi and Miceli, 2018). Rao (2019) highlights the limitations of a dimensional theory approach for sentiment analysis using a simplified one-dimensional scale, finding natural language processing models have a bias towards classifying at the extremes of the scale.

4.2.3 Comparison of Theories

No work comparing the two models on a 'like' problem set could be identified for use in natural language processing, however it is likely that the preferable model would be context-based. Optimal practice during use of discrete emotion categories involves the use of one of the emotion groupings proposed in basic theory to facilitate valid annotation of training data as subjectivity of categories is minimized. For use of continuous scales from dimensional theory best practice is less evident due to the limited relevant work available however, the annotation of training data would be greatly influential on the results. Random sampling during annotation would ensure preceding data does not impact the labels assigned on average where a continuous scale to rank emotions is used due to the primacy and recency effects (Fang, van Kleef and Sauter, 2018; Cowen *et al.*, 2019), which would have a greater impact here than in cases with more objective discrete categories. Manual annotation of training data is widely used across both models and thus results are subject to human perceptions and bias (Ekman, 2020; Feldborg *et al.*, 2021). While bias is a limitation with regards to validity management, the discussion may be more nuanced in this context as the bias mirrors that which exemplifies the human experience of emotion therefore may not have detrimental effects on results. Mitigation of inaccurate labelling to ensure relative homogeneity across annotators would involve all subjects being briefed to ensure an understanding of the definition of each class. Labels should be applied by multiple subjects, monitoring inter-iterator agreement (Mesevage, 2021). Text where no consensus is achieved and annotators who consistently output results contrary to the majority may

be unreliable and removal of such information from the dataset may be necessary. Random sampling during annotation would ensure preceding data does not impact the labels assigned on average where a continuous methodology of assignment is used.

4.3 State-Of-The-Art Text-Based Sentiment Analysis

State-of-the-art text-based sentiment analysis is generally trending toward increased granularity. Context extraction from text was cited as a key area to improve upon current NLP models' capacity to achieve this (Acheampong, Wenyu and Nunoo-Mensah, 2020). Yusof, Mohamed and Abdul-Rahman (2019) evaluated the effects of the consideration of both contextual and semantic information which resulted in improved outcomes in more ambiguous cases, compared to a control which considered keyword sentiment only. Katz, Ofek and Shapira (2015) consolidated these observations, expanding upon research into the scope of the improvement. Their findings suggest that the most significant improvements were observed in cases of noisy and unstructured text, but improvements were also observed in more structured text.

Present literature classifying text into emotion-based sentiment categories deploy a range of strategies. Lee, Teh and Pak (2021) defined 12 emotions across a scale with respect to their polarity. The study was successful in correlating word usage to emotions but limitations for this work noted that text in isolation was not the most effective method to achieve this and greater accuracy may be achieved with the inclusion of additional parameters. Authors acknowledged that their approach could not account for the presence of sarcasm, which is common in the context of the data collected. Nandwani and Verma (2021) cited similar limitations of their work, classifying text into 6-8 emotion categories using text only. Of the models proposed, the most successful achieved approximately 94% accuracy, with sarcasm and irony being cited as limitations of their model also. Schuff et al. (2017) showed similar limitations but proposed an interesting strategy to towards improving reliability of labels used in model training; a chance-corrected measure of inter-annotator agreement was used to assess the reliability of the labels used in the training dataset, reducing the impact of inaccurate or labels representing outlier opinions.

The first identified instance of fine-grained sentiment analysis in this review carried out by Socher et al. (2013) trained a recursive neural tensor network, obtaining unremarkable accuracy of 46%. This was improved upon by Peters et al. (2018) which obtained 55% accuracy using a Bi-Attentive Classification Network on the same dataset. This model is the first to attempt to use semantics to improve accuracy using ELMo embeddings and the degree of improvement upon previous state-of-the-art indicates that semantics play a significant role in accuracy for such a task. Improvement upon semantic embeddings largely dictate developments in fine-grained sentiment analysis at present.

While neural language models have made significant improvements, deep learning models have greater capacity to capture semantic context from text and thus achieve greater accuracy for fine-grained sentiment analysis. The BERT model is one such example of state-of-the-art, with its success attributable to the vast and varied training corpus enabling good generalisation abilities and its bidirectional transformer architecture allowing the capture of dependencies in the forward and reverse direction increasing contextual understanding. Masked language modelling was used during training; a sample of tokens in a sequence were masked and the model was trained to predict them based on the surrounding tokens- this encouraged a deeper understanding of language syntax and semantics. Throughout the analysis of such state-of-the-art works, the limitations associated with figurative linguistic devices were regularly cited.

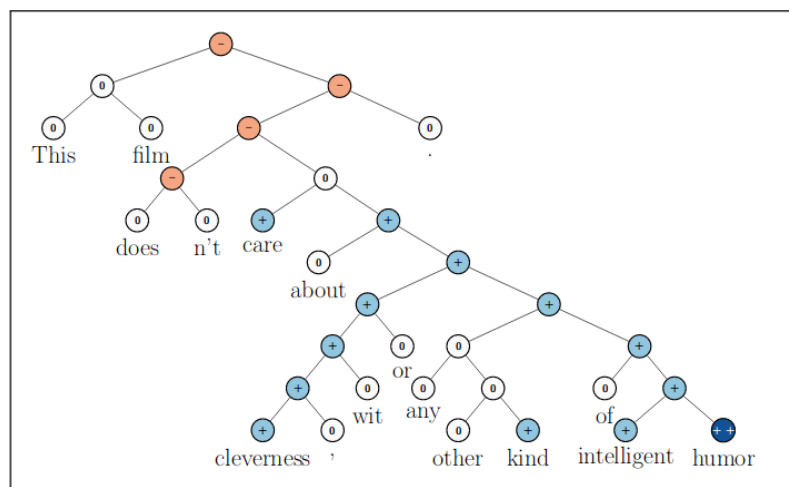

Figure 2 Fine-Grained Classification methodology of the recursive neural tensor network proposed by Socher et al. (2013).

4.4 Sarcasm Detection

Figurative linguistic devices refer to any text which possesses a sub-context beyond its literal meaning aiming to add nuance, context, or tone Peters (2022). Examples of such devices include sarcasm, irony, hyperbole, and metaphor. As these devices rely heavily on implied meaning opposing the literal, detection using NLP presents a challenging problem set.

Sarcasm is typically associated with the expression of frustration, anger, or annoyance and its delivery relies heavily on situational awareness or context (Airaksinen, 2020). Structural markers of sarcasm vary significantly across languages both in terms of importance and the structure itself, with languages containing highly structured, codified systems of formality in speech such as Japanese and Korean being more readily identifiable through structure in addition to context as sarcasm is often conveyed through the exploitation of such structures (Wetzel, 2004). Sarcasm has more methodical usage in these languages, where deliberate misuse of verbs relevant to the interlocutor and situation are used making structural identifiers more useful for identification purposes (Brown, 2013; Iseli, 2023).

Conversely, English does not distinguish the relative status of those involved in an exchange and thus honorific sarcasm is not observed. There is little research which has been found to identify sarcasm based on structural markers of text in English, with the split interrogative structure being only marker identified during this review which does not make up a significant proportion of sarcasm found in the English language. The structure of the device is composed of a question which is followed by a tag representing a possible answer, for example: *Who do you think you are, my mother?* (Michaelis and Feng, 2015; Botteri, 2016). While this structure is disproportionately represented in sarcastic text, it is only indicative of sarcasm where the tag is an unexpected response to the question posed. This structure also has a sincere use case where it portrays ongoing performance or proposing future outcomes of current efforts (Clark and Fox Tree, 2002; Michaelis and Feng, 2015). External to the sparse structural markers identified, sarcasm is overwhelmingly identified through cues in body language and tone, which are absent in text analysis (Persicke *et al.*, 2013; Hiremath and Patil, 2021), making its identification within text a challenge referred to as the “Achilles’ heel” of NLP tasks in literature (Majumdar *et al.*, 2021).

There are indications that these challenges may be related to the difficulties faced in generating a strict definition for sarcasm; literature largely concludes that a single overarching definition of sarcasm cannot be determined. In an academic context, the definition often relates to instances where the quality maximum is violated in pragmatic theory (Grice, 1975). Nuances have been added to such definition in some works for example, Hadi (2013) define sarcasm as any utterance which ‘echoes’ an expectation that has been violated and Sperber and Wilson (1981) add to this with their explanation; the speaker of sarcasm is not performing genuine speech, but rather pretending to with an expectation that the audience will recognise this act. Further expansion of the definition adds an ‘allusional pretence’ which dictates that the sarcasm must not only be pragmatically insincere but additionally must imply a failed expectation or deviation from the norm (Kumon-Nakamura, Glucksberg and Brown, 1995). While these definitions do provide a baseline set of characteristics, there is an element of subjectivity in all definitions identified and thus definition-based sarcasm identification models are not optimal or commonly presented. Most modern research into sarcasm identification where manual annotation of sarcastic content is carried out relies on the individuals intuitive understanding of the concept; a methodology which is largely viewed as effective considering sarcasm is socially determined.

4.4.1 Text-Based Sarcasm Detection

In text, context is widely regarded as the most important factor identification of sarcasm for humans. Social and interpersonal factors are known to affect the use and interpretation of sarcasm (Gibbs, 1994, 2003; Giora, 2012). One such example of this observed by Kreuz (2018) found that with

increasing familiarity between individuals the frequency of use of sarcasm increased. Additionally, when interlocutors share increased commonality, they can more readily identify sarcasm (Kreuz and Link, 2002). The two effects are tied together by the *principle of inferability* which is a widely accepted theory stating that speakers only employ sarcasm when there is evidence that receivers will correctly identify it (Kreuz and Roberts, 1995). While the nature of sarcasm use by humans is clearly explained by the conclusions in these works, they also highlight the nature of the limitations of sarcasm detection in an online textual context; machine learning cannot necessarily know the relationships between interlocutors as the receiver of information is often undetermined when the text is generated meaning primary mechanisms for detection are not viable. This effect is further amplified in short form text such as tweets or reviews, where character constraints are tight thus context is limited. Additionally, tweets often exist in sequence where sarcasm may only be evident in the context of the overall thread, resulting in excluded context where tweets are considered as individual entities. Filatova (2012) presents a ‘crowdsourced corpus’ of sarcastic and non-sarcastic pairs of Amazon reviews. The paired reviews were re-classified by new annotators, where context of the product and star rating were provided, and by a secondary population where context was not provided. With increasing availability of context there was a significant increase in agreement between participants. While this has a positive implication, no assessment of the corpus on ability to classify sarcasm programmatically was carried out. The work concluded that the most significant limitation of sarcasm identification related to absence of context rather than differing definitions of sarcasm between participants; with such an effect being increasingly pronounced in shortform text. In an online context, short-form text and sarcasm are highly interlinked, presenting a dichotomy; context is increasingly limited but also more important.

4.4.2 Survey of Strategies for Sarcasm Detection

Regardless of the challenges presented, the topic of text-based sarcasm detection is a vibrant area of research in the domain of data analysis. Table 1 summarizes present methodologies found across literature.

Table 1 Research methodology summaries for sarcasm detection on twitter.

Author(s)	Year	Labelling approach	Algorithm
Zhang, Zhang and Fu	2016	Sarcastic and non-sarcastic	Bi-Directional Gated Recurrent Neural Network (GRNN)
Abercrombie and Hovy	2016	Sarcastic and non-sarcastic	Logistic Regression
Ghosh and Veale	2016	Sarcastic and non-sarcastic	CNN, LSTM, DNN
Tungthamthiti, Shirai and Mohd	2016	Sarcastic and non-sarcastic	SVM
Saha, Yadav and Ranjan	2017	Polarity: Positive, negative, and neutral	Naïve Bayes
Tay et al.	2018	True and false	Multi-Dimensional Intra-Attention Recurrent Network (MIARN)
Ren, Ji and Ren	2018	Polarity: Positive, negative	CNN
Parmar, Limbasiya and Dhamecha	2018	Polarity: Positive, negative	Feature-based Composite Approach (FBCA)
Parde and Nielsen	2018	Polarity: Positive, negative	Naïve Bayes
Bouazizi and Ohtsuki	2019	Polarity: Positive, negative, and neutral	Random Forest
Sharma et al.	2019	Sarcastic and non-sarcastic	LSTM
Kumar and Garg	2019	Sarcastic and non-sarcastic	Naïve Bayes, Gradient Boosting and Random Forest

Garg and Duhan	2020	Positive, negative Sarcastic and non- sarcastic	SVM
Khotijah, Tirtawangsa and Suryani	2020	Sarcastic and non- sarcastic	LSTM
Sykora, Elayan and Jackson	2020	Sarcastic and non- sarcastic	Random Forest
Dutta and Mehta	2021	Sarcastic and non- sarcastic	CNN-LSTM
Eke, Norman and Shuib	2021	Sarcastic and non- sarcastic	LSTM
Moore and Mago	2022	Sarcastic and non- sarcastic	DNN
Prasanna, Shaila and Vadivel	2023	Sentence structure, Polarity: Positive, negative	Decision tree
Pandey and Singh	2023	Sarcastic and non- sarcastic	LSTM
Sharma et al.	2023	Sarcastic and non- sarcastic	DNN

Of the surveyed literature, there is no consensus drawn on the ideal classifier model for the task, however the majority of works have converged on the use of ‘sarcastic’ and ‘non-sarcastic’, or some variation for data annotation. While the labelling convention is unproblematic, the convention for collection of such annotated data presents validity concerns. Weak labelling using hashtags such as #sarcasm and #irony or other variations are utilised to sourced annotated data. With tweets from celebrities and influencers who are anxious to avoid misinterpretation of their content by their audience being overrepresented (Tsur, Davidov and Rappoport, 2010; González-Ibáñez, Muresan and Wacholder, 2011; Bamman and Smith, 2015). Observations within these works also show that these hashtags are sometimes used where sarcasm is not intended, lending further criticism to the method. Sarcasm by nature is aligned with negative and often offensive sentiment, which is contrary to intent

of these tweets designed to engage audiences in a relatable and non-offensive manner. Additionally, use of such hashtags to label sarcasm is not the primary way sarcasm is presented on the platform, thus models trained using datasets with are likely to have an inherent bias towards a certain presentation of sarcasm. Abercrombie and Hovy (2016) postulate that the nature of the sarcasm in these datasets is disproportionately subtle to avoid negative reception by the audience. The surveyed literature seldom discusses generalisation capabilities of their proposed models, however where this is a consideration outside of Twitter data containing highly unambiguous hashtags as labels, the outlook is consistently poor. No evidence could be identified which supports any theory that sarcasm is expressed fundamentally differently on Twitter, therefore there is strong indication that the root cause of such an observation is related to the nature of the data annotation. Sykora, Elayan and Jackson (2020) evaluated one such dataset which sourced tweets in this manner and found just 15% of tweets annotated as sarcastic to have accurate labels and highlighted concerns regarding the validity of reported model accuracies within studies utilising this annotation strategy. Authors discuss the need for more critical evaluation of sentiment analysis results in future work in addition to new data preparation methodologies. Abercrombie and Hovy (2016) propose an improved data sampling strategy which aims to account for the principles of inferability through use of tweet threads and avoids use of tweets containing highly unambiguous hashtags thus addressing primary limitations of modern sarcasm detection research. This work developed a hand-annotated corpus of contextualised sarcastic and control (non-sarcastic) twitter exchanges which outperformed the control dataset, indicating potential to improve upon present conventions which have significant validity concerns with regards to dataset relevance. However, the work acknowledges that further efforts are necessary to assess the ability of the method to improve generalisation of sarcasm detection in text. A notable point discussed which is supported by others within both NLP (Filatova, 2012) and cognitive psychology (Utsumi, 2000; Gibbs and Colston, 2007) domains agree that additional context aids in the identification of sarcasm by humans. Such context can involve an understanding of the relationship between interlocutors or information about the behaviours of the individual outside of the scope of the specific interaction. Availability of such information increases agreement between annotators and accuracy in manual annotation- this may be essential to state-of-the-art annotation in this context and improve sarcasm detection outcomes overall.

Three text-based sarcasm detection frameworks were highlighted as state-of-the-art through this section of the review:

- Fracking Sarcasm using Neural Networks (FSNN) which utilises a CNN, LSTM and DNN in combination to detect sarcasm on the sentence level (Ghosh and Veale, 2016).

- Contextualized Affect Representations for Emotion Recognition (CARER) uses a multi-layer CNN architecture with a matrix of enriched patterns which preserve semantic relationships between word clusters to detect emotion (Saravia *et al.*, 2021).
- Role of Conversation Context for Sarcasm Detection (RCCSD) which uses conditional LSTM networks with sentence-level attention on conversational context and response (Ghosh, Fabbri and Muresan, 2017).

The survey of present methodologies indicates that current state-of-the-art sarcasm detection methods are converging on a single data annotation convention, which presents concerns regarding the accuracy of outcomes of the resulting models, and thus any reports of accuracies where this annotation methodology has been utilised should be viewed with scepticism with regards to their true ability to detect sarcasm. Outcomes indicate that sarcasm detection may be achievable using many methods, however the accuracy which can be achieved is not necessarily clear. Notably, punctuation, case-shifting or embedded pictographs such as emojis were universally removed during data pre-processing in all cases assessed in this section of the review. This is contrary to expectations as such features are frequently used to convey tone or add context and emotion cues (Briscoe, 1997; Boutet *et al.*, 2021; Hand *et al.*, 2022), which is the primary limitation of sarcasm detection cited in the surveyed literature. Works which add consideration to these features do exist, however this research is sparse. The most successful text-based sarcasm detection approaches each present differing strategies to consider additional context in addition to the text itself- this provides a strong indication that additional context is the key to improvement of these tools in future works.

4.5 Use of Emojis

4.5.1 Emoji Sentiment Classification – Algorithmic Annotation

Research into the impact of emojis on the perception of sentiment in text is an emerging research field at present both in the context of NLP and linguistics. The classification of the sentiment of the emoji itself is essential for such a task, with official Unicode documentation (Unicode Consortium, 2023) and manually built lexicons being primary sources for such information. The meaning of emojis is largely socially determined, the former does not align with semantic and usage and thus lexicons are preferred. (Ahanin and Ismail, 2022a) uses a multi-label method utilising discrete classifications of 11 emotions. The work proposes a balanced weighted PMI algorithm to classify the emojis, validated against corresponding text polarity and the 11 emotion categories. This work does not consider incongruity in sentiment between the text and the emojis thus the lexicon may not be valid. Karthik, Nair and Anuradha (2018) detail the use of machine learning classifiers, artificial neural networks and convolutional neural networks to predict emoji sentiment programmatically. Poor performance (<50%

accuracy) was observed for all approaches with the exception of the convolutional neural network which yielded accuracy of 97%. Following the assessment of each model a manual assignment of polarities to emojis was utilised for the remainder of the work. The improved accuracy observed for the convolutional neural network may not necessarily be opposing the hypothesis that incongruity in sentiments may reduce the performance of such classifiers as such neural networks are ‘fully connected’ and thus overfitting occurs disproportionately compared to other models assessed in this work (Pavlitskaya, Oswald and Zöllner, 2022). The work did not discuss reasons for the poor performance of the other models; however, the methodology aligns with that of Ahanin and Ismail (2022) and thus the same logic applies. Yoo and Rayz (2021) follow a similar methodology and cited emojis with double meaning as the primary validity concern relating to their work.

This limitation was identified in all assessed works where similarity scores to text are utilised- no works could be identified which address this limitation although in some cases it was acknowledged. The consideration of figurative use-cases for emojis is likely a key limitation as many emojis are used disproportionately in a figurative manner; for example, Emojipedia found that in only 7% of cases the 🍏 emoji referred to fruit (Emojipedia, 2023). No works could be identified which discuss quantitatively the use of individual emojis in sarcastic and non-sarcastic manners, however it is known that they are used to convey figurative speech and tone regularly (Kaye, Wall and Malone, 2016).

4.5.2 Emoji Sentiment Classification – Manual Annotation

Hogenboom et al. (2013) built a lexicon utilising manual assignment of sentiment where annotators classified emojis based on a 5-point polarity scale. In the review of current methods in this work, manual assignment was the only methodology identified which avoided reliance on text comparison and was found to have high accuracy; in approximately 90% of cases all three annotators reached consensus with regards to the sentiment of the emoji and. Works in this field primarily aim to assign labels based on polarity rather than discrete emotion categories. This may be an area of opportunity as discrete emotion categories would reduce subjectivity and increase contextual clues for the text- no works evaluating this methodology could be identified during this review.

4.6 Viability of Emojis to Improve Sarcasm Detection

While computational emoji classification presents significant limitations due to the frequent use to convey figurative linguistic devices, the use of accurate corpus’ is essential to the validity of works which use emojis to gain insight into sentiment of text. Literature evaluating the topic in depth is sparse however references to future opportunities are relatively frequent. Riordan (2017) indicated that use of emojis has predictable and strategic use in text and thus patterns observed in the intent of their use may be a valid method to provide valuable context. Hand et al. (2022) evaluated the

impact on perception of text sentiment using a positive, negative, and neutral face emojis. Their work focused on the congruency of the emoji and text sentiment determining an amplification of sentiment where there was an agreement in sentiment and an increase in ambiguity where incongruency was observed. The work postulates that this may be indicative of sarcasm however did not explore a causal link. Subramanian et al. (2021) evaluated the consideration of emojis in a deep neural network for sarcasm detection and reported some improvement upon control tests however this work made use of the aforementioned poor data annotation strategy and no context awareness in the analysis of the text thus reported results do not necessarily represent the true potential of such a strategy and have validity concerns. (Prasad *et al.*, 2017) proposes a work which integrates emoji and slang dictionaries to consider their respective contributions towards sarcasm detection in tweets. The methodology is robust with regards to annotation- utilising a human-annotated dataset, however consideration towards context is omitted and the classification algorithms employed are not in line with what is presently regarded as state-of-the-art in this context. This work shows an improvement where slang and emojis are considered compared to where they are not however their respective contributions to the noted improvement are not disclosed.

4.7 Chapter Conclusion

There is a clear dichotomy between works considered evaluating emoji and text-based sentiment analysis respectively. Literature pertaining to text-based analysis highlight a lack of context as a primary limitation in cases where the tone is not evident from the words themselves but rather the subtext- where sarcasm is found. Emojis are regarded as valuable tools to enhance pragmatic understanding of text, while works aiming to consider emojis have evidence of potential, the sample sets evaluated are generally not of high quality and annotation strategies present validity concerns. The approaches with regards to sentiment analysis are not consistent across text and emoji-based work- with granularity of classifications being the primary reason for this discrepancy. In the case of text-based work, increasing granularity in emotion-based categories is the direction of development in the field- however evidence suggests that abiding by classifications outlined in basic emotion theory achieves better outcomes due to greater objectivity in groupings. In emoji-sentiment analysis the classifications are notably less granular- often operating in terms of polarity. Classifications in literature based on textual comparison do not address the impact of sarcasm on the outcomes and thus are not regarded as reliable. Valid human-annotated strategies are the present most viable present option for sentiment-labelled emoji corpus' and similar is true for annotation of sarcastic text for model training. Based on the work reviewed, emojis present great potential in this problem set and avenues for development may involve exploration of the potential of sentiment analysis classifiers for emojis and text respectively in addition contextual clues between the two. Sentiment labels have

not yet been considered in depth in this context- however many works have highlighted their potential.

The review has highlighted a key direction towards improvement upon current state-of-the-art sarcasm detection; as it has been shown to rely heavily on contextual clues, consideration of the embedded emojis within the text is a viable research avenue towards achieving improved outcomes. Current work in the field largely relies on annotation strategies which do not lend validity to reported results- future works should aim to improve upon this convention to glean results which are representative of real-world use cases of such tools.

5 Lexical Study of Emojis

This chapter aims to evaluate relevance of parameters for inclusion in an emoji lexicon with respect to the most optimal outcomes for later use to detect sarcasm. The most prevalent methodologies in literature are largely unfit for this purpose as sentiment is largely derived from adjacent text, however, incongruity in text and emoji sentiment is widely cited as a potential marker of sarcasm thus there are validity concerns with regards to any works which deploy this strategy.

5.1 Dataset Selection

5.1.1 Basic Emotional Theory

By the nature of the problem domain, there is a necessity for human-annotated data, where emojis are presented independent of any text which may influence classifications. The EmoTag1200 dataset (Awal, Shoeb and De Melo, 2020) contains information regarding volunteers' association of emojis to basic emotions, based on the Plutchik model. The presentation of emojis without any textual prompts makes this dataset uniquely suitable for this task, and methodologies for its generation are robust; multiple annotators were utilised, and agreement was monitored via Pairwise Pearson correlation and Krippendorff's α . Steps were taken to mitigate fatigue bias through randomisation and reported results represent averages of the reported values.

5.1.2 Dimensional Theory

The dataset used in this section was the Emoji Sentiment Ranking dataset (P. K. Novak *et al.*, 2015), containing rankings of the 751 most popular emojis annotated by 83 annotators as positive, negative, or neutral. Annotators were presented with the emoji alongside the text, however, were instructed to rank the emoji sentiment only. While bias associated with the textual component of the content cannot be totally ruled out in this case, no datasets presently exist which are created where emojis were annotated independent of text.

5.2 Definition of Sentiment Parameters

The following section aims to evaluate optimal approaches to define sentiment of emoji with regards to the two emotional theory models. Successful methodologies should generate parameters can fingerprint sentiment in terms of a wide array of features to facilitate highly accurate machine learning models to be constructed in subsequent work.

5.2.1 Basic Emotional Theory

The EmoTag1200 dataset contains information regarding the affinities of emoji to 8 basic emotions, which enable comparison and acknowledge that emotions are experienced synchronously with

varying strengths based on the stimulus in question. Sentiment labels c , consist of continuous values representing affinity of the emoji to each emotion within set e :

$$0 < c_e < 1$$

where $e \in \{Anger, Anticipation, Disgust, Fear, Joy, Sadness, Surprise, Trust\}$

Labels are most clearly equated to relative affinities to emotions; however, it is also reasonable to link these values to probabilities that a given emotion is the primary emotion associated with the emoji. Such a definition implies that:

$$\text{where } c_{e8} < c_{e7} < c_{e6} < c_{e5} < c_{e4} < c_{e3} < c_{e2} < c_{e1}$$

The primary basic emotion is c_{e1} , the secondary is c_{e2} and the trend continues with decreasing affinity to the emoji. The former definition aligns more literally with the intention of original authors and provides increasing granularity which may be of value when more nuanced fingerprinting between emoji is necessary. The latter yields reduced granularity however greater accuracy of models generated for prediction of unseen emoji may be possible, and thus the result may be data of overall greater value.

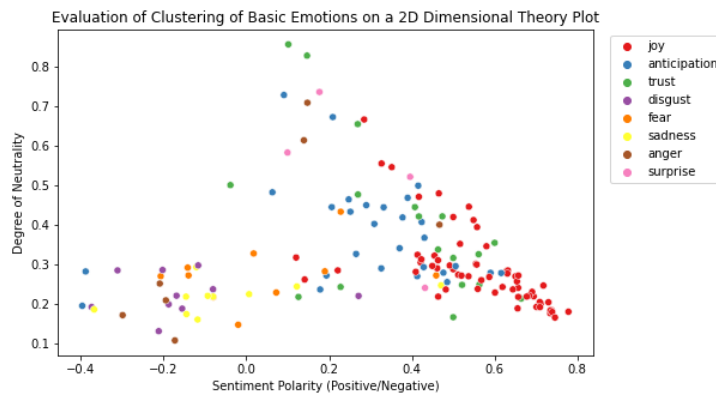

Figure 3 Cluster analysis of basic emotions on a 2D dimensional theory sentiment plot.

Evaluation of Basic Emotion Patterns in a 2D Dimensional Theory Model Plot

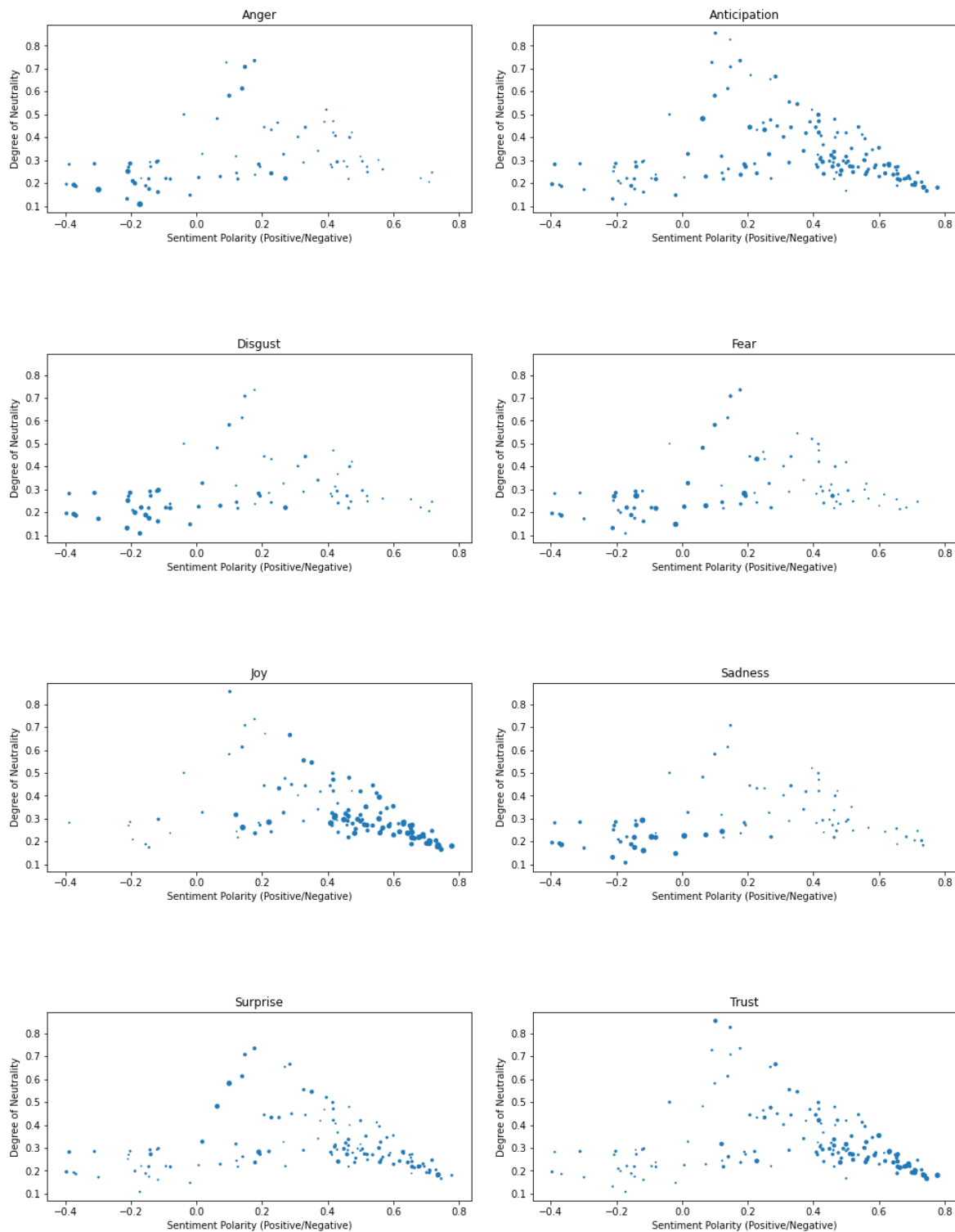

Figure 4 2D dimensional theory sentiment plots. In each case marker size is proportional to the degree of affinity of the emoji to the respective basic emotion. Joy is the basic emotion most affiliated with positive emojis, but results show trust to also be affiliated with emojis of positive sentiment. Sadness, disgust, fear and anger are linked more significantly to negative sentiment emojis – such an outcome is intuitive and provides evidence of agreement between theories in this use case. Surprise and anticipation are less inherently tied to polarity of sentiment which is additionally reflected in the visualisation. Such a result may indicate that the increased granularity of basic theory is of particular importance for identification of these emotions.

5.2.2 Dimensional Theory

The Emoji Sentiment Ranking dataset contains information regarding the frequency to which emojis are classified as positive, negative, or neutral. These classifications were represented by discrete values which consider logical ordering of categories of equal distance apart to facilitate quantitative analysis:

$$c \in \{-1, 0, 1\}$$

Using these values, a discrete probability distribution for sentiment label c , can be determined where an assumption that the sum of the three respective probability distributions is equal to one is made to normalise data across emojis which appear at varying frequencies:

$$(p_-, p_0, p_+), \sum_c p_c = 1$$

Where c is the sentiment label, and the following abbreviations were used to denote negativity, neutrality, and positivity:

$$p_- = p(-1) \text{ (Negativity)}$$

$$p_0 = p(0) \text{ (Neutrality)}$$

$$p_+ = p(1) \text{ (Positivity)}$$

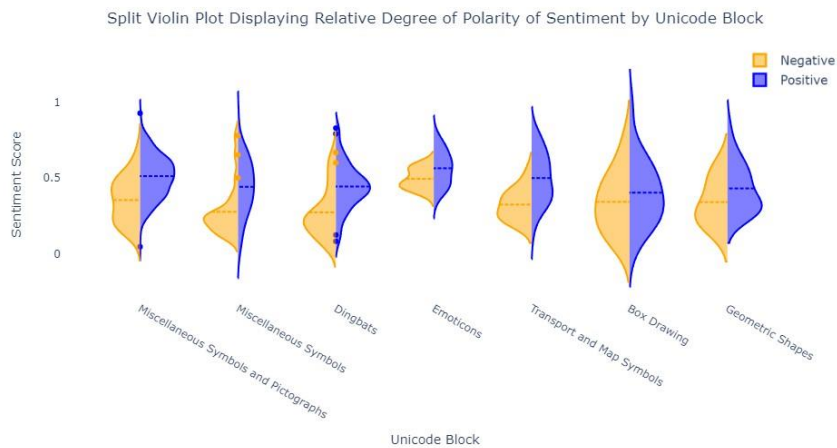

Figure 5 Distribution of polar sentiment scores across several emojis several Unicode blocks.

3D Emoji Sentiment Plot

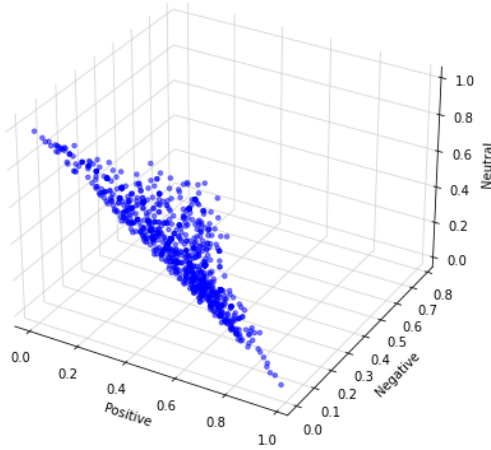

Figure 6 3D emoji sentiment score plot for all emojis in dataset.

Due to the low occurrence of annotation ($N \geq 5$ is true for the lower quartile) presented in the dataset, relative frequency is not an ideal metric for approximation of probabilistic sentiment scores in many cases as p_c will equal zero in events not observed in the data; such situations would result in bias due to the implication that certain events are impossible, whereas a low probability is more likely. For machine learning, $p_c = 0$ contributes to overfitting as data is sparser. Where non-zero probabilities are assigned to unseen events, some information about their potential occurrence is preserved and thus more robust patterns can be captured. Additionally, where N is small averages are increasingly subject to skew. Probability distributions were thus determined using a Laplace estimate:

$$p_c = \frac{N(c) + 1}{N + k}$$

Where k is the cardinality of the class, in this case $|c| = 3$. The assumption of uniform distribution for the estimator is true for the dataset in question. The smoothing model was selected for its ability to address the issue of zero-probabilities and mitigate the impacts of small N where relevant. At larger N , the output approaches p_c prior to any transformation. Such a feature of the estimator focuses its effects on cases where it is most necessary. Finally, defining \bar{s} as the mean of the probability distributions weighted against their discrete labels, a sentiment score can be determined:

$$\bar{x} = \sum_c p_c \times c$$

$$\bar{s} = (-1 \times p_-) + (0 \times p_0) + (1 \times p_+)$$

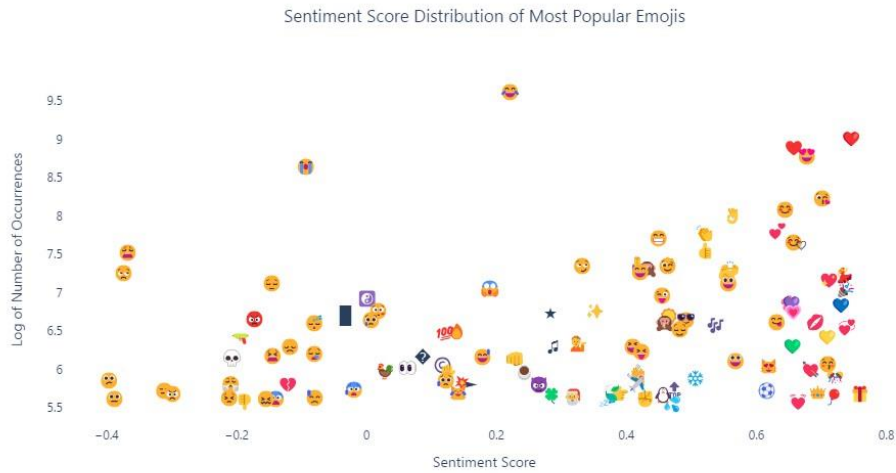

Figure 7 Sentiment Scores of 250 most popular emojis against their occurrences in the Emoji Sentiment Ranking dataset using the defined probabilistic method.

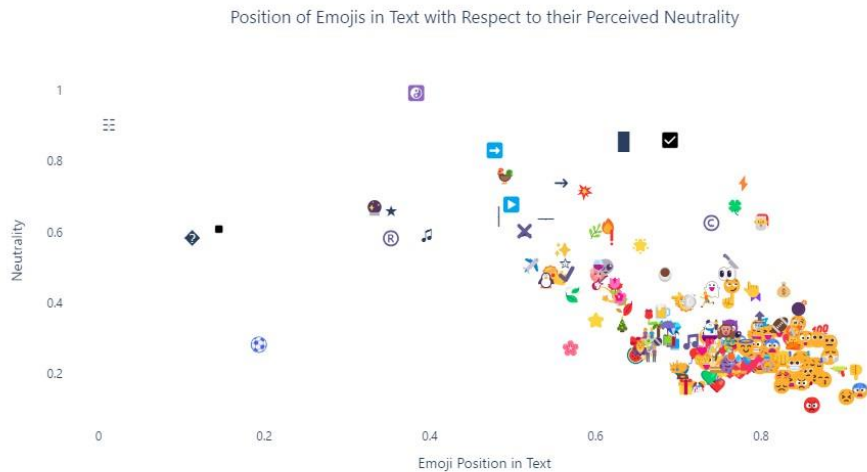

Figure 8 Degree of Neutrality (Neutral Sentiment Score) against average position of emoji in text. Emojis towards the end of text strings have lower neutrality; a greater degree of arousal per dimensional emotion theory, indicative that emojis towards the end of strings are more frequently used to convey tone or emotion compared to those appearing earlier in the string. This observation is consolidated by the frequency of face emojis, which are intuitively linked to tone and emotion with low neutrality scores at the end of sentences.

This approach aims to acknowledge the varying perceptions of emoji sentiment, dependent upon an individuals' personal usage, while retaining ability to evaluate the sentiment with regards to the consensus classification. An overall sentiment score for sentiment using discrete categorisations often employs a majority decision methodology, however in this context an alternative methodology which acknowledges a degree of subjectivity is preferable. The standard error of the mean is one such methodology which enables a more nuanced classification methodology:

$$SD = \sqrt{\sum_c p_c \times (c - \bar{x})^2}$$

$$SEM = \frac{SD}{\sqrt{N}}$$

The result of such a methodology enables the identification of a most probable classification and inclusion or exclusion of secondary potential classifications at a 95% confidence.

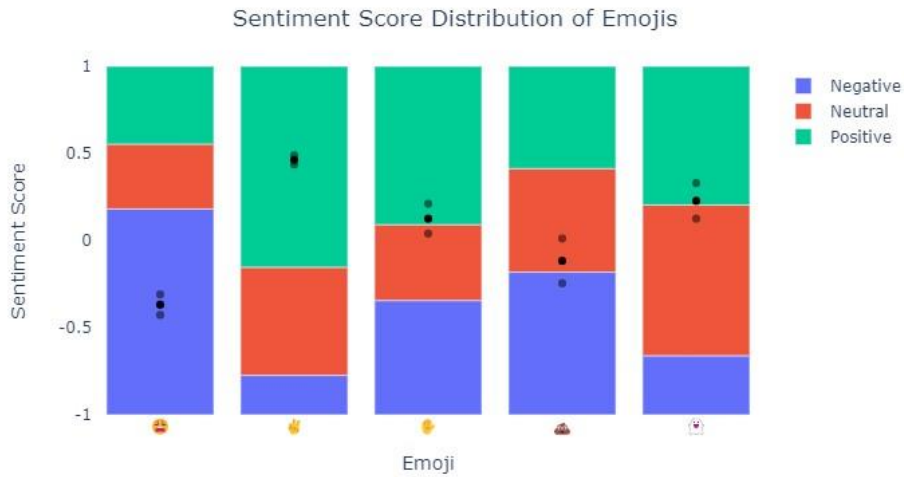

Figure 9 Sample of result of emoji sentiment classification using dimensional emotional theory. Coloured bars are proportional to p_{-} , p_0 and p_{+} . Markers (black) represent \bar{s} . Grey markers represent the limits of the 95% confidence intervals for the \bar{s} . Note weary face (left) has high confidence that a negative classifier is appropriate, however ghost (right) cannot necessarily be classified as positive with 95% confidence.

5.3 Emoji Feature Extraction

Previous works cite challenges regarding emojis lacking characteristics to enable feature extraction (Grover, 2022). The following work aims to evaluate several strategies to extract information regarding the sentiment of emoji for the purposes of improving outcomes of sarcasm detection.

5.3.1 Use of Emotion Vocabulary Embeddings

Word embeddings are representations of words as fixed-size vectors in multi-dimensional space, where each dimension captures some information about the word such as semantic and pragmatic relationships. Word2Vec is one such method to generate embeddings which has been observed to be particularly effective as capturing relationships between words (Fontaine, 2013). For example, given the male/female relationship is known:

$$King - Man + Woman = Queen$$

Relationships as above are effectively demonstrated where the results of the above transformation on the 'King' vector is very close to that of the 'Queen' vector. Given this observation, it is appropriate to use these vectors for comparative purposes, and by extension feature extraction. Emoji2Vec is an equivalent embedding which may supplement word-based corpus with emoji embeddings (Eisner et

al., 2016). Authors indicate that the vectors are intended for use alongside the Google News embedding for Twitter sentiment analysis tasks, thus this is the combination of embeddings which will be used. See section 11.1 for further discussion on the vectors selected.

Cosine similarity is a measure of similarity between two vectors, defined as follows:

$$sim(A, B) = \frac{A \times B}{\|A\| \times \|B\|} = \frac{\sum_{i=1}^N A_i \times B_i}{\sqrt{\sum_{i=1}^n A_i^2} \times \sqrt{\sum_{i=1}^n B_i^2}}$$

Where:

$$-1 < sim < 1$$

And:

$$sim = 1 \rightarrow \textit{Perfect Similarity}$$

$$sim = 0 \rightarrow \textit{Orthogonality}$$

$$sim = -1 \rightarrow \textit{Exact Opposites}$$

Which in the context of natural language processing, provides an interpretable metric appropriate for the use-case it measures directional similarity, without consideration to magnitude and is robust to high dimensionality. As word frequency influences vector magnitude, this strategy eliminates related noise while conserving semantic and pragmatic relationships between words.

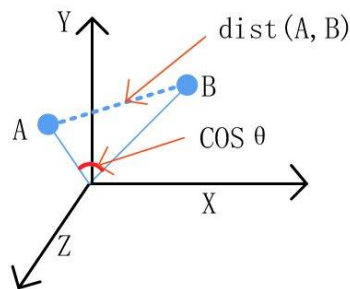

Figure 10 Cosine Similarity.

5.3.2 Word Vectors of Basic Emotion Words

This strategy aims to compare emojis (e) to each basic emotion (be) and defines emotion scores σ , based on the cosine similarity between respective vectors (v):

$$\sigma(e, be) = sim(v_e, v_{be})$$

This approach eliminates noise related to distinctions for related vocabulary however this may be too strict where the goal is correlation to human-annotated data given the varied nuance that individuals assign to emotions. To address the strict parameters bounds of this strategy, several alternatives are proposed which employ less stringent boundaries on vocabulary for comparison.

5.3.3 Binary Word Association Lexicon

This method draws upon the EmoLex lexicon (Mohammad, 2022) which assigns binary labels to convey association to basic emotions for each word. Vocabulary tagged for association with a basic emotion (V_{be}), association to the basic emotion is ranked using cosine similarity and k words (w , where $w \in$ top- k words) with greatest association are determined. Finally, the emotion score is determined as the average of resulting cosine similarities:

$$\sigma(e, be) = \frac{1}{k} \sum_w sim(v_e, v_w)$$

The method addressed the nuance related to individuals' understanding of basic emotions, however words not contained within the EmoLex vocabulary are not considered, potentially disregarding relevant vocabulary. Additionally, this model filters for inclusion based upon cosine similarity to the emoji which fails to account for the degree of association between the basic emotion and the words in the subset due to the binary nature of the labels. This likely results in negative skew in distribution of results for words uncorrelated to a given emotion.

5.3.4 Word-Emotion Intensity Lexicon

This method proposes an alternative approach which addresses the limitations associated with the use of a binary word lexicon, through the utilisation of the NRC-EIL lexicon (Mohammad, 2022) which tags vocabulary with an intensity score for affinity to a given basic emotion. This model operates on a similar principle, however, selects the top- k words based upon affinity intensity score, increasing the relevance of the considered vocabulary.

5.3.5 Results

Table 2 Pearson Correlation scores for all considered prediction methods. Bolded Scores represent the greatest correlation (positive or inverse) observed for the emotion in the respective column, excluding human agreement scores. Average values are reported with respect to absolute correlation.

Source	Variant	Anger	Anticip	Disgust	Fear	Joy	Sadness	Surprise	Trust	Average
Basic Emotion Word Similarities										
Word2Vec		0.36	-0.01	0.30	0.10	0.44	0.36	0.09	0.15	0.23
Emotion Lexicon Corpus Word Similarities										
EmoLex	k=5	0.35	-0.16	0.25	0.39	0.36	0.30	-0.04	0.14	0.25
EmoLex	k=10	0.31	-0.13	0.24	0.37	0.39	0.29	-0.09	0.15	0.25
EmoLex	k=50	0.26	-0.18	0.28	0.34	0.40	0.29	-0.02	0.15	0.24
EmoLex	k=100	0.26	-0.17	0.30	0.30	0.41	0.31	0.01	0.14	0.24
NRC-EIL	k=10	0.26	-0.16	0.13	0.20	0.30	0.32	0.05	-0.01	0.18
NRC-EIL	k=100	0.19	-0.12	0.24	0.24	0.33	0.33	-0.01	0.01	0.18
NRC-EIL	k=300	0.18	-0.13	0.23	0.25	0.31	0.33	0.02	-0.02	0.18
Human Annotation										
		0.67	0.74	0.65	0.59	0.78	0.69	0.64	0.72	0.69

Table 2 compares the mean human-annotated emotion ratings against predicted scores for the proposed methods. Direct comparison to basic emotion word vectors yielded the overall highest performance. Notably the basic emotion was the most significant factor in performance overall, with some emotions achieved varying correlation and others displayed orthogonality. The impact of context window size was varied across all subsets tested however the methodology had minimal impact on the overall results.

These results may be explainable by the nature of the relationships described by the vectors used. For example, *happiness* and *sadness* have a cosine similarity score of 0.42 using Google News Word2Vec model. This is capturing an intuitive relationship between the pair; however, within the context of this methodology, the implication that happiness is a core component of *sadness* is erroneous. This indicates that the vectors may be unsuitable for the purposes of gaining an understanding of sentiment and focus on semantics to a greater extent.

5.4 Sentiment-Aware Vector Space Modification

This section aims to modify Googles News Word2Vec Embeddings to emphasise characteristics relevant to sentiment analysis while mitigating influence of contradictory semantic relationships. Two proposed strategies which leverage word-pair polarities or correlations between basic emotions to modify vectors were evaluated. The strategies implement a stochastic gradient descent model and Adam optimiser with two possible loss functions:

$$Loss = \sum_{(w_1+w_2) \in p_s} -sim(v'_1, v'_2) + \sum_{(w_1+w_2) \in p_a} sim(v'_1, v'_2)$$

Where:

$$v'_1 = v_1 + learning\ rate \times (v_2 - v_1) \quad and \quad v'_2 = v_2 + learning\ rate \times (v_1 - v_2)$$

The goal of the above function is to maximize the similarity score of synonymous pairs of words (w_1, w_2 where $w \in p_s$), while minimizing the score for antonymous pairs (p_a) by considering their respective word vectors (v_1, v_2). Following tuning, obtaining a min value ≈ -7500 was achieved which approaches a theoretical minimum ≈ -8000 . Given the loss function which cannot account for the extent to which pairs are synonymous or antonymous, results were evaluated for models which achieved varying values of loss rather than solely the model which was capable of maximizing loss.

The alternative loss function which directly considers Pearson's correlation (r) between basic emotions for relevant datasets:

$$Loss = \sum_{\substack{(w_1+w_2) \in Vocab \\ Where P(be_1, be_2) r > 0}} (-sim(v'_1, v'_2) \times |r|) + \sum_{\substack{(w_1+w_2) \in Vocab \\ Where P(be_1, be_2) r < 0}} (sim(v'_1, v'_2) \times |r|)$$

The goal of this strategy is to optimise vector placement based upon Pearson's Correlation for all permutations (P) of Plutchik's basic emotions (be_n) using the human annotated data contained in the EmoTag1200 and NRL-EIL datasets respectively. Optimisations were weighted with respect to the correlation values to avoid shortcomings highlighted for the previous strategy and thus loss functions could be minimised rather than considering varying degrees of loss. A depth discussion of the vector optimisation models is described in section 11.2.

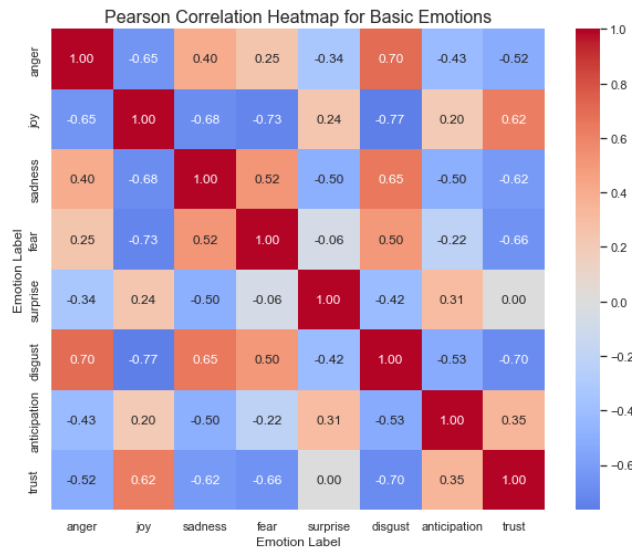

Figure 11 Pearson's correlation between basic emotion affinity scores to emojis.

5.4.1 Evaluation Parameters

The quality of outcomes was quantified by means of considering the Pearson's correlation between the approximated values for each basic emotion, using methods outlined in section 5.3 against the human-annotated values. Pearson's correlation measures the strength of association between variables:

$$r = \frac{\sum_i(x_i - \bar{x})(y_i - \bar{y})}{\sqrt{\sum_i(x_i - \bar{x})^2} \sqrt{\sum_i(y_i - \bar{y})^2}}$$

Where:

$$r = 1 \rightarrow \textit{Perfect Similarity}$$

$$r = 0 \rightarrow \textit{Orthogonality}$$

$$r = -1 \rightarrow \textit{Exact Opposites}$$

As both total similarity and opposites provide valuable information for the purposes of a regression task, the best outcome is defined as the maximum absolute value for correlation, rather than the greatest correlation.

Ideally, the approximation would yield a linear relationship to the human annotated data which would be effectively captured by Pearson's Correlation however, it is possible that more complex relationships may arise. Such relationships would provide value for regression tasks and thus are of value to identify if present. Secondary correlation coefficients were evaluated such as Spearman's Rank however no evidence was highlighted to suggest non-linear relationships were present.

5.4.2 Results

Tables 3-5 summarise the results of each iteration of vector space modification using previous estimators and drawing correlation to human-annotations for each emoji in the EmoTag1200 dataset. In the case of every basic emotion except for *anger*, modified vectors displayed improved suitability for the purpose of sentiment analysis using the Plutchik model. Results indicate the Emoji2Vec vectors were not limited by contradictory semantic relationships to the same extent as the word vectors, evident by the improved outcomes using modified word vectors alongside the original Emoji2Vec vectors. Given the disproportionate representation of emoji relative to words as a feature to convey sentiment rather than exposition or fact, this outcome is logical. The quality of outcomes across emotions seems to be related to the strength of ties between the basic emotion and sentiment polarity, consistent with observations in figure 4. For example, *joy* and *sadness* are intuitively linked to *positive* and *negative* sentiments respectively and yielded favourable results in the analysis.

Conversely *surprise* is more ambiguous to classify based on polarity and yielded lower correlation. This highlights a limitation of the proposed objective functions; they rely on the polarity of the emotions and cannot acknowledge the core feeling that they represent. While this is a relevant component of the emotions, additional emphasis on the underlying pragmatics may improve outcomes in future improvements upon the proposed models. Improved correlation was achieved which will improve outcomes for the regression model discussed in section 5.5. Results leverage the emoji vector only to obtain the outcomes, enabling the extrapolation of data to all emojis in the Emoji2Vec vocabulary. If additional parameters were considered, improved outcomes may be possible however this would limit the ability to scale to a wider population of emojis to those which the additional parameters could be sourced. As any supplementary datasets have a limited sample size, this would significantly reduce the quantity of information available relating to emoji sentiment for subsequent tasks.

Table 3 Pearson Correlation scores for all considered prediction methods following vector-space modification- method 1.

Source	Variant	Anger	Anticip	Disgust	Fear	Joy	Sadness	Surprise	Trust	Average
		Basic Emotion Word Similarities (Loss ≈-7500)								
Word2Vec		-0.01	0.10	0.04	0.13	0.21	0.10	-0.02	0.05	0.08
		Emotion Lexicon Corpus Word Similarities (Loss ≈-7500)								
EmoLex	k=5	-0.10	0.10	0.00	0.05	0.16	0.06	-0.01	-0.01	0.06
EmoLex	k=10	0.00	0.04	-0.04	0.05	0.17	0.07	-0.09	0.00	0.06
EmoLex	k=50	0.01	0.16	-0.02	0.09	0.19	0.00	-0.10	0.04	0.08
EmoLex	k=100	0.01	0.16	-0.03	0.12	0.15	0.02	-0.09	0.02	0.08
NRC-EIL	k=10	0.04	0.08	0.12	0.00	0.20	-0.01	0.03	0.02	0.06
NRC-EIL	k=100	-0.01	0.14	0.00	0.00	0.17	0.08	-0.03	0.00	0.05
NRC-EIL	k=300	0.00	0.19	-0.04	0.04	0.17	0.05	-0.05	0.01	0.07
		Basic Emotion Word Similarities (Loss ≈-5000)								
Word2Vec		0.01	0.07	-0.06	-0.04	0.04	0.10	0.00	-0.06	0.05
		Emotion Lexicon Corpus Word Similarities (Loss ≈-5000)								
EmoLex	k=5	-0.04	0.17	0.03	-0.03	0.00	0.03	0.04	-0.04	0.05
EmoLex	k=10	-0.03	0.15	0.03	-0.02	0.05	0.02	0.03	-0.02	0.04
EmoLex	k=50	-0.05	0.15	0.00	-0.03	0.02	0.01	0.02	0.03	0.04
EmoLex	k=100	-0.05	0.14	-0.01	-0.03	-0.01	0.01	0.02	0.03	0.04
NRC-EIL	k=10	-0.08	0.17	0.00	-0.04	0.05	-0.04	-0.02	0.05	0.06
NRC-EIL	k=100	-0.06	0.15	-0.01	-0.03	0.00	0.02	0.02	0.03	0.04
NRC-EIL	k=300	-0.06	0.14	-0.01	-0.04	0.01	0.02	0.03	0.05	0.05
		Basic Emotion Word Similarities (Loss ≈-3000)								
Word2Vec		0.04	-0.23	0.11	0.06	-0.25	0.12	0.04	-0.13	0.12
		Emotion Lexicon Corpus Word Similarities (Loss ≈-3000)								
EmoLex	k=5	0.07	-0.24	0.05	0.06	-0.17	0.12	0.01	-0.14	0.11
EmoLex	k=10	0.06	-0.23	0.04	0.08	-0.04	0.12	0.00	-0.15	0.09
EmoLex	k=50	0.06	-0.23	0.09	0.11	-0.12	0.14	0.03	-0.16	0.12
EmoLex	k=100	0.08	-0.22	0.12	0.14	-0.11	0.13	0.03	-0.17	0.13
NRC-EIL	k=10	0.06	-0.25	0.16	0.16	-0.10	0.07	-0.01	-0.15	0.12
NRC-EIL	k=100	0.10	-0.21	0.16	0.15	-0.16	0.10	0.03	-0.17	0.14
NRC-EIL	k=300	0.11	-0.21	0.17	0.16	-0.15	0.09	0.03	-0.18	0.14
		Basic Emotion Word Similarities (Loss ≈-1000)								
Word2Vec		0.16	0.08	0.10	0.19	0.15	0.02	0.01	0.16	0.11
		Emotion Lexicon Corpus Word Similarities (Loss ≈-1000)								
EmoLex	k=5	0.03	-0.08	0.12	0.08	0.07	0.06	0.05	-0.08	0.07
EmoLex	k=10	0.03	-0.08	0.11	0.10	0.06	0.07	0.05	-0.10	0.08
EmoLex	k=50	0.01	-0.09	0.09	0.10	0.06	0.07	0.06	-0.14	0.08
EmoLex	k=100	0.01	-0.08	0.09	0.10	0.05	0.08	0.06	-0.15	0.08
NRC-EIL	k=10	0.03	-0.09	0.04	0.10	0.06	0.08	0.06	-0.16	0.08
NRC-EIL	k=100	0.00	-0.08	0.07	0.10	0.07	0.09	0.05	-0.15	0.08
NRC-EIL	k=300	0.00	-0.08	0.08	0.09	0.06	0.08	0.05	-0.16	0.08
		Basic Emotion Word Similarities (Loss ≈-500)								
Word2Vec		0.16	0.08	0.10	0.19	0.15	0.02	0.01	0.16	0.11
		Emotion Lexicon Corpus Word Similarities (Loss ≈-500)								
EmoLex	k=5	0.06	-0.13	0.11	0.16	0.06	0.22	-0.08	-0.08	0.11
EmoLex	k=10	0.06	-0.13	0.14	0.14	0.07	0.21	-0.06	-0.11	0.12
EmoLex	k=50	0.04	-0.14	0.18	0.13	0.09	0.20	-0.02	-0.15	0.12
EmoLex	k=100	0.05	-0.15	0.17	0.12	0.08	0.19	-0.02	-0.16	0.12
NRC-EIL	k=10	0.03	-0.14	0.09	0.15	0.13	0.20	-0.01	-0.11	0.11
NRC-EIL	k=100	0.03	-0.15	0.14	0.12	0.09	0.21	-0.05	-0.16	0.12
NRC-EIL	k=300	0.04	-0.15	0.14	0.12	0.08	0.21	-0.04	-0.17	0.12
		Human Annotation								
		0.67	0.74	0.65	0.59	0.78	0.69	0.64	0.72	0.69

Table 4 Pearson Correlation scores for all considered prediction methods following vector-space modification- method 1. Original emoji vectors and transformed word vectors used.

Source	Variant	Anger	Anticip	Disgust	Fear	Joy	Sadness	Surprise	Trust	Average
Basic Emotion Word Similarities (Loss ≈-7500)										
Word2Vec		0.13	0.00	0.31	0.10	0.41	0.22	0.11	0.01	0.16
Emotion Lexicon Corpus Word Similarities (Loss ≈-7500)										
EmoLex	k=5	0.29	-0.03	0.23	0.35	0.41	0.20	-0.15	-0.14	0.23
EmoLex	k=10	0.28	-0.03	0.34	0.37	0.50	0.27	-0.11	0.04	0.24
EmoLex	k=50	0.31	-0.15	0.32	0.32	0.50	0.33	-0.07	0.20	0.28
EmoLex	k=100	0.32	-0.17	0.34	0.36	0.44	0.36	0.09	0.11	0.27
NRC-EIL	k=10	0.28	-0.18	0.32	0.29	0.35	0.29	0.20	-0.10	0.25
NRC-EIL	k=100	0.35	-0.04	0.28	0.39	0.43	0.40	-0.07	0.17	0.27
NRC-EIL	k=300	0.33	-0.03	0.30	0.42	0.48	0.44	0.03	0.20	0.28
Basic Emotion Word Similarities (Loss ≈-5000)										
Word2Vec		0.30	0.07	0.02	0.36	0.16	0.03	-0.08	-0.01	0.13
Emotion Lexicon Corpus Word Similarities (Loss ≈-5000)										
EmoLex	k=5	0.12	-0.18	0.19	0.28	0.30	0.24	-0.11	-0.09	0.19
EmoLex	k=10	0.17	-0.17	0.23	0.26	0.27	0.27	-0.07	-0.07	0.19
EmoLex	k=50	0.11	-0.17	0.21	0.17	0.20	0.24	0.00	-0.13	0.15
EmoLex	k=100	0.10	-0.18	0.21	0.15	0.20	0.21	0.04	-0.12	0.15
NRC-EIL	k=10	0.09	-0.12	0.15	0.11	0.30	0.16	0.03	-0.06	0.13
NRC-EIL	k=100	0.09	-0.14	0.18	0.16	0.24	0.20	0.02	-0.09	0.14
NRC-EIL	k=300	0.07	-0.14	0.18	0.15	0.21	0.21	0.03	-0.10	0.14
Basic Emotion Word Similarities (Loss ≈-3000)										
Word2Vec		-0.17	-0.10	-0.02	-0.11	0.04	-0.09	-0.16	-0.17	0.11
Emotion Lexicon Corpus Word Similarities (Loss ≈-3000)										
EmoLex	k=5	-0.12	-0.08	0.09	-0.03	0.11	-0.09	0.06	-0.21	0.10
EmoLex	k=10	-0.09	-0.08	0.09	-0.03	0.09	-0.06	0.04	-0.19	0.08
EmoLex	k=50	-0.10	-0.12	0.06	0.00	0.08	-0.04	0.03	-0.19	0.08
EmoLex	k=100	-0.11	-0.12	0.04	0.00	0.09	-0.03	0.04	-0.16	0.07
NRC-EIL	k=10	-0.18	-0.15	0.01	-0.02	0.19	-0.07	0.05	-0.13	0.10
NRC-EIL	k=100	-0.13	-0.13	0.05	-0.03	0.09	-0.04	0.06	-0.17	0.09
NRC-EIL	k=300	-0.11	-0.12	0.06	-0.03	0.09	-0.04	0.06	-0.17	0.09
Basic Emotion Word Similarities (Loss ≈-1000)										
Word2Vec		0.31	-0.04	0.21	0.29	0.19	0.09	-0.03	0.11	0.16
Emotion Lexicon Corpus Word Similarities (Loss ≈-1000)										
EmoLex	k=5	0.09	-0.15	0.17	0.20	0.13	0.14	-0.03	-0.20	0.14
EmoLex	k=10	0.09	-0.15	0.17	0.18	0.14	0.15	-0.02	-0.17	0.13
EmoLex	k=50	0.06	-0.17	0.17	0.12	0.14	0.15	0.01	-0.16	0.12
EmoLex	k=100	0.06	-0.16	0.18	0.11	0.14	0.15	0.03	-0.17	0.13
NRC-EIL	k=10	0.10	-0.16	0.07	0.08	0.17	0.16	0.04	-0.13	0.11
NRC-EIL	k=100	0.04	-0.15	0.15	0.12	0.16	0.16	0.02	-0.15	0.12
NRC-EIL	k=300	0.04	-0.15	0.15	0.11	0.15	0.15	0.02	-0.16	0.12
Basic Emotion Word Similarities (Loss ≈-500)										
Word2Vec		0.30	0.03	0.28	0.28	0.39	0.11	0.05	0.22	0.21
Emotion Lexicon Corpus Word Similarities (Loss ≈-500)										
EmoLex	k=5	0.09	-0.20	0.18	0.24	0.19	0.19	-0.08	-0.16	0.17
EmoLex	k=10	0.11	-0.19	0.25	0.21	0.18	0.22	-0.06	-0.14	0.17
EmoLex	k=50	0.08	-0.18	0.22	0.16	0.17	0.19	0.00	-0.13	0.14
EmoLex	k=100	0.08	-0.17	0.23	0.14	0.17	0.19	0.02	-0.14	0.14
NRC-EIL	k=10	0.06	-0.16	0.10	0.18	0.25	0.21	0.04	-0.08	0.14
NRC-EIL	k=100	0.07	-0.15	0.17	0.14	0.21	0.21	0.00	-0.11	0.13
NRC-EIL	k=300	0.07	-0.15	0.16	0.14	0.18	0.21	0.02	-0.13	0.13
Human Annotation										
		0.67	0.74	0.65	0.59	0.78	0.69	0.64	0.72	0.69

Table 5 Pearson Correlation scores for all considered prediction methods following vector-space modification- method 2.

Source	Variant	Anger	Anticip	Disgust	Fear	Joy	Sadness	Surprise	Trust	Average
Basic Emotion Word Similarities (Both Modified Vectors)										
Word2Vec		0.19	-0.13	0.21	0.16	0.20	0.11	-0.08	-0.12	0.15
Emotion Lexicon Corpus Word Similarities (Both Modified Vectors)										
EmoLex	k=5	0.10	-0.13	0.08	0.19	0.16	0.14	-0.07	-0.07	0.12
EmoLex	k=10	0.09	-0.11	0.10	0.16	0.16	0.16	0.02	-0.04	0.11
EmoLex	k=50	0.06	-0.12	0.11	0.10	0.17	0.13	0.02	-0.03	0.09
EmoLex	k=100	0.06	0.11	0.10	0.09	0.16	0.13	0.03	-0.04	0.09
NRC-EIL	k=10	0.01	-0.09	0.07	0.05	0.21	0.09	-0.02	0.00	0.07
NRC-EIL	k=100	0.02	-0.07	0.11	0.08	0.16	0.11	0.01	0.02	0.07
NRC-EIL	k=300	0.01	-0.08	0.09	0.08	0.15	0.12	0.03	0.00	0.07
Basic Emotion Word Similarities (Modified Word Vectors Only)										
Word2Vec		0.36	-0.11	0.38	0.41	0.44	0.18	-0.11	-0.24	0.28
Emotion Lexicon Corpus Word Similarities (Modified Word Vectors Only)										
EmoLex	k=5	0.24	-0.17	0.18	0.42	0.34	0.26	-0.16	-0.11	0.24
EmoLex	k=10	0.22	-0.16	0.25	0.33	0.30	0.28	-0.06	-0.05	0.21
EmoLex	k=50	0.19	-0.20	0.27	0.25	0.31	0.27	-0.02	-0.09	0.20
EmoLex	k=100	0.20	-0.19	0.29	0.24	0.30	0.28	0.00	-0.12	0.20
NRC-EIL	k=10	0.12	-0.14	0.14	0.23	0.40	0.16	-0.04	-0.04	0.16
NRC-EIL	k=100	0.14	-0.11	0.22	0.22	0.31	0.27	-0.01	-0.06	0.17
NRC-EIL	k=300	0.15	-0.13	0.21	0.22	0.27	0.29	0.03	-0.08	0.17
Human Annotation										
		0.67	0.74	0.65	0.59	0.78	0.69	0.64	0.72	0.69

5.5 Emoji Sentiment Prediction – Basic Theory

The following section details the process and results for a regression task of sentiment data with regards to basic emotional theory. The purpose of this work is to use previously extracted features to make predictions of emoji affinity to basic emotions for those which are unavailable from the EmoTag1200 dataset. This information will serve to introduce sentiment information regarding emojis into later sarcasm detection models.

5.5.1 Data Preparation

Prior to the implementation of any models, preparation and evaluation of the data is essential to make an informed decision with regards to the model selected for the task in addition to optimising model performance. Data preparation and an assessment of the features of the task for this purpose have been detailed in section 11.4.

5.5.2 Model Selection

Model selection was carried out using the following approach:

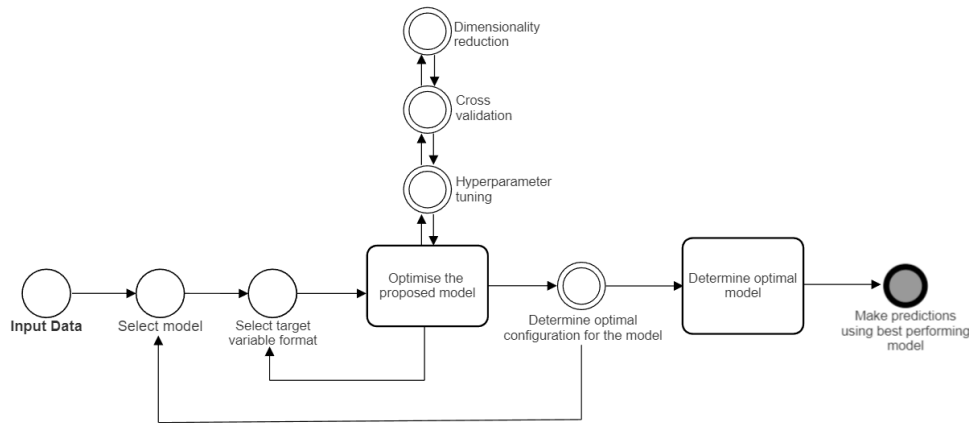

Figure 12 Process to select model for basic theory regression task.

The goal of the approach was to evaluate each considered model in its most robust, optimised configuration to ensure the most accurate model could be identified. Each step in this process is discussed in section 11.4.

5.5.3 Model Evaluation

Table 6 reports the results of model evaluation for each basic emotion. The goal was to identify the model which yielded an outcome which minimised mean absolute error and mean squared error, while maximising R^2 score. Where the optimal metrics for a basic emotion were distributed across multiple models the determination of the optimal model considered relative trade-offs between the metrics in each case. For example, where a model had a slightly lower mean absolute error than its alternative, but a much higher R^2 score, a cost-benefit analysis would favour this model. Metrics for training, validation and test were all considered in the context of one another, where close alignment was viewed with preference, as this signals good generalisation.

As the degree of affinity to each basic emotion exists on differing scales, it is important to consider their respective ranges and mean values when considering the reported absolute performance metrics. Table 7 uses mean values to provide an indication of the accuracy of the models. While this cannot consider the distribution of error across the set, this can be inferred from the mean squared error values.

Identified optimal models for each emotion generally had moderate ability to explain the underlying patterns in the training data, evidence by their respective R^2 scores. However, this was not the case for *anticipation* and *surprise*, which had poor performance. This consolidates previous hypothesis relating to the limitations of the proposed objective functions to modify the word vectors as these emotions are distinct from the others in that they can apply in both positive and negative contexts and are distinguished by additional features.

Accuracy scores averaging 90% were achieved for the basic emotion regression (86% < model accuracy < 92%). A potential limitation of the performance was the limited data for training. An expansion of the annotated data may improve the outcomes of these models or enable the use of models capable of capturing more complex patterns in future works. Supplementary features gleaned from other sources may have improved outcomes for this task, however the use of word vectors only for feature extraction makes expansion upon this dataset more accessible as the emoji corpus expands, which is a primary strength of this approach.

Table 6 Results of model development process for basic theory regression displaying the best outcomes for each model, correct to three significant figures. The selected optimal model is in bold for each basic emotion. Note that reported metrics are with reference to validation performance.

Model	Performance Metric		
	Mean Absolute Error	Mean Squared Error	R ² Score
Anger			
Linear Regression	0.0112	0.000230	0.148
Random Forest	0.0136	0.000290	-1.41
XGBoost Regression	0.0127	0.000283	-1.35
Support Vector Regression	0.0318	0.00112	-2.63
Gaussian Process Regression	0.00915	0.000171	0.365
KNN Regression	0.0110	0.000292	-0.0858
Anticipation			
Linear Regression	0.0118	0.000217	-0.238
Random Forest	0.0122	0.000201	-0.143
XGBoost Regression	0.0142	0.000251	-0.432
Support Vector Regression	0.0136	0.000241	-0.373
Gaussian Process Regression	0.0117	0.000185	-0.0557
KNN Regression	0.0114	0.000189	-0.0735
Disgust			
Linear Regression	0.0121	0.000270	0.310
Random Forest	0.0145	0.000419	-0.0697
XGBoost Regression	0.0147	0.000456	-0.164
Support Vector Regression	0.0206	0.000543	-0.385
Gaussian Process Regression	0.0126	0.000273	0.303
KNN Regression	0.0159	0.000419	-0.0691
Fear			
Linear Regression	0.0119	0.000319	0.0607
Random Forest	0.0162	0.000351	0.0578
XGBoost Regression	0.0183	0.000477	-0.282
Support Vector Regression	0.0263	0.000840	-1.25
Gaussian Process Regression	0.0113	0.000170	0.543
KNN Regression	0.0158	0.000397	-0.0670
Joy			
Linear Regression	0.0236	0.00114	-0.0148
Random Forest	0.0313	0.00147	-0.312
XGBoost Regression	0.0350	0.00186	-0.663

Model	Performance Metric		
	Mean Absolute Error	Mean Squared Error	R ² Score
Joy (cont.)			
Support Vector Regression	0.0295	0.00115	-0.0254
Gaussian Process Regression	0.0199	0.000614	0.451
KNN Regression	0.0287	0.00113	-0.00802
Sadness			
Linear Regression	0.0152	0.000381	0.417
Random Forest	0.0166	0.000669	-0.0241
XGBoost Regression	0.0159	0.000462	0.292
Support Vector Regression	0.0303	0.00106	-0.619
Gaussian Process Regression	0.0144	0.000408	0.375
KNN Regression	0.0189	0.000721	-0.104
Surprise			
Linear Regression	0.0103	0.000156	-0.0299
Random Forest	0.0106	0.000178	-0.0484
XGBoost Regression	0.0131	0.000246	-1.05
Support Vector Regression	0.0141	0.000270	-1.25
Gaussian Process Regression	0.00973	0.000141	-0.173
KNN Regression	0.0111	0.000199	-0.659
Trust			
Linear Regression	0.0128	0.000303	0.202
Random Forest	0.0169	0.000495	-0.300
XGBoost Regression	0.0173	0.000530	-0.393
Support Vector Regression	0.0176	0.000410	-0.0776
Gaussian Process Regression	0.153	0.000519	-0.411
KNN Regression	0.0171	0.000484	-0.272

Table 7 Assessment of model accuracy considering the mean values of each basic emotion.

Basic Emotion	Mean Value for Affinity to Emoji	Mean Absolute Error	% Accuracy Approximation
Anger	0.122	0.00915	92.50
Anticipation	0.137	0.0114	91.68
Disgust	0.102	0.0121	88.14
Fear	0.120	0.0113	90.58
Joy	0.138	0.0199	85.58
Sadness	0.118	0.0152	87.12
Surprise	0.122	0.0103	92.20
Trust	0.131	0.0128	90.23

5.6 Emoji Sentiment Prediction – Dimensional Theory

The nature of dimensional theory-based sentiment metrics does not facilitate solutions similar to that which was implemented for basic theory parameters as word vectors associated with *positive* and *negative* vocabulary would necessitate the consideration of context and topic to a much greater

extent making this a more complex problem set. No human-annotated datasets were identified which provide equivalent data to the EmoLex of NRL-EIC lexicons thus the proposed adaptation of the previous methodology (a) compared emoji vectors directly to the vectors of the respective labels, and (b) compared label vectors to the vocabulary of the iSarcasm dataset. Such vocabulary was selected as it represents the vernacular of the population which may use sarcasm in online content thus the words highly associated with the emojis based on their vectors were likely to be relevant choices.

Results obtained using both options performed poorly with respect to generating predictions which correlated to the human-annotated data, and consequently was not useful in predicting information for emojis unseen in the dataset. This approach was unable to obtain accuracies >50% and thus alternative strategies were explored.

Given the limitations in data quantities available to train vectors and the subsequent regression models, pre-trained models were postulated to generate improved outcomes as they benefit from increased volume of training data and computational power available during their training process. Such factors yield a model capable of capturing more complex relationships thus results which mirror human annotations more closely. Several pre-trained models were assessed with regards to their abilities to predict dimensional theory data which correlated to human annotations assessed via Pearson's correlation. Models selected for assessment based on suitability of architecture and use in similar problem sets within literature (detailed in section 11.5).

5.6.1 Results and Methodology Evaluation

The optimal model identified was the latest Twitter RoBERTa Base Sentiment (Barbieri *et al.*, 2020) which achieved a Pearson's correlation of 0.83 to the human annotated sentiment scores. Fine-tuning the model using the human-annotated data did not result in improvement to this score, likely due to the small quantity of data available for the purpose therefore the model was deployed for the regression task without optimisation.

While the results obtained yielded good correlation to the human annotated data, the input of a single emoji in each case to obtain the results does not necessarily align with the intended use for the model; the attention mechanisms cannot provide contextual information from surrounding information and thus outputs may be limited to some degree by ambiguity. Alternative methodologies would likely involve the input of emoji-containing strings of text, however in the context of the problem set this also has limitations; the sentiment may be skewed by the content of the text. This concept also applies to some extent even where the emoji is inputted in isolation due to the training data. While the approach has limitations, the solution would involve the obtaining of a larger training dataset with

annotations. Such a task is outside the scope of this work however may be an avenue for future consideration.

5.7 Chapter Conclusion

The aim of this chapter was to establish viable methods for feature extraction of emojis, with focus on extraction of sentiment markers. Intuitive and interpretable definitions for quantitative sentiment features were proposed which enabled the comparison of human-annotated labels to predictions generated during feature extraction. Previous literature highlighted limitations in feature extraction as a primary constraint upon the use of emoji for natural language processing tasks. Sentiment focused feature extraction was performed solely using emoji vectors, ensuring the strategy can be implemented for any emojis which are released in the future. The vectors were additionally trained on information from the Unicode Consortium, which is released alongside every new emoji further facilitating scalability. These vectors were modified to improve their sentiment awareness which achieved improved outcomes in the proposed pipeline for prediction of basic emotion sentiment metrics. Areas for future improvements largely surround the limited training data which limited the complexity of models viable for use and thus the complexity of patterns which could be learned. The objective functions proposed during vector space modification may be improved by adding to the information they capture; strategies which consider sentiment in a more nuanced manner have potential to improve outcomes of this work. The work carried out in this chapter has established sentiment-based feature parameters for approximately 1660 emojis available presently from the Unicode Consortium, significantly expanding upon the data available from human-annotated datasets available presently with comparable data. The pipeline is viable for future expansions upon this work as it does not rely on any parameters external to the vectors for the emoji.

6 Pragmatics of Sarcasm

The literature review conducted highlighted validity concerns with regards to annotation and sampling. Sarcastic tweets were primarily sourced across the surveyed literature through identification of key hashtags such as '#sarcasm'. This strategy was shown to result in an unrepresentative sample of sarcastic tweets (Davidov, Tsur and Rappoport, 2010). This is likely to reduce performance on sarcasm detection models on more organic instances and thus true performance of such models is difficult to assess. One study found that only 15% of tweets labelled as sarcastic using this methodology were true labels- demonstrating the significant shortcomings to this strategy (Bamman and Smith, 2015).

Datasets with a more robust sampling methodology exist, however there is little data available in these datasets which contain emojis. The iSarcasm dataset collected self-reported sarcastic and non-sarcastic tweets from participants, alongside a rephrase of the tweet in a more literal style to improve upon the current convention. The work was subject to quality control by a linguistics professional therefore it is likely that the results are more representative of organic sarcastic content than the previously discussed sampling strategy.

This chapter aims to expand upon the presently limited datasets which represent organic occurrences of sarcasm on Twitter. This will be achieved through the following steps:

- Distribution of a survey to obtain a greater pool of annotated data containing emojis.
- Quantitative evaluation of the survey results against the identified gold-standard annotation strategy.
- No works could be identified which provided a quantitative assessment of the impacts of poor data collection practices. A sample of 5 prominent datasets implementing iterations of the strategy will be evaluated.

6.1 Primary Research Methodology

This primary research aims to adapt the iSarcasm dataset to evaluate emoji use patterns in sarcastic and non-sarcastic tweets. The adaptation will consist of the addition of emojis to known sarcastic and non-sarcastic text by survey participants. The methodology collects quantitative data regarding demographics of the sampled population in addition to quantitative data regarding emoji use in sarcastic and control content. The components of the survey including sampling strategies, question selection and format and design optimisation are discussed in section 11.6.

The goal of this work is to generate a dataset of verified sarcastic and control data which is richer in emojis. There are some limitations to this strategy; these are tweets where the author did not

originally use emojis. While the use of emojis is known to be systematic in nature, it is a reasonable assumption that two people could create a tweet with matching sentiment and pragmatic intent, where one uses emojis and the other does not. A more optimal approach would ask participants to self-report a sample of their tweets containing emojis as sarcastic and non-sarcastic to generate a dataset rather than providing prompts due to the possibility of irrelevant text to the participant reducing the quantity of usable results. The issue of relevance is addressed by enabling participants to not assign classifications to text which is not relevant or understood by them. If efforts were made to use information about the participants to provide prompts of relevance to them, there would be significant potential for bias and thus the possibility of random sampling of prompts yielding irrelevant prompts in some cases is acceptable.

Use of the same strategy as that of the iSarcasm dataset is not practical in the context of the timelines of this work as response rate would likely be impacted significantly by the additional effort required by participants. Sufficient response volume is important to ensure the results are reasonable to attribute to the population as a whole and thus the proposed method is the best option in this case. Raw results for the survey can be found in section 11.12.

6.2 Survey Outcomes

6.2.1 Demographics

The survey yielded 87 responses which can be deconstructed as follows:

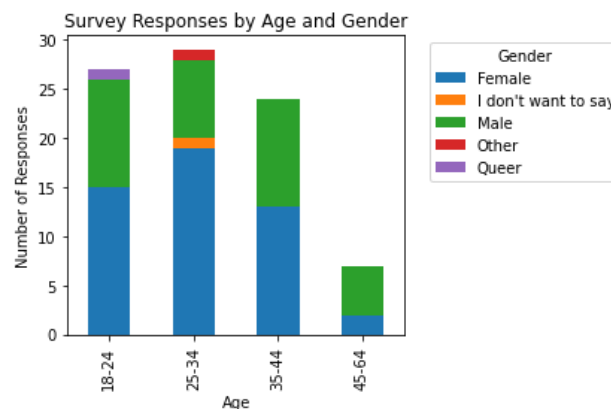

Figure 13 Survey responses deconstructed by demographics.

Responses were not distributed evenly across subsets of the population, skewing towards females and younger individuals. The shape of the age-related data is expected given that social media and emojis are used disproportionately by younger people. No participants were identified for over 65 years of age, which is likely attributable to the demographics of social media and emoji users. The age

distribution of the survey aligns well with the distribution of Twitter users, a result which may be more desirable than even distribution in this context (Dixon, 2023).

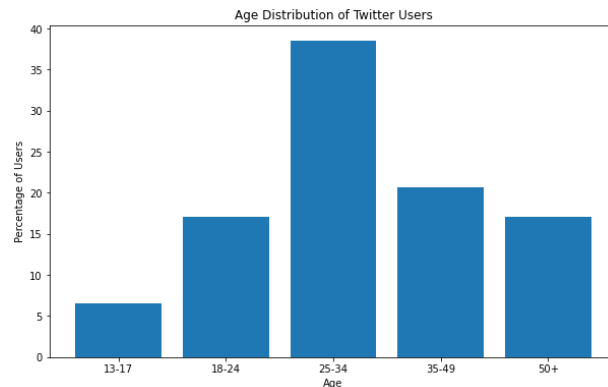

Figure 14 Age distribution of Twitter users.

Survey results with regards to gender were not closely aligned to Twitters user-base. In English speaking countries, the proportion of female Twitter users is approximately 42%, a lesser proportion than the survey outcome where females make up 58% of the respondents. Given the contradictory skew in gender representation, further evaluation must be carried out to identify any differences in behaviours which correlate to gender.

6.2.2 Annotations

Given the 1:1 split of speculative labels for each survey, the distribution of sarcastic and non-sarcastic assignments is an encouraging indication for the quality of the outcome. It indicates that although participants were explicitly informed of the surveys focus on their assessment of sarcasm within the text prompts, this does not appear to have impacted the classifications. This point addresses a consideration with regards to survey validity; the comprehension of the underlying nature of a study could conceivably introduce variance to the subjects' responses. Hence, the potential for such an influence warrants consideration in the evaluation of the implications of any conclusions drawn.

The assignment of annotations is seen to be independent of gender in figure 15. Such an observation addresses previously highlighted concerns regarding the demographics of respondents.

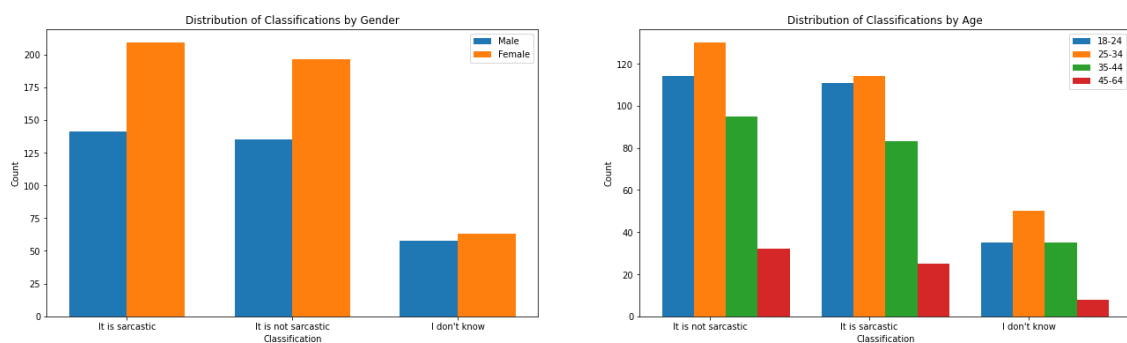

Figure 15 Classification results breakdown by gender These parameters were found to have minimal impact on the rates of sarcasm reported in responses.

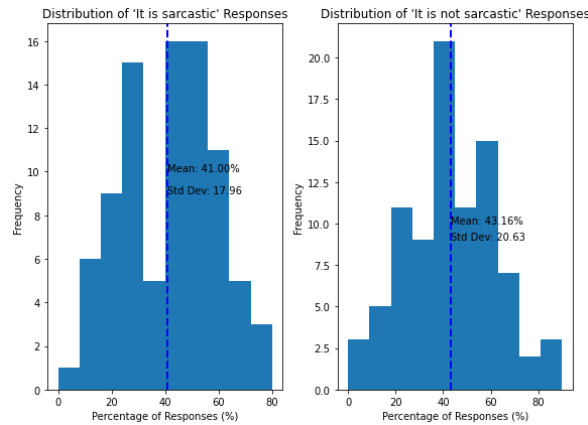

Figure 16 Distribution of labels assignments for each survey response. Where 'I don't know' was selected 15.84% of the time (approximately 1-2 times per survey). Considering only sarcastic and non-sarcastic labels and controlling for unassigned text 68% of respondents answered within 2 responses of a 1:1 ratio, aligning closely with speculative labels.

Inter-annotator patterns may be evaluated through the consideration of the quality control questions. Where text prompt is controlled, comparative work between participants is more intuitive. Agreement was not achieved in many cases, which is expected where context or the individuals' personal beliefs are of greater relevance to the perception of the text prompt. Consider the following prompt where the beliefs of the participant were likely to have an impact on their response:

Vaccine dose 1. Thank you, science.

Responses labelled sarcastic:

Vaccine dose 1. Thank you, science. 🤖

Vaccine dose 1. Thank you, science. 😏

Responses labelled non-sarcastic:

Vaccine dose 1. Thank you, science. 👍

Vaccine dose 1. Thank you, science. 👍

Vaccine dose 1. Thank you, science. ❤️

However, in cases where the text prompt does not represent content that has ties to personal beliefs agreement between annotators was high:

Text prompt:

was not aware that Crocs were appropriate business casual attire.

Responses were universally labelled sarcastic:

was not aware that Crocs were appropriate business casual attire.

was not aware that Crocs were appropriate business casual attire. 😏

was not aware that Crocs were appropriate business casual attire. 😏

was not aware that Crocs were appropriate business casual attire. 😏

was not aware that Crocs were appropriate business casual attire. 😏

was not aware that Crocs were appropriate business casual attire. 😏

was not aware that Crocs were appropriate business casual attire. 😏

Such an observation indicates that successful sarcasm detection models may benefit from the implementation of sophisticated models which can weigh the degree to which topics are tied to beliefs which are polarised across the population. This adds additional complexity to the necessary context awareness, making this a challenging problem set to overcome.

6.3 Statistical Analysis of Pragmatics in Sarcastic Content

6.3.1 Structural and Sentiment Features

The following work aims to establish which structural, or sentiment parameters have statistical significance when identifying sarcasm in short form text prompts. Section 11.7 discusses the selection methodology for statistical tests selected in each case. Results indicate that emojis were more frequently added to tweets considered to be sarcastic by the annotator, indicating that consideration of emojis is of particular benefit for sarcasm detection in the NLP domain. The emojis in sarcastic and non-sarcastic content overlap, however the context which they are used displayed incongruence. Sarcastic content evaluated largely used emojis with literal implications of positive affect alongside negative events conveyed in the text. This result consolidates observations throughout literature that emojis are used to highlight tone or sentiment, where the intended sentiment is incongruent with the literal.

Table 8 Top 10 Most Used Emojis in Survey Results.

Sarcastic Tweets		Non-Sarcastic Tweets	
Emoji	Occurrences	Emoji	Occurrences
	42		17
	19		17
	18		13
	17		12
	13		11
	13		10
	10		9
	10		8
	10		7
	9		6

Sarcastic tweets containing emoji:

Love living in a capitalist society where I look forward to getting a surgery where I'm legit GETTING AN INTERNAL BODY PART REMOVED bc it means I'll get a few days off from work xoxo

The only thing I got from college is a caffeine addiction

"2 things I love: 1. Being woken up by construction work an hour before my alarm. 2. Sarcasm."

Gonna go cry now some no face told me to lose weight x

Non-Sarcastic tweets containing emoji:

I never thought I'd say this, but I have become one of those people who like bounty bars.

Quarantine Day 256: Dear Ancient Greeks, re: the blanket-wearing I get it. #QuarantineLife

@sadgirlkali Make your husband agree to let you die first. FUN date topic for discussion

"If I could have changed anything about my childhood, I would have never watched SpongeBob -no one"

Evaluation of sentiment, structural or grammatical parameters relating directly to emojis and the text prompt itself was carried out to determine parameters which may be of importance for sarcasm

detection. Such parameters were defined as any parameters which had a statistically significant difference between sarcastic and non-sarcastic subsets within the survey results.

The emojis in sarcastic content were found to have greater neutrality than those in the non-sarcastic subset, and use of positive sentiment emojis greater. These results indicate that emojis may serve to subdue the perceived sentiment of sarcastic text; a reasonable modality since sarcasm is employed in the delivery of unfavourable messages. For the purposes of sarcasm detection, this confirms hypothesis regarding the importance of sentiment incongruity.

Structural markers were additionally evaluated. Interjections were found to occur at greater frequencies in sarcastic content, user mentions were found to be more frequent in non-sarcastic content. Use of capitalisation was found to differ with mid-word capitalisation and capitalised words occurring more frequently in non-sarcastic content. These observations lend support to evidence that users who generate sarcastic content do so with a more colloquial idiom, with less regard for legibility of the content; by extension the rigidity of conformance to punctuation and grammar may be an additional parameter for exploration.

Initial evaluation assessed features across the ensure sample set. However, observations from this work indicated that this methodology may be limited by potential destructive interference between positive and negative content, which was determined to have differing presentations of sarcasm. To evaluate this further, secondary evaluation was carried out, using positive and negative subsets.

More features of significance were identified using this approach, consolidating postulations of varied presentation of sarcasm with polarity and highlighting the importance of consideration towards sentiment in sarcasm detection. Results discussed are detailed in tables 9-12.

Table 9 Statistical Evaluation of Emoji-Based Markers of Sarcasm.

Sarcastic Content			Non-Sarcastic Content			Significant difference between Sarcastic and Non-Sarcastic Content		
Overall	Positive Subset	Negative Subset	Overall	Positive Subset	Negative Subset	Overall	Positive Subset	Negative Subset
Frequency of Emoji Use								
0.980	0.979	0.980	0.607	0.602	0.611	Yes	Yes	Yes
Position of Emojis in Text								
0.947	0.943	0.954	0.972	0.961	0.980	No	No	No
Sentiment Score of Emojis Used								
0.101	0.312	-0.0430	0.130	0.496	-0.181	No	Yes	Yes
Degree of Positivity of Emojis Used								
0.337	0.453	0.258	0.372	0.572	0.203	No	Yes	Yes
Table 9 continued on the next page.								

Sarcastic Content			Non-Sarcastic Content			Significant difference between Sarcastic and Non-Sarcastic Content		
Overall	Positive Subset	Negative Subset	Overall	Positive Subset	Negative Subset	Overall	Positive Subset	Negative Subset
Degree of Negativity of Emojis Used								
0.236	0.141	0.301	0.243	0.0754	0.384	No	Yes	Yes
Degree of Neutrality of Emojis Used								
0.406	0.406	0.353	0.385	0.353	0.413	Yes	Yes	Yes
Degree of Anger Expressed through Emoji								
0.0699	0.0709	0.0692	0.0711	0.0713	0.0709	No	No	No
Degree of Anticipation Expressed through Emoji								
0.0788	0.0801	0.0779	0.0802	0.0799	0.0804	No	No	No
Degree of Disgust Expressed through Emoji								
0.0582	0.0596	0.0573	0.0593	0.0595	0.0591	No	No	No
Degree of Fear Expressed through Emoji								
0.0689	0.0699	0.0681	0.0696	0.0690	0.0701	No	No	No
Degree of Joy Expressed through Emoji								
0.0810	0.0826	0.0709	0.0816	0.0809	0.0822	No	No	No
Degree of Sadness Expressed through Emoji								
0.0687	0.0689	0.0686	0.0693	0.0675	0.0708	No	No	No
Degree of Surprise Expressed through Emoji								
0.0708	0.0720	0.0699	0.0718	0.0712	0.0723	No	No	No
Degree of Trust Expressed through Emoji								
0.0809	0.0826	0.0798	0.0822	0.0820	0.0823	No	No	No

Table 10 Statistical Evaluation of Emoji-Based Sentiment Skew in Tweets.

Parameter 1	Parameter 2	Skew Observed
Positive/Negative Sentiment in Sarcastic Tweets		
0.337	0.236	Yes
Positive/Negative Sentiment in Non-Sarcastic Tweets		
0.372	0.242	Yes

Table 11 Statistical Evaluation of Sentiment Congruence Between Emojis and Text.

Sarcastic Content			Non-Sarcastic Content			Significant difference between Sarcastic and Non-Sarcastic Content		
Overall	Positive Subset	Negative Subset	Overall	Positive Subset	Negative Subset	Overall	Positive Subset	Negative Subset
Average Text-Emoji Sentiment Incongruence – Positivity Score								
0.278	0.355	0.225	0.271	0.362	0.191	No	No	Yes
Average Text-Emoji Sentiment Incongruence – Negativity Score								
0.266	0.169	0.334	0.241	0.150	0.321	No	No	No
Average Text-Emoji Sentiment Incongruence – Neutrality Score								
0.197	0.224	0.179	0.236	0.280	0.198	Yes	Yes	Yes

Table 12 Statistical Evaluation of Text-Based Markers of Sarcasm.

Sarcastic Content			Non-Sarcastic Content			Significant difference between Sarcastic and Non-Sarcastic Content		
Overall	Positive Subset	Negative Subset	Overall	Positive Subset	Negative Subset	Overall	Positive Subset	Negative Subset
Average Text Sentiment Score								
-0.0324	0.594	-0.451	0.0184	0.687	-0.557	No	Yes	Yes
Average Text Positivity Score								
0.319	0.654	0.0933	0.361	0.712	0.0584	No	Yes	Yes
Average Text Neutrality Score								
0.330	0.286	0.362	0.297	0.262	0.326	Yes	No	No
Average Text Negativity Score								
0.351	0.0600	0.544	0.342	0.0249	0.615	No	Yes	Yes
Average Tweet Length								
19.0	18.7	19.2	18.5	17.0	19.8	No	No	No
Average Number of Hashtags								
0.104	0.164	0.0634	0.148	0.235	0.0725	No	Yes	No
Average Number of Laughter Indicators								
0.0232	0.0357	0.0146	0.00836	0.00602	0.0104	No	Yes	No
Average Number of Capitalised Words								
1.89	1.79	1.97	2.31	2.46	2.17	Yes	Yes	Yes
Average Number of User Mentions								
0.168	0.157	0.176	0.343	0.464	0.238	Yes	Yes	Yes
Average Instances of Pragmatically Relevant Punctuation								
0.406	0.371	0.429	0.460	0.211	0.674	No	Yes	Yes
Average Instances of Affirmatives								
0.574	0.650	0.522	0.549	0.440	0.642	No	Yes	Yes
Average Instances of Negations								
0.516	0.329	0.644	0.518	0.247	0.751	No	Yes	Yes
Average Instances of Intensifiers								
0.423	0.329	0.488	0.354	0.343	0.363	No	No	Yes
Average Instances of Interjections								
1.55	1.37	1.67	0.864	0.717	0.990	Yes	Yes	Yes
Average Instances of Mid-Word Capitalisation								
0.490	0.493	0.488	0.816	1.04	0.621	Yes	Yes	Yes

6.3.2 Context-Based Features

Given the consensus across literature of the importance of context in identification of sarcastic content, evaluation of topics is of importance to this work. Topic modelling was carried out to identify relevant topics for the overall dataset, compared to the sarcastic subset. The topic modelling process is documented in section 11.9.

Table 13 Topics Identified for Sarcastic and Non-Sarcastic data using topic modelling.

Overall Dataset Topic Interpretation	Sarcastic Subset Topic Interpretation
Expression of Preference	Leisure Activities
Reflection or Contemplation of Past Events	Opinions of Others (In the Media)
Personal Experiences OR Expectations	Appearance and Clothing
Routine Life	Opinions and Thoughts

The topics gleaned from the respective training sets display distinctions, where those relating to the overall dataset seem to be introspective and the converse can be observed in the sarcastic topics. This aligns with what is known intuitively about sarcasm when published online, it is often intended to attain attention from the reader compared to non-figurative text conveying the same message.

The relative affinities of each topic learned from the whole dataset were compared for sarcastic and non-sarcastic text prompts and detailed in table 18. Topics 3 and 4 which are more introspective were identified to have a significantly lesser affinity to sarcastic content, consolidating observations regarding the distinctions between the two topic modelling outcomes.

This information provides insight into the general nature of sarcasm, however given the wide range of subjects discussed in the context of the task, results are broad and subjective. For this reason, the reported observations cannot be afforded significant weight in the context of the overall problem set; a focus on the more objective and robust quantitative results will be implemented.

Table 14 Statistical Evaluation of Contextual Indicators of Sarcasm.

Sarcastic Content			Non-Sarcastic Content			Significant difference between Sarcastic and Non-Sarcastic Content		
Overall	Positive Subset	Negative Subset	Overall	Positive Subset	Negative Subset	Overall	Positive Subset	Negative Subset
Topic 1 – Overall Topics								
0.344	0.352	0.339	0.348	0.342	0.354	No	No	No
Topic 2 – Overall Topics								
0.244	0.260	0.233	0.207	0.215	0.201	No	No	No
Topic 3 – Overall Topics								
0.187	0.215	0.168	0.218	0.217	0.219	Yes	No	Yes
Topic 4 – Overall Topics								
0.226	0.173	0.262	0.226	0.225	0.227	No	Yes	No

6.4 Evaluation of Sarcastic Text Labelling Strategies

The literature review highlighted validity concerns regarding previous convention with regards to obtaining data labelled as sarcastic and non-sarcastic. While it is known that the use of tags like

#sarcasm and #irony to obtain positively labelled data for classification yields an unrepresentative training dataset of sarcastic content, no work could be identified which evaluated this impact. Given the iSarcasm dataset presents the most robust methodology to obtain sarcastic labelled data which is as representative as possible of organic sarcastic content, comparative work has been carried out using this dataset as a benchmark for comparison. This section has two aims:

- Compare quantitative features of the iSarcasm dataset sarcastic text to the survey results. Critically evaluate the results to assess the survey methodology.
- Assess the impact, if any, a poor annotation strategy has on the features of the sarcastic labelled data.

6.4.1 Survey Methodology

Of the features evaluated, 66% were found to have no deviation between the iSarcasm dataset and the survey results. Given the sampling of the survey text prompts originated from a subset of the iSarcasm dataset which contained no emojis, this may explain some of the observed incongruence. Features which signify tone were the primary sources of significant difference between the two sets. Hashtags, laughter indicators, affirmatives, negations, intensifiers, interjections, and mid-word capitalisations were found at varying frequencies in the sarcastic content. As these features play a role in conveying tone, the reason may relate to the original author feeling that their intended tone was sufficiently evident without further clarification, or there may be a relationship between syntactic style and their likelihood to use emojis in general.

Analysis comparing these features occurrences between sarcastic tweets with and without emojis did not show significant deviation, so these distinctions between datasets are unlikely to indicate concern regarding the survey methodology.

6.4.2 Hashtag Annotation Strategy

Initial evaluation of a dataset which utilising the dominant annotation convention; weak labelling using #sarcasm and #irony displayed significant shortcomings regarding the strategy. Table 15 highlights the significant differences between the features between the hashtag annotated dataset compared to the human-annotated set: 72% of features were found to be significantly different to the baseline dataset. This result provides evidence that sarcasm detection models trained using datasets labelled in this manner are unlikely to be effective in identifying organic sarcasm due to the unrepresentative features of the data in these datasets. The scope of impact is difficult to accurately assess, but given the sole dataset identified using more robust human-annotation is relatively small

(777 sarcastic tweets, 3707 non-sarcastic tweets), the scope of these findings likely impacts a significant majority.

This is likely to artificially inflate the reported results. Where hashtag or keyword labelling is used, these features will be common across all positively labelled data and sparse or absent in the negatively labelled data. This vastly reduces the burden of the models to learn more complex patterns, reducing the task to identifying the presence of key tokens in strings. This may account instances where high accuracies are reported using simplistic traditional machine learning models – which would be unexpected given the complexity of the task. To challenge this hypothesis, a review of the annotation strategies used for each study highlighted in table 1. Where the data annotation strategy was disclosed, there was only one work identified which avoided the use of data using this strategy (Abercrombie and Hovy, 2016). The average reported accuracies for models using hashtag or keyword annotation ranged from 79-96%, which is significantly greater than the instance which used human-annotated data at 60% accuracy. A secondary observation is that the models using hashtag or keyword annotation seem to follow a loose pattern where the use of labels like #sarcasm and #irony perform better and studies where labels are slightly more ambiguous report lesser accuracies (e.g. use of #funny or #not). As these words may additionally appear in randomly sampled negatively labelled data following preprocessing which removes hashtags the reduction in accuracy is logical.

Additional data from alternative datasets is assessed in section 7.3.1 which provides supplementary evidence that the features using these strategies differ significantly from human-annotation regardless of the specific strategy used.

Table 15 Comparison of Sarcastic Text Features between datasets.

Result						Statistically Significant Difference					
iSarcasm			Dataset annotated using hashtags			iSarcasm			Dataset annotated using hashtags		
Overall	Positive Subset	Negative Subset	Overall	Positive Subset	Negative Subset	Overall	Positive Subset	Negative Subset	Overall	Positive Subset	Negative Subset
Emoji Use Frequency¹											
1.35	1.47	1.21	0.102	0.217	0.0449	Yes	Yes	Yes	Yes	Yes	Yes
Position of Emojis in Text											
0.895	0.898	0.893	0.976	0.943	0.992	No	No	No	Yes	Yes	Yes
Sentiment Score of Emojis Used											
0.160	0.307	-0.0691	0.269	0.303	0.189	Yes	No	No	Yes	No	Yes
Degree of Positivity of Emojis Used											
0.361	0.447	0.227	0.405	0.429	0.346	No	No	Yes	Yes	No	Yes
Degree of Negativity of Emojis Used											
0.201	0.140	0.296	0.135	0.127	0.156	No	No	No	Yes	No	Yes
Table 15 continued on the next page.											

Result						Statistically Significant Difference					
iSarcasm			Dataset annotated using hashtags			iSarcasm			Dataset annotated using hashtags		
Overall	Positive Subset	Negative Subset	Overall	Positive Subset	Negative Subset	Overall	Positive Subset	Negative Subset	Overall	Positive Subset	Negative Subset
Degree of Neutrality of Emojis Used											
0.379	0.368	0.396	0.401	0.361	0.498	No	No	No	No	No	Yes
Degree of Anger Expressed through Emoji											
0.0666	0.0687	0.0634	0.0684	0.0668	0.0724	No	No	No	No	No	Yes
Degree of Anticipation Expressed through Emoji											
0.0757	0.0771	0.0736	0.0772	0.0750	0.0824	No	No	No	No	No	Yes
Degree of Disgust Expressed through Emoji											
0.0551	0.0563	0.0531	0.0566	0.0544	0.0619	No	No	No	No	No	Yes
Degree of Fear Expressed through Emoji											
0.0655	0.0672	0.0629	0.0670	0.0650	0.0717	No	No	No	No	No	No
Degree of Joy Expressed through Emoji											
0.0795	0.0795	0.0796	0.0787	0.0764	0.0841	No	No	Yes	No	Yes	Yes
Degree of Sadness Expressed through Emoji											
0.0656	0.0675	0.0627	0.0666	0.0648	0.0711	No	No	No	No	No	Yes
Degree of Surprise Expressed through Emoji											
0.0683	0.0694	0.0665	0.0686	0.0666	0.0734	No	No	No	No	No	Yes
Degree of Trust Expressed through Emoji											
0.0782	0.0790	0.0771	0.0791	0.0763	0.0859	No	No	No	No	No	Yes
Average Text-Emoji Sentiment Incongruence – Positivity Score											
0.299	0.371	0.205	0.264	0.360	0.216	No	No	No	No	No	No
Average Text-Emoji Sentiment Incongruence – Negativity Score											
0.257	0.153	0.391	0.251	0.208	0.273	No	No	No	No	Yes	Yes
Average Text-Emoji Sentiment Incongruence – Neutrality Score											
0.236	0.241	0.229	0.190	0.251	0.160	Yes	No	Yes	Yes	No	Yes
Average Text Sentiment Score											
0.159	0.719	-0.558	-0.0655	0.588	-0.390	Yes	Yes	No	Yes	Yes	Yes
Average Text Positivity Score											
0.462	0.766	0.0740	0.270	0.624	0.0940	Yes	No	No	Yes	Yes	Yes
Average Text Neutrality Score											
0.235	0.188	0.294	0.395	0.341	0.421	Yes	Yes	No	Yes	Yes	Yes
Average Text Negativity Score											
0.303	0.0463	0.632	0.335	0.0353	0.485	No	Yes	Yes	No	Yes	Yes
Average Tweet Length											
19.2	18.2	20.4	15.4	14.3	15.9	No	No	No	Yes	Yes	Yes
Average Number of Hashtags²											
0.189	0.228	0.139	2.19 1.19	2.57 1.57	2.00 1.10	Yes	Yes	Yes	Yes	Yes	Yes
Average Number of Laughter Indicators											
0.00610	0.0109	0.000	0.0120	0.0120	0.0120	Yes	Yes	Yes	Yes	Yes	Yes
Average Number of Capitalised Words											
2.02	1.82	2.28	2.44	2.21	2.55	No	No	No	Yes	Yes	No

Table 15 continued on the next page.

Result						Statistically Significant Difference					
iSarcasm			Dataset annotated using hashtags			iSarcasm			Dataset annotated using hashtags		
Overall	Positive Subset	Negative Subset	Overall	Positive Subset	Negative Subset	Overall	Positive Subset	Negative Subset	Overall	Positive Subset	Negative Subset
Average Number of User Mentions											
0.360	0.348	0.375	0.500	0.386	0.557	Yes	Yes	Yes	Yes	Yes	Yes
Average Instances of Pragmatically Relevant Punctuation											
0.372	0.337	0.417	0.448	0.301	0.521	No	No	No	Yes	No	Yes
Average Instances of Affirmatives											
0.524	0.500	0.556	0.332	0.283	0.356	No	Yes	No	Yes	Yes	Yes
Average Instances of Negations											
0.659	0.500	0.861	0.508	0.301	0.611	No	Yes	Yes	Yes	Yes	Yes
Average Instances of Intensifiers											
0.238	0.196	0.292	0.164	0.133	0.180	Yes	Yes	Yes	Yes	Yes	Yes
Average Instances of Interjections											
1.122	0.870	0.144	0.788	0.867	0.749	Yes	Yes	Yes	Yes	Yes	Yes
Average Instances of Mid-Word Capitalisation											
0.707	0.576	0.875	1.77	1.63	1.84	Yes	No	Yes	Yes	Yes	Yes

¹Given the survey questions were sampled from a subset of the iSarcasm dataset (tweets with no emojis), the converse subset was used for this evaluation to avoid overlap of features. Reported results for iSarcasm emoji use frequency is therefore skewed and unrepresentative of a realistic value. For this reason, these reported values were excluded from the calculation of aligned features for the two datasets.

²Given the sampling of the text for the dataset relies on the presence of #sarcasm or #irony for inclusion, the dataset reports values disproportionately high compared to natural hashtag use rates. In every instance either hashtag appeared once only therefore the values used for statistical evaluation considered comparison both with and without these labels. When assessing the feature for a statistically significant difference.

6.5 Chapter Conclusion

This chapter established features which are significantly different between sarcastic and non-sarcastic tweets using data obtained from a survey. The identified differences between features in sarcastic and non-sarcastic content were consistent with intuitive outcomes. These features are of value to identify components of text which may provide value in subsequent sarcasm detection. This work additionally identified the importance of context on the presentation of sarcasm; where its presentation is notably different in positive and negative content and more likely to be expressed in topics which are polarising.

The survey methodology proposed implemented a method to integrate emojis into sarcastic and non-sarcastic content which aimed to capture data more representative of organically occurring sarcasm on Twitter than previous convention of annotation using keywords or hashtags and was less labour intensive for participants than previous works which use manual identification of sarcasm in Twitter users previously published tweets, based on author classification. Good alignment was observed in features evaluated between the survey results and the baseline, providing positive indications for the validity of the survey results and thus the results are usable for later sarcasm detection model training.

Conversely, the dataset evaluated using hashtag annotation displayed significantly different features across all categories assessed, providing strong indicators that this method does not yield content which is representative of organic sarcasm on Twitter. An expansion of this analysis considering annotation strategy alongside reported accuracies for prominent literature showed significant impacts of this strategy on outcomes. Given the evidence that these models do not truly detect organic instances of sarcasm, their reported accuracies were not considered when identifying current state-of-the-art sarcasm detection.

This outcome of this chapter provides insight into trends which characterise sarcasm on Twitter in addition to highlighting the impact of annotation strategy on the resulting training dataset and by extension the final model.

7 Integration of Emoji Pragmatics into Sarcasm Detection

This chapter aims to combine all observations made to this point to identify and implement a sarcasm detection solution. Such a solution will integrate measures to ensure a valid training dataset, robust model selection and evaluation process and novel architectural components which consider features of sarcasm identified throughout the analysis to this point which cannot be effectively captured by current proposed models.

7.1 Proposed Novel Methodology

Work carried out to date has identified several features which may improve outcomes for sarcasm detection. Chapter 6 concluded that collection methodologies for training data have significant implications for the data obtained in terms of the structure and sentiment features. Based upon this assessment, expansions upon the current training dataset must be carried out mindfully to ensure that the characteristics of organic sarcastic data are retained. Additional observations regarding features which have a statistically significant difference in sarcastic and non-sarcastic text were identified; this will form the basis for feature extraction prior to model training. Additional observations which will be subject to evaluation for consideration in the proposed model include:

- Both semantics and sentiment have been identified as features with distinct markers in sarcasm. Word vectors are limited in their capacity to effectively convey both semantic relationships and sentiment concurrently; such an effect is fundamental to the nature of language; where sentiment of two words is opposing, the words may be semantically linked. E.g. *good* and *bad* which are semantically adjacent however the sentiment is opposite.
- Greater subjectivity is observed where the topic relates to personal beliefs rather than more generalised humour. An observation relating to this effect is that the belief held by the majority seems to be classified as non-sarcastic at higher rates and the converse is true where the belief is regarded as more controversial. There were notable differences in the use of emojis in these cases- sentiment congruence was high between emojis and text in the non-sarcastic content and the opposite was true for the sarcastic content.
- The presentation of sarcasm varies based upon context. Negative sarcastic tweets were observed to use emojis disproportionately to reduce perceived negativity. The converse is true for positive sarcastic tweets. This observation implies incongruence of sentiment may be a feature of importance.

7.2 Proposed Architecture

7.2.1 Model Selection

Given the complexity of the task and prevalence of similar architectures identified in literature, neural networks will be the model class evaluated for the task. Selection criteria will consider the architectural features with respect to the task in addition performance in an initial evaluation.

7.2.2 Sentiment-Aware Attention Mechanism

This section proposes an approach to ensure both semantic and sentiment information can be considered for the purpose of sarcasm detection as previous evaluation has determined that both features are likely to play a role in understanding the underlying patterns in sarcastic content. The consideration of two sets of word vectors, optimised for semantic and sentiment information respectively is a possible solution for exploration, which may enable a more nuanced representation of the words by the model. However, there are limitations to this approach; this would significantly increase complexity and data requirements for the task. Additionally, where the vectors contain overlapping information, there may be interference, reducing model performance necessitating increasingly robust measures against noise which would likely impede the learning of subtle nuances which characterise sarcasm. This evaluation leads to a conclusion that a better approach would consider these features in a manner which does not include additional word vectors.

The fundamental purpose of attention mechanisms is to mirror cognitive attention within text. Attention mechanisms are not typically utilised for the purpose of enhancing the sentiment awareness of a model, however in this context, an adapted mechanism poses potential to ensure both sentiment and semantic information can be considered in the model architecture. To achieve this, the traditional attention mechanism will be modified to weight word importance with regards to their polar sentiment. The use of varied weighting based on polar sentiment intensity, alongside context weights allow the model to weight tokens which are of importance based on their significance with regards to the strength of sentiment they convey in addition to information they add to the string. The result may address the primary challenges for sarcasm detection.

7.3 Data Preparation

7.3.1 Expansion of Current Training Dataset

Evaluation to this point has established that sarcasm detection is a highly complex process, and thus is likely to require a large dataset for training. Previous work in chapter 6 has established that annotation strategies which rely on weak labelling using hashtags yield an unrepresentative training dataset. However, this does not necessarily imply that no data captured using these methods is

representative. This section aims to evaluate several datasets annotated for sarcasm detection using the present convention to evaluate the consistency of observations made previously and identify any text which is aligned with observations about the human-annotated baseline dataset. The annotation strategies for the evaluated datasets are as follows:

1. Annotation based on the presence of #sarcasm, #sarcastic or #irony in the text.
2. Annotation of based upon the presence of #sarcastictweet and #not in addition to a set of offensive vocabulary words.
3. Annotation strategy based on the presence of key words and hashtags in addition to semi-supervised learning techniques.
4. Annotation strategy based on the presence of key words and hashtags in addition to semi-supervised learning techniques.
5. Annotation based on the idea that sarcastic content consists of text containing both positive and negative verb phrases in the same document (tweet) in addition to a set of key words.

7.3.1.1 Statistical Evaluation to Identify Aligned Features

To identify features which differ significantly in these datasets compared to the baseline, non-aligned text features can be highlighted using statistical tests. The results can subsequently be used to evaluate impacts in greater granularity of the poor annotation strategy in addition to identifying data which aligns with the characteristics of the data obtained from the validated methods. Statistical analysis was implemented with the following adjustments to fit the context of the data:

- Where measuring instances of a feature, the minimum value for the lower limit of the range at 95% confidence was defined as zero to align with what is logical in this context.
- Rounding of the results to up the nearest integer was utilised in cases where metrics represent integer values. Justification for this action is clear considering the example of the hashtags per tweet parameter; the range at 95% confidence is defined as $0.00 < x < 0.967$ which results in the exclusion of all instances where a hashtag occurs, which is not necessarily valid.

Table 16 Baseline for Evaluation of Tweets for Organic Sarcasm Features.

	Mean		Standard Deviation		Range at 95% confidence	
	Positive Subset	Negative Subset	Positive Subset	Negative Subset	Positive Subset	Negative Subset
Emoji-Based Features						
Emojis Per Tweet	0.569	0.507	0.803	0.680	UL: 2.17 LL: 0.00	UL: 1.87 LL: 0.00
Sentiment Score	0.323	-0.0514	0.412	0.413	UL: 1.15 LL: -0.500	UL: 0.775 LL: -0.878
Degree of Positivity	0.466	0.261	0.255	0.200	UL: 0.977 LL: 0.00	UL: 0.661 LL: 0.00
Degree of Negativity	0.143	0.312	0.178	0.229	UL: 0.498 LL: 0.00	UL: 0.770 LL: 0.00
Degree of Neutrality	0.391	0.427	0.155	0.118	UL: 0.701 LL: 0.0800	UL: 0.662 LL: 0.191
Text-Based Features						
Degree of Positivity	0.667	0.0707	0.282	0.0698	UL: 1.23 LL: 0.102	UL: 0.210 LL: 0.00
Degree of Negativity	0.0520	0.589	0.0695	0.246	UL: 0.191 LL: 0.00	UL: 1.08 LL: 0.00
Degree of Neutrality	0.281	0.340	0.247	0.205	UL: 0.775 LL: 0.00	UL: 0.751 LL: 0.00
Hashtags per Tweet	0.164	0.104	0.637	0.431	UL: 1.44 LL 0.00	UL: 0.967 LL: 0.00
Laughter Markers per Tweet	0.0336	0.0116	0.211	0.107	UL: 0.455 LL: 0.00	UL: 0.226 LL: 0.00
Affirmatives per Tweet	0.502	0.533	0.844	0.828	UL: 2.19 LL: 0.00	UL: 2.19 LL: 0.00
Negations per Tweet	0.379	0.651	0.779	1.06	UL:1.94 LL: 0.00	UL: 2.78 LL: 0.00
Intensifiers per Tweet	0.247	0.320	0.483	0.678	UL: 1.21 LL: 0.00	UL: 1.67 LL: 0.00
Interjections per Tweet	1.08	1.70	1.74	1.70	UL: 4.57 LL: 0.00	UL: 4.78 LL: 0.00
Relevant Punctuation per Tweet	0.423	0.528	1.03	1.29	UL: 2.59 LL: 0.00	UL: 3.11 LL: 0.00
User Mentions per Tweet	0.227	0.258	0.584	0.754	UL: 1.40 LL: 0.00	UL: 1.77 LL: 0.00
Capitalised Words per Tweet	2.00	2.13	2.19	2.28	UL: 6.38 LL: 0.00	UL: 6.69 LL: 0.00
Mid-Word Capitalisations per Tweet	0.551	0.603	1.35	1.69	UL: 3.25 LL: 0.00	UL: 3.94 LL: 0.00

Previous chapters establish that sarcasm presents differently where there is positive and negative sentiment in the text. For this reason, evaluation of each dataset has been broken down into these

subsets for a more granular approach to the task. Figures 17 and 18 show results of the analysis for each dataset.



Figure 17 Atypical Feature Identification in Datasets Annotated using Hashtag Strategy by Feature.

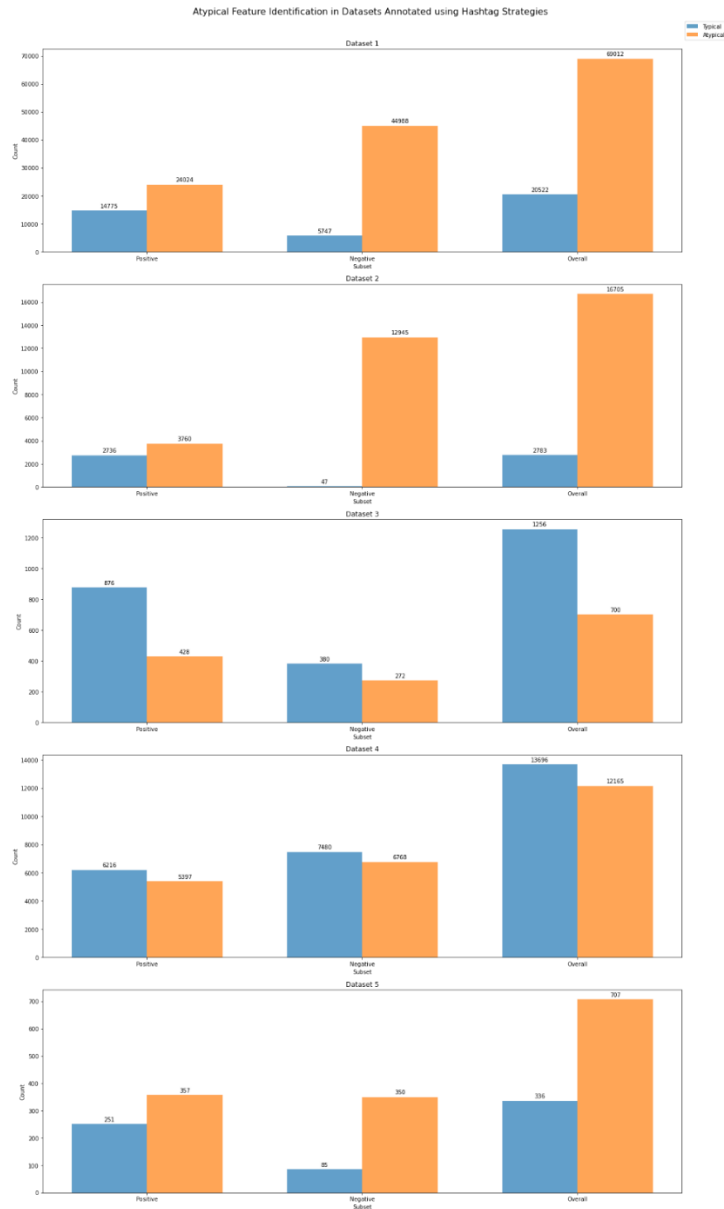

Figure 18 Atypical Feature Identification in Datasets Annotated using Hashtag Strategy by Subset.

7.3.1.2 Results

In every case a significant proportion of text prompts were found to contain atypical presentations of sarcasm based on the established baseline from the results contained in the datasets which utilised human-annotation methods. Given the more aligned results observed for datasets 3 and 4, the addition of machine learning improves outcomes for training data collection. Details with regards to the techniques were not detailed within the literature therefore greater depth of evaluation is difficult. Across all five datasets, 72% of the tweets were found to display incongruent characteristics compared to the present gold-standard collection strategy used in the iSarcasm dataset. The consistency of outcome across each evaluated dataset further reinforces the limitations of the

annotation strategy. Atypical features were identified across most categories evaluated indicating that additional processing steps to mitigate the impacts would not be viable to address the limitations.

For the purposes of expansion upon the present training dataset, a cautious approach was implemented which includes only data which has no features which present atypically compared to the defined baseline. This yielded an additional 38593 sarcastic tweets for consideration during model training.

This strategy ensures that the bias associated with poor annotation strategy is mitigated, however the results are limited to align with the characteristics of the previously validated data. In any instance using this strategy, the scope of what is represented in the final dataset is limited to what aligns with the baseline. Where some valid instances of organic sarcasm are unrepresented in the baseline, they will be excluded from the collected data also. However, this serves to exclude data which is unrepresentative of how sarcasm usually presents; it is not typical for sarcastic content to contain hashtags like #sarcasm therefore the training data should reflect this. Expansion upon the availability of human-annotated data in future would serve to improve outcomes for representation of organic sarcasm within the dataset, leading to a more comprehensive understanding of patterns which are present in sarcastic content.

7.3.2 Data Cleaning

To ensure patterns learned for sarcastic content are as robust as possible, it is important to ensure that the data is processed appropriately prior to model training. The process for cleaning was dependent on the type of model to be trained. These processes have been detailed in section 11.10. Following the data cleaning process, a control subset was generated which omitted all emojis from the text.

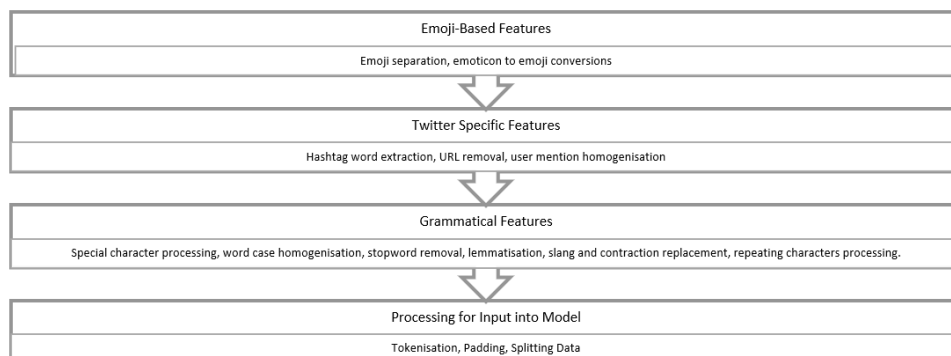

Figure 19 Data cleaning steps for neural network model training.

7.4 Baseline Model Evaluation

7.4.1 Neural Network Selection

Neural networks are a primary area of potential identified in literature for sarcasm detection tasks, with the primary models used being CNN, LSTM and GRU models. Suitability based on their respective architectures are evaluated in section 11.10.4. Each identified model was hyperparameter tuned using a similar methodology to that which was described previously in section 11.4.5, with the goal of identifying the most optimal model with regards to accuracy and generalisation.

Following hyperparameter tuning, three models with the greatest accuracy performance metrics were re-trained using 5-fold cross validation to evaluate their robustness to varied data. The results were used to identify the optimal model.

7.4.2 Evaluation Metrics

The assessment metrics were adjusted to account for the nature of the task: binary classification. During hyperparameter tuning accuracy was the primary metric used to evaluate model performance. The metric reports the proportion of correct predictions made by the model. This was selected based on the ease of interpretation and its suitability given the balanced nature of the dataset.

$$Accuracy = \frac{True_{pos} + True_{neg}}{True_{pos} + True_{neg} + False_{pos} + False_{neg}}$$

Following initial tuning, during the assessment of models with varying data input, F1 score was additionally considered which provides insight into the precision and recall of the model.

$$Precision = \frac{True_{pos}}{True_{pos} + False_{pos}}$$

$$Recall = \frac{True_{pos}}{True_{pos} + True_{neg}}$$

$$F_1 = \frac{Precision \times Recall}{Precision + Recall}$$

Initial evaluation during the hyperparameter tuning process identified the GRU model as achieving maximum accuracy while minimizing loss. To balance computational cost with assessment of as many iterations of the model as possible during hyperparameter tuning cross validation was performed on the three models identified with the greatest performance and the final optimal results was selected from this pool.

7.4.3 Model Performance

Initial evaluation during the hyperparameter tuning process identified the GRU models as the best performing, which is aligned with expectations with respect to their architectural features and literature assessment.

Layer (type)	Output Shape	Param #
input_10 (InputLayer)	[(None, 38)]	0
embedding_27 (Embedding)	(None, 38, 300)	11515800
gru_46 (GRU)	(None, 38, 256)	428544
dropout_42 (Dropout)	(None, 38, 256)	0
gru_47 (GRU)	(None, 38, 128)	148224
dropout_43 (Dropout)	(None, 38, 128)	0
gru_48 (GRU)	(None, 38, 64)	37248
dropout_44 (Dropout)	(None, 38, 64)	0
gru_49 (GRU)	(None, 38, 64)	24960
dropout_45 (Dropout)	(None, 38, 64)	0
flatten_9 (Flatten)	(None, 2432)	0
dense_17 (Dense)	(None, 1)	2433

Total params: 12,157,209
 Trainable params: 12,157,209
 Non-trainable params: 0

Figure 20 Optimal baseline GRU Model for Sarcasm Detection.

Although this was the best outcome for the assessed models, evaluation of results displays overfitting and general instability. Over the duration of training, loss and accuracy were unstable, indicating the model was not learning robust features.

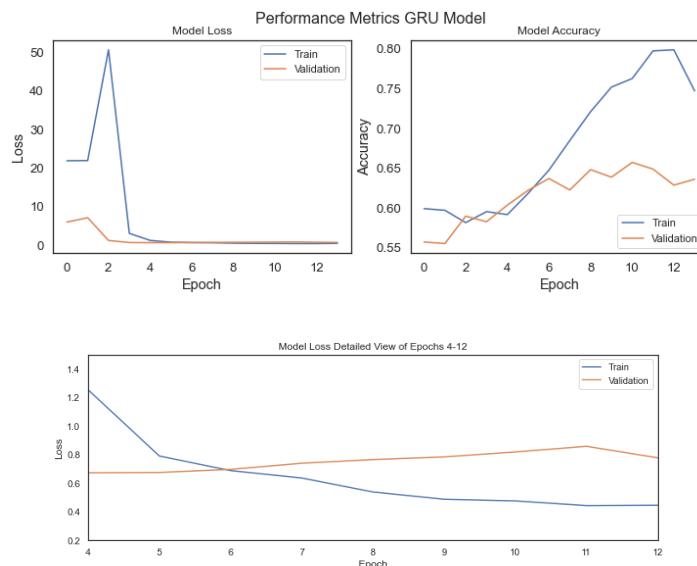

Figure 21 Training Profile of Optimal GRU model.

The model achieved accuracy of $\approx 63\%$ on unseen data which, in the context of binary classification indicates a model that can to some extent discriminate between sarcastic and non-sarcastic content, as the accuracy consistently exceeds 50%; random classification. The achieved accuracy is marginally

greater than the only comparable model identified in literature using valid training data however overall, this is not good performance in the context of a binary classification. Given the models instability, performance on unseen data cannot be stated with certainty, thus is an undesirable solution.

Table 17 Performance Metrics of Optimal GRU Model for Sarcasm Detection on unseen data.

Accuracy	0.6255
F1 score	0.6829

This approach used word vectors as the sole source of information to train the model, which may result in over-reliance on semantic information and disregard for previously highlighted limitations of the word vectors. Further adaptations to the model which enable enhanced consideration of context and sentiment. Section 7.5 discusses the implementation of a strategy to provide enhanced sentiment awareness to the model.

7.5 Attention Mechanism

7.5.1 Architecture

To integrate sentiment awareness into the model minimising additional noise, an attention mechanism which weights word vectors using the sentiment and contextual importance.

Sentiment metrics selected for use in this layer were limited to positive and negative intensity. Such a selection directly addresses the limitations of adjacent semantics and opposing sentiment, in addition to providing means to learn patterns relating to sentiment incongruency, differing presentation of sarcasm in positive and negative contexts which have each been observed to contribute to patterns in sarcasm. The scope of this evaluation was limited to the use of parameters based on dimensional theory as they were shown to have more significant differences between sarcastic and non-sarcastic text. Evidence relating to basic theory was more limited. Given this observation, the trade-off between increasing computational complexity and likelihood of noise against the increased granularity of the data which enhance learning of subtle patterns indicated that the results were not likely to yield favourable results from their inclusion.

The values previously generated in chapter 5 were limited to emojis only; no dataset could be identified which contains predictions for the up-to-date corpus therefore this resource is of significant value for such a task. Word values were obtained from the SentiWordNet dictionary (Esuli and Bond, 2022) which provides positive and negative sentiment intensity values for a large word corpus. Sentiment data was converted to embeddings and scaled to integer values for ease of interpretation:

$$I_p, I_n = \begin{cases} (50 \times x) + 1 & \text{if } x \neq 1 \\ 50 & \text{if } x = 1 \end{cases}$$

Where I_p and I_n represent the positive and negative sentiment intensity of the words respectively and larger values indicate greater intensity towards the given sentiment. Out-of-vocabulary words were represented by 0, indicating an objective word. Given an input string:

$$t = [t_1, t_2, t_3, \dots, t_n]$$

Two sentiment embeddings (s_n^p, s_n^n) containing I_p and I_n respectively can be constructed for string t :

$$t = [t_1, t_2, t_3, \dots, t_n] \rightarrow \begin{cases} s_x^p = [I_1^p, I_2^p, I_3^p, \dots, I_n^p] \\ s_x^n = [I_1^n, I_2^n, I_3^n, \dots, I_n^n] \end{cases}$$

The embeddings are introduced into the attention layer of the optimised GRU model and the weighted contribution of the sentiment of each word is determined via a matrix multiplication between the sentiment values and the weight matrix:

$$Q_i \left(\begin{array}{cc} \downarrow A & B \downarrow \\ C & D \end{array} \right) \times \begin{pmatrix} \rightarrow E & F \\ G & H \\ \rightarrow \end{pmatrix} = \begin{pmatrix} AE + BG & AF + BH \\ CE + DG & CF + DH \end{pmatrix}$$

Which is subsequently adjusted by a bias term:

$$W_x^c = (Q_x \cdot W_x) + b_x$$

Where:

$$x \in \{o, s_p, s_n\}$$

Where o represents the output of the GRU layer and s_p and s_n represent positive and negative sentiment intensity embeddings respectively. Each respective transformation is calculated using independent weight and bias to enable varying importance to be assigned in each case, providing a more flexible framework for optimisation during model training. The summation of these weights is obtained, and a hyperbolic tangent function is applied:

$$u_i = \tanh(W_o, W_{s_p}, W_{s_n})$$

Where:

$$\tanh(z) = \frac{\sinh(z)}{\cosh(z)} = \frac{e^z - e^{-z}}{e^z + e^{-z}}$$

This introduces non-linearity to the model, increasing its capacity to learn complex patterns which cannot be entirely represented by linear relationships. Without the use of an activation, n model layers can be reduced to a single linear layer, which mirrors linear regression thus is only capable of learning linear relationships within the feature space.

Given the definition of linear regression:

$$y = mx + c$$

Two linear layers can be reduced to a single linear layer as follows:

$$y = (xW_1 + b_1)W_2 + b_2 = xW_1W_2 + (b_1W_2 + b_2) = xW' + b'$$

Where $W' = W_1W_2$ and $b' = b_1W_2 + b_2$. Such a definition can be extended to n by induction. The hyperbolic tangent activation specifically was selected for the introduction of non-linearity due to its mapping of values to a range of -1 to 1 which mitigates instability and exploding gradients, which is not achieved by alternatives such as the sigmoid function. The function was widely prevalent within literature for similar implementations within neural network and attention architectures.

A softmax function is applied to the output of the hyperbolic tangent function to convert unnormalized attention scores into interpretable probability distributions, which can be added to a total of 1, where greater probability is assigned to higher scores:

$$\alpha_i = \frac{\exp(u_i)}{\sum_{j=1}^l \exp(u_j)}$$

Where attention weights, α_i represent the contribution of each token in the string to the final text representation. Finally, the attention weights are applied to the input word vectors:

$$f_i = \sum_{i=1}^l \alpha_i o_i$$

This approach allows the model to learn the most relevant semantic information from the vectors in addition to considering the sentiment information for its prediction. The use of sentiment determined externally to the model enables the model to learn based off prior knowledge learned from word tokens previously, while also considering the most computationally efficient method to introduce information which highlights tokens which may be of importance to identify sentiment incongruity in addition to contextually important aspects of the string.

7.5.2 Model Performance

Evaluation metrics indicate the introduction of the attention layer to the model was effective in improving the models' performance for the purposes of sarcasm detection. On an identical training dataset, the increased sentiment information and context weighting afforded by the attention layer yielded a 15.8% improvement in accuracy. The training profile of the model implied increased robustness in pattern recognition and decreased overfitting, implying the sentiment information and

sentiment-context weighting was a key limitation of methodologies which rely solely on semantic information within word vectors.

Layer (type)	Output Shape	Param #	Connected to
input_419 (InputLayer)	[(None, 38)]	0	[]
embedding_238 (Embedding)	(None, 38, 300)	11515800	['input_419[0][0]']
gru_210 (GRU)	(None, 38, 256)	428544	['embedding_238[0][0]']
dropout_16 (Dropout)	(None, 38, 256)	0	['gru_210[0][0]']
gru_211 (GRU)	(None, 38, 128)	148224	['dropout_16[0][0]']
dropout_17 (Dropout)	(None, 38, 128)	0	['gru_211[0][0]']
gru_212 (GRU)	(None, 38, 64)	37248	['dropout_17[0][0]']
dropout_18 (Dropout)	(None, 38, 64)	0	['gru_212[0][0]']
gru_213 (GRU)	(None, 38, 128)	74496	['dropout_18[0][0]']
input_420 (InputLayer)	[(None, 38, 128)]	0	[]
input_421 (InputLayer)	[(None, 38, 128)]	0	[]
sent_aware_attention_34 (SentAwareAttention)	((None, 38, 1), (None, 300))	498	['gru_213[0][0]', 'input_420[0][0]', 'input_421[0][0]', 'embedding_238[0][0]']
dense_64 (Dense)	(None, 1)	301	['sent_aware_attention_34[0][1]']

Total params: 12,285,111
 Trainable params: 12,285,111
 Non-trainable params: 0

Figure 22 Optimal GRU Model for Sarcasm Detection with Attention Layer.

Improvements are similarly observed in the F1 score; from 0.6829 to 0.7539 consolidating observations of increased performance and highlighting the enhancement of generalisation and overall performance of the adapted model. Results using this iteration of the model can be viewed with increased confidence in comparison to the previous model due to its significant and universal improvements in performance metrics in addition to indications of enhanced stability. Hence, it is likely that on unseen data the model would perform in a manner which is predictable and with better outcomes than current state-of-the-art models identified in literature.

Table 18 Performance Metrics of Optimal GRU Model for Sarcasm Detection with Sentiment-Aware Attention Layer on unseen data.

Accuracy	0.7256
F1 score	0.7539

7.6 Impact of Emojis on Model Performance

Given emojis are used disproportionately to convey tone, it is possible that sentiment incongruence may be more evident where their contribution to an input is considered. Presently, this information is under-utilised for sarcasm detection, despite this observation. Removal of the consideration of emoji from the training data yielded slight decrease in performance metrics; 1.9% and 1.4% decrease in accuracy and F1 scores respectively. Validation loss displayed a 13% increase where emojis were omitted, indicating that information obtained from emoji data is of importance in the generation of a robust model. Where emojis are not used, it is possible that accuracy on unseen data is similar based on the performance metrics, however the outcome on unseen data is much less predictable, thus their

contribution can be said to have a positive impact on model outcomes, although impact of their inclusion is evidently lesser than the attention layer. This may imply that postulation of improvement in performance of sarcasm detection tasks is related to their abilities to compensate for limited sentiment information in word vectors. Previous observations during word vector modification consolidate this concept, as the emoji vectors were found to perform well for the subsequent tasks without modification, whereas improvements were almost universal where modified word vectors were used; the emoji vectors are conveying sentiment to a greater extent than the word vectors and thus added additional sentiment information.

Table 19 Performance Metrics of Optimal GRU Model for Sarcasm Detection with Sentiment-Aware Attention Layer on unseen data.

Accuracy	0.7110
F1 score	0.7436

7.7 Chapter Conclusion

This chapter initially presented broad characteristics of sarcasm which contribute to its complexity for detection in Twitter content based upon work carried out in previous chapters. Characteristics of greatest importance were postulated to include sentiment features underrepresented in present models, and context. Such features were used to construct a novel sentiment-aware attention mechanism which enabled tokens within the text string to be weighted based upon their polar sentiment in addition to their contextual importance. A GRU neural network was selected for the task based upon prevalence in literature for similar tasks, architectural suitability, and performance in initial evaluation. The addition of the attention mechanism into the model yielded an improvement in accuracy $\approx 15.8\%$ and improved stability. Such an outcome consolidated hypothesis that sentiment may be an under-utilised component of sarcasm detection where standard word vector methodologies are implemented, which are prevalent in present literature. The impact can be attributed at least partially to the sentiment weights within the attention layer as a control test using only context vectors did not yield improved results from the model without attention. The final model was determined to outperform present state-of-the-art for sarcasm detection found in literature when measured against performance of words using valid training data.

The chapter concludes by addressing a core research question; *Can emojis be used to improve outcomes for sarcasm detection?* The omission of information relating to emojis from the dataset yielded a slight reduction in performance parameters, and more significant reduction in stability of the model leading to the conclusion that the inclusion of data relating to emojis is of value in the improvement of outcomes for sarcasm detection in Twitter content. Results imply that the

consideration of emojis towards sentiment-dependent NLP tasks may serve to enhance the sentiment information in the models, which is insufficient in word vectors alone. By nature emojis are uniquely suited to this task as they are used predominantly to convey tone and sentiment rather than exposition and hence can be considered to make a valuable contribution towards sarcasm detection in the proposed model.

Comparative work to measure performance under varying conditions in this chapter utilises a single baseline GRU model architecture, which was obtained during hyperparameter tuning, prior to the addition of the attention layer. Evaluation was carried out in this manner for the purposes of limiting time associated with hyperparameter tuning. This method demonstrates the efficacy of the proposed novel attention layer, however the final model reported may not necessarily be a true optimum without further hyperparameter tuning with the inclusion of the attention layer. Work in this chapter successfully demonstrates a novel methodology to integrate sentiment information into sarcasm detection models, which generates more robust models and improved performance.

8 Evaluation

8.1 Solution Strengths

A primary strength of the proposed methodology carried out in this work is that the generation of sentiment data relies minimally on human annotations. Prediction for both basic and dimensional theory parameters ultimately used for sarcasm detection was completed using information contained within the word vectors only, which were generated using the information supplied during each new release of emoji from the Unicode consortium. This enables the same method to be scaled for any new releases of emoji in the future without the requirement to generate supplementary human-annotated data.

The results of the proposed sarcasm detection model yielded a 73% accuracy with promising indications regarding robustness compared to the baseline model without attention or present best-performing models in literature using valid training data. Models where training data was collected using hashtag or keyword labelling were deemed to have significant limitations to their underlying methodology and thus it cannot be known the extent to which these models are capable of true sarcasm detection. For this reason, their reported performance was excluded from consideration.

The use of a sentiment-aware attention mechanism provides an additional strength to this approach. Outside of traditional machine learning methods, no strategies were identified which supplemented word vector information to address limitations. The methodology of leveraging additional knowledge relating to each word token has been shown to improve outcomes for sarcasm detection and reduce reliance on training data, which can be subject to bias. The approach taken is unique within the problem set of sarcasm detection, providing robust and improved outcomes compared to present literature. The flexibility in the architecture of the attention mechanism provides opportunities for further optimisation in future works.

8.2 Solution Limitations

A primary limitation of this work surrounds the limited data available for training. Prediction of basic and dimensional theory parameters in particular, relied on small sets of annotated data which limited the capacity for complex pattern recognition within the models and by extension, the overall accuracy of results. Reasonable accuracies were obtained despite this limitation; however, improvements could be made to the robustness of the presented methodology of this work where greater availability of annotated data was available. As the sarcasm detection model relies on data generated from prior regression models, high accuracies in any prediction model are of high importance in this case.

The architecture of the sarcasm detection model with sentiment-aware attention presented and the reported performance metrics are based upon the addition of the attention layer to the identified optimal model identified during hyperparameter tuning without attention. Such a decision was made due to the high computational cost of hyperparameter tuning complex models. The result demonstrates that the proposed attention layer improves outcomes for sarcasm detection, however, may not describe its maximum potential. It is likely that the implementation of hyperparameter tuning and expansion of the evaluated hyperparameter space would highlight a model which yields additional improvement upon the reported outcomes.

The attention mechanism proposed focuses on the supplementation of information relating to dimensional theory to the word tokens. Such a decision was made as prior analysis established these parameters were found to have statistically significant variance between sarcastic and non-sarcastic sets, and comparable information was available for the words within the vocabulary. The use of values for words generated using an alternative methodology than that of the emojis is one potential limitation, as this may not be an optimal 'like for like' comparison. This effect is likely minimal as the shape of KDE plots for each set was similar however this may introduce a certain degree of error. To remove this limitation the scope of the work in future could be expanded to include the prediction of words using the same model as the emojis. The prediction of parameters for words within the vocabulary in addition to the emojis may provide additional scope for the evaluation of other parameters within the attention layer which could not be included due to the lack of available of comparable parameters for words in certain cases, most notably metrics relating to basic theory. This is an area for future optimisation.

The use of attention weights can provide information regarding the degree of importance of the underlying sentiment, which is valuable in understanding concepts such as incongruity and limiting the use of additional sets of vectors or alternative information sources which may add greater noise. The approach however has not evaluated potential value of the use of the values themselves as model inputs. Sources in literature have evaluated this approach, with little indications of success, however the works are sparse, not carried out on data in the English language and implemented hashtag data labelling therefore the strategy cannot be entirely excluded based on these works.

9 Future Work

This work has established a baseline for a novel methodology for sarcasm detection which leverages the benefits of neural network architectures for complex pattern recognition in addition to supplementary knowledge of the word tokens found to be relevant to the task to weight token importance. Future expansion to this work which may address some of the limitations highlighted in section 8.2 include the acquisition of additional human-annotated data which would improve the robustness of outcomes and overall performance. More comprehensive hyperparameter tuning of the final model would also likely enhance outcomes.

A key area of opportunity is further development of the attention mechanism. Evaluation of the parameters used to apply weights to the tokens, may highlight a configuration which enhances pattern recognition further. This may involve further sentiment, grammatical or semantic features. This work would involve further depth evaluation of the limitations of the word vectors used for the work to highlight information, which is known to be of value, but may not be reflected in the training data used. Where a suitably large training dataset could be generated, it is additionally possible that more coherent topics may be obtained via a topic modelling method. The integration of this information may be of value given the known importance of context in sarcasm detection. This may additionally include the expansion of assessments to evaluate alternative word vectors, and modification processes.

Efforts were made to ensure the training data used in this work did not possess the same validity concerns as current conventional approaches; however, the use of data obtained from these sets with exclusion criteria based on the baseline dataset characteristics may not account for every aspect of the limitations of the data obtained using these methods. Use of human annotated data only in a future expansion of this work, or a more comprehensive assessment of criteria for exclusion may be valuable to understand the impacts of this approach, if any.

Finally, a more comprehensive evaluation of the potential of alternative base models such as CNN, LSTM, or transformer-based models could be carried out. These models each have been highlighted to have potential in literature, however the scope of this work focussed on the GRU model as it displayed the greatest initial potential.

10 Conclusion

The work carried out was able to achieve satisfactory outcomes for each research objective in addition to the overall research question. While limitations in options for feature extraction of emojis was cited as a key limitation in their utilisation across literature, initial phases of this work were able to establish viable feature extraction methodologies for emojis. The proposed strategy successfully leveraged information within word vectors for the purposes of sentiment feature extraction. The strategy implemented focused on obtaining quantitative metrics of value for sarcasm detection in addition to future scalability; the method leveraged no information which would be unavailable for emojis released in future. Results for this work enabled the consideration of emoji information in subsequent work and overcome the limitation of emoji use in text-processing more broadly.

Comprehensive feature analysis of sarcastic tweets was able to achieve several key outcomes. Features which have a statistically significant variance in presentation between sarcastic and non-sarcastic tweets were identified including sentiment-based features which consolidated postulations that sentiment is a critical component of sarcasm detection. This work highlighted the greater potential with regards to the use of parameters gleaned from dimensional theory models due to their greater deviations between sarcastic and non-sarcastic content. Secondly, this work was able to establish a baseline for the presentation of organic sarcastic content. This played a key role in highlighting limitations of present convention with regards to annotation strategy; a clear distinction between the data obtained using these methods and the baseline for organic sarcastic content on Twitter was highlighted.

Evaluation throughout the project highlighted several key factors which contributed to the complexity of sarcasm detection; the dual importance of semantic and sentiment information for the task limits the performance of models which rely solely on word vectors as they cannot comprehensively convey the relationships between semantically linked words with opposing sentiment in addition to limitations with regards to context available for short form online content. The proposed sarcasm detection pipeline successfully facilitates the task using a GRU neural network with sentiment-aware attention, at an accuracy of 73% and promising indications regarding model robustness as part of a framework which is easily scalable for the inclusion of any future emojis released. This result represents a 21.7% improvement upon the present optimal model accuracy in literature. Enhanced sentiment awareness was found to be a key factor in the improvement of performance with the consideration of emojis, with their disproportionate use to convey such emotion in text making them uniquely suitable for this task.

This work has successfully established evidence that pragmatic cues from emojis are a viable avenue to improve outcomes for sarcasm detection. Their consideration provides a significant improvement in the stability of the model due to their use to convey sentiment incongruence which lies at the core of sarcasm detection. This observation is core to the logic of the sentiment-aware attention mechanism and thus its efficacy consolidates conclusions relating to the overarching research question in addition to providing the final framework a state-of-the-art sarcasm detection model.

11 Appendix

11.1 Word Vector Selection

This section serves to supplement work in the body of the text and discusses in greater depth considerations which impact the vectors used in this work.

11.1.1 Consideration of Training Data

Availability of emoji vectors is sparse, however a majority train using short form online content such as tweets or Instagram captions. This methodology may have limitations for the purposes of sarcasm detection; incongruence in sentiment between emoji and text may be hard to identify in sarcastic content. Consider the following:

I love when I start choking on my water in my 8 person class 🍷

my guy smells like feet after the gym 🍷

My dream is to be left alone. 🍷

having a breakdown in the work bathrooms, hbu xx 🍷

While these emojis are intuitively positive, they are frequently used alongside negative text to clarify sarcastic intent. Where a high prevalence of incongruence between the sentiment of the text and certain emojis is found, training word vectors using adjacent text shows clear limitations. The vectors may interpret the emojis as having negative associations and thus the incongruence would be difficult to identify. It is unlikely that this would omit incongruence totally as there are no emojis which are used universally to convey sarcasm however emojis which are most frequently used in sarcastic content would be disproportionately impacted. The Emoji2Vec vectors were trained using official emoji descriptions, which largely omits any noise introduced by emojis being used in contexts contrary to their literal sentiment. However, these descriptions are highly literal and may not capture the nuances of certain use-cases. For the purposes of extraction of emotion data this is not necessarily important and ensuring a literal meaning for these emojis ensures sentiment incongruence is more readily identifiable which is important in this case.

The Google News Word2Vec vectors, trained on news articles are unlikely to be impacted to a significant extent by sarcasm hence by similar logic incongruence is likely to be identifiable using this selection. The developers of Emoji2Vec describe this as the most appropriate set of word vectors to be used alongside their vectors and thus this is a logical choice for use in the regression task. However, there are similar limitations with regards to their use in later sarcasm detection for Twitter content given the significant differences in vernacular used between the two sets of text.

11.1.2 Word Vector Bias

Word vectors by nature, carry the biases of the dataset for which they were trained. The impacts of this in the case of the emoji vectors are likely to be minimal given the descriptions which they are trained are highly objective, with no identified use of vocabulary that may introduce bias such as adjectives or adverbs. The converse is the case for the Google News vectors which have been shown to contain significant bias in terms of gender, socioeconomic status, and race (Bolukbasi *et al.*, 2016). This bias is important to retain within the data as it serves to add context, which is highly valuable to the detection of sarcasm, and sentiment more broadly. However, consideration must be given to whether biases within the media are also representative of that which would be found in the considered tweets. A comparative study relevant to this use-case is a potential area of expansion of this work in future, however the work of Curto *et al.*, 2022 comparing bias in Google News Word2Vec and Twitter GloVe Vectors can provide an indication of the impacts of bias in the word vectors. The work found that the variance in bias was minimal for many topics however the Google News vector displayed greater bias based on socio-economic status and the GloVe vectors displayed greater skew towards negative sentiment in the context of discrimination.

A process for optimisation vectors would not necessarily involve removal of all bias, but rather aim to match the bias of the population which the vectors will be used to evaluate. For sarcasm detection on Twitter, this would be a highly complex for topics where opinions are polarised; a vector cannot easily account for both views. Use of several sets of vectors trained based on different views may present a potential avenue to address this however this is outside the scope of this work due to the complexity of the undertaking due to the necessity to understand varying viewpoints of the Tweet author prior to vector selection. For the scope of this work the collection of such data would not fall into the scope of good ethical practice and potentially breach GDPR article 5(1) relating to data minimisation which dictates any data collection should be 'necessary' (EU Parliament, 2016). This adaptation may improve outcomes of highly complex large language models, however for the purposes of this project its necessity cannot be justified. The use of a trainable embedding layer will be implemented to optimise the vectors instead.

11.2 Word Vector Optimisation Process

This section supplements work in the body of the text which discusses the process of word vector space modification for emoji sentiment feature extraction.

11.2.1 Optimiser Selection

Given the complex nature in the relationships between sentiment and context playing a key role in pragmatics captured in word vectors, optimisation presents challenges with regards to definition of

objective functions and optimiser model selection. Two proposed loss functions outlined in section 5.4, aim to exploit known relationships between vocabulary to increase sentiment awareness. The complexity of the problem set, and high dimensionality of the vectors imply the loss landscape may contain many local minima which may increase the difficulty in locating the global minimum.

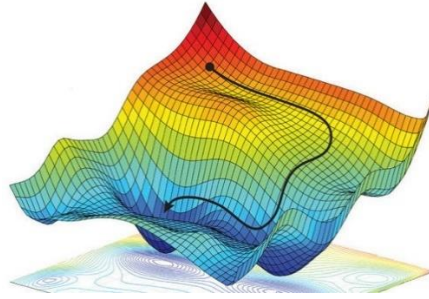

Figure 23 3D visualisation of complex loss landscape. The model must be capable of escaping saddle points and local minima to reach the global optimal solution.

Two optimisation functions were assessed for this task which are robust in escaping local minima:

Stochastic Gradient Descent: Gradient descent approaches operate by means of an iterative descent down a slope to locate a minimum for the loss function, defined as a slope equal to zero. To avoid convergence at local minima, the scale of each adjustment at each step is defined as:

$$\text{Repeated until convergence } \{\omega \leftarrow \omega - \alpha \times \nabla_{\omega} \sum_1^m L_m(\omega)\}$$

Where such a method reduces the step size as the slope approaches zero. Considering this function in the context of a three-dimensional plane, it is evident that there is no mechanism which avoids convergence within a local minimum or saddle point. Hence, an adjustment of this function which leverages a single randomly sampled loss gradient in each step is more appropriate:

$$\text{Repeated until convergence } \{\text{for } i = 1 \dots m \{\omega \leftarrow \omega - \alpha \times \nabla_{\omega} L_m(\omega)\}\}$$

This adjustment avoids convergence at saddle points or local minima as the random sample may point away from a local minimum as it may not lie around this minimum in the loss contour, allowing the model to escape these points, where the summation of all results would not (Netrapalli, 2019; Sclocchi and Wyart, 2023).

Adam Optimisation: Adam is a more sophisticated alternative to the stochastic gradient descent model, which introduces a variable learning rate during training. This method adapts learning rates (\hat{s}) using an exponentially decaying average of past squared gradients and implements an exponentially decaying average of past gradients to update vector direction (\hat{m}):

$$m = \beta_1 m - (1 - \beta_1) \nabla_{\theta} J(\theta)$$

$$s = \beta_2 s + (1 - \beta_2) \nabla_0 J(\theta) \odot \nabla_{\theta} J(\theta)$$

$$\hat{m} = \frac{m}{1 - \beta_1^t}$$

$$\hat{s} = \frac{s}{1 - \beta_2^t}$$

$$\theta = \theta + \eta \hat{m} \oslash \sqrt{\hat{s} + \epsilon}$$

Where \odot and \oslash denote Hadamard (element-wise) product and division respectively and ϵ is a smoothing term to prevent division by zero. Given $\nabla_{\theta} J(\theta) \neq \hat{m}$, the update direction has momentum, which pushes the loss away from local minima to locate the global. The adaptive learning rate, \hat{s} is scaled by such that larger gradients result in smaller learning rates. The consideration the two moving averages of the gradients smooths noise, which is likely to feature prominently in the data under consideration. Such smoothing is particularly effective around saddle points, where gradients approach zero in many dimensions (Kindma and Lei Ba, 2015).

11.2.2 Model Optimisation

To select the optimal model for the task, hyperparameter tuning was carried out in both cases to monitor loss over time and best outcome for the loss functions. Hyperparameters assessed in each case were as follows:

Table 20 Summary of hyperparameters assessed.

Model	Hyperparameter	Values Considered
Stochastic Gradient Descent	Learning rate	0.00001, 0.0001, 0.001, 0.01, 0.05, 0.1, 0.2, 0.3, 0.4, 0.5, 0.6, 0.7
Adam	Learning rate	0.05, 0.1, 0.2, 0.3, 0.4, 0.5, 0.6, 0.7
	Batch sizes	32, 64, 128
	Betas	(0.9, 0.999), (0.8, 0.9), (0.7, 0.8)
	Use regularisations	True, False

A grid search model was employed to iterate through hyperparameters as the task was deemed not to have excessive computational cost to necessitate skipping permutations of hyperparameters. Relatively large learning rates were assessed to explore the solution space more comprehensively and increase convergence rate. Generally larger learning rates are undesirable due to their unstable gradients and tendency to overshoot optimal points, however given the adaptive learning rate in the Adam model, this effect was offset and smooth descent to optimal points were observed. A larger range considering smaller learning rates was considered for the gradient descent given the constant learning rate. The Adam optimiser additionally considered varying β_1 and β_2 which control moving average and second moment decay rate respectively. Varying β_1 aims to find balance between slow

adaptation to mitigate the impacts of noise (smaller β_1 value) and faster adaptation which aids the optimiser where large gradients are present (larger β_1 value). Similarly, β_2 is varied to consider the outcomes where outlier values have reduced impact (smaller β_2 value) and greater response to changes in magnitude (larger β_2 value). Batch size is considered for the purposes of considering the balance between mitigating noise and reaching the true minimum point rather than navigating around it. The approach to batch size ideally would additionally consider over and underfitting more directly, however in this case fit was assessed through the consideration of the data at varying degrees of loss against human-annotated data.

The Adam optimiser yielded better results with smooth loss curves, contrasting the gradient descent model, indicating that the assumption of complexity in the loss landscape was accurate. The Adam model enabled the initial use of a greater learning rate to navigate this, with mechanisms to escape local minima which was not possible in the gradient descent model due to its constant learning rate.

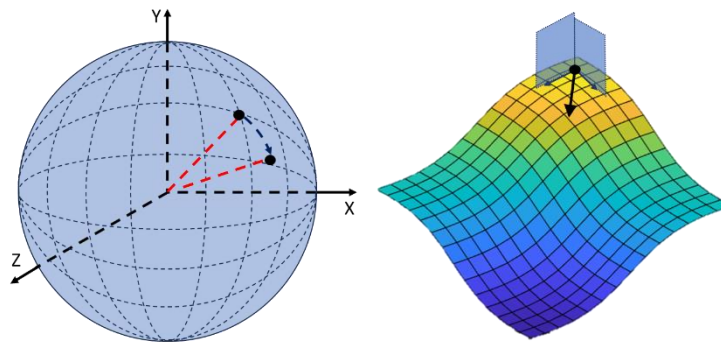

Figure 24 Word vector optimisation step. Adam optimiser dictates step direction and size, while normalisation ensures the result of each step remains on the plane.

11.2.3 Normalisation

To ensure training would not be prematurely halted due to the direction of vector shifts, and reduce impact vector length related noise, after each iteration vectors were normalised to unit length by dividing each vector by its Euclidean norm. The result is each step moves vectors across a spherical plane of radius 1, rather than leaving the movement plane undefined.

This approach preserves cosine similarity values which are not impacted by magnitude, however when considering emotions, it is possible that magnitude may play a role in their identity; for example, it is intuitive that *mad* indicates a less intense emotion than *furious* which should be reflected in their respective vector magnitudes (Taraba, 2020). This information is lost using this approach. However, it

is unclear the degree to which this information may be of value in the context of the comparisons in question.

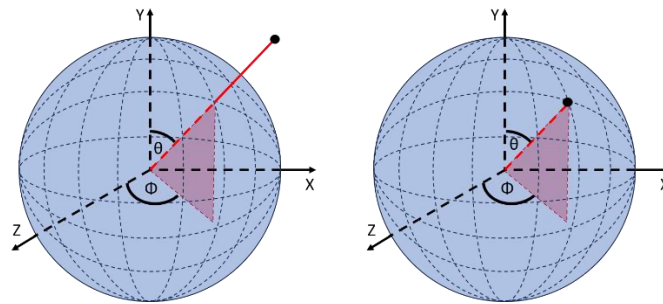

Figure 25 Word vector normalisation process. Each vector is adjusted such that its lies at some point on a 3D spherical plane of radius 1. As angles θ and Φ are conserved in the process, sentiment is largely unaffected and strategies for comparison using cosine similarity are still valid.

11.3 Basic Theory Regression

This section supplements work within the body of the text which outlines a regression model to expand upon parameters for emojis relating to basic theory. This section discusses pre-processing steps such as feature scaling, mitigation of skew in target variables, data preparation for machine learning in addition to model selection optimisation and evaluation.

11.3.1 Feature Scaling

The available data for the task falls into several classes: basic emotions (8 features), dimensional theory polar emotions (2 features), degree of neutrality and sentiment score. This presents a challenge with regards to feature scaling. It is unlikely that a simplistic strategy of scaling evenly across all features will appropriately represent the patterns present thus an alternative strategy was implemented. The four parameter classes were scaled relative to each other using a simplistic min-max scaler. A secondary scaling was applied within the two classes containing multiple features to scale them proportionate to their class. This approach considers that not every emoji evokes equal magnitude of emotion and prevents the disproportionate consideration of one emotional model based on the quantity of features it contains.

11.3.2 Mitigation of Skew in Target Variables

In general machine learning algorithms perform better where data is normally distributed. Significant deviations from this can lead to patterns being learned only for the majority case, leading to bias or poor performance for more rare features. Exploratory analysis for basic theory data highlighted skew in the target variables for the regression. This work aims to propose solutions to improve outcomes of the regression model. Four approaches were evaluated for each basic emotion to address the skew in the data:

Table 21 Strategies evaluated to mitigate skew for each basic emotion.

Transformation	Formula
Log transform	$x \rightarrow \log x$
Square root transformation	$x \rightarrow \sqrt{x}$
Cube root transformation	$x \rightarrow \sqrt[3]{x}$
Reciprocal transformation	$x \rightarrow \frac{1}{x}$

And the degree of improvement was defined by the skewness metric:

$$skewness = \frac{E[(X - \mu)^3]}{\sigma^3}$$

Where E is the expectation operator and X is a random variable and the best identified outcome is that which is closest to zero.

Table 22 Results of skewness transformation.

Basic Emotion	Skew before transformation	Best transformer	Best skew value
Anger	2.21	Reciprocal transformation	-1.18
Anticipation	0.197	Cube root transformation	0.000668
Disgust	1.23	Reciprocal transformation	-0.706
Fear	1.65	Reciprocal transformation	-0.0947
Joy	0.0395	No transformation	0.0395
Sadness	1.96	Reciprocal transformation	-1.17
Surprise	0.638	Reciprocal transformation	-0.0309
Trust	0.377	Log transformation	0.109

Each optimal transformation was performed on the respective data and stored in separate columns. This action was performed as the performance of certain regression models is adversely affected by skew in data. Where these parameters are used to yield outcomes for regression tasks a reverse operation can be performed on predictions to revert the data to its original form.

11.3.3 Assessment of Components for Model Selection for Basic Theory Regression

Data volume: The dataset contains 150 rows for use in the regression task, a small volume of data which will likely limit the model selection to more simplistic options, which perform better on smaller datasets.

Parameters for training: A significant volume of approximations have been generated prior to and following vector adjustments. Given parameters which display greater linear correlation to the target variable will be of greater value to the model, three subsets of appropriations with the greatest

similarity to the target variable will be selected in each case to aid in model training. Based on the same logic, dimensionality reduction during optimisation will also be performed with consideration to similarity.

Target variables: Both target variables with skew mitigated and without transformation will be evaluated and the option which yields the best results will be used. Previous data evaluation which focused on correlation data highlighted that basic emotions sometimes display correlation or negative correlation to the others which indicates that a multivariate regression approach may be viable. Such an approach would account for both the relationship between the target and input parameters in addition to the relationships between each target variable. Traditional univariate regression may provide a more accurate result due to the small data volume limiting the bandwidth to increase complexity thus both options will be considered.

11.4 Model Development for Basic Theory Regression

The overall goal of the model development process was to identify the best possible model for the regression task with regards to its accuracy and robustness. This section discusses in depth the process to supplement work in the body of the text.

11.4.1 Data Split

The data available was split into two subsets of train and test data at a ratio of 80:20. This represents a high-typical split for similar use cases, which was deemed appropriate given the small quantity of data available as it retains as much data as possible for the training set, while ensuring the test subset is of sufficient size to give reliable indications of the models' performance. The purpose of the test data is to withhold some data from the training process to understand how the model performs on unseen data. Within the training process, a secondary data split is performed during cross-validation. These processes were implemented to ensure that recorded performance is attributable to the models' predictive capabilities, rather than the selection of train and test data for a particular instance.

11.4.2 Models Evaluated

The model selection process was created with the purpose of identifying the most optimised and robust model possible for the regression task. Given the limitations in data volume a focus on models with more simplistic architectures was appropriate. The following models were assessed:

Linear Regression: Models the relationship between a dependent variable and one or more independent variables by fitting the parameters to a linear equation. This model is simplistic therefore performs well on smaller volumes of training data. The Pearson's correlation metrics evaluated

previously show moderate to high-moderate correlation between parameters and the target variables which indicates that this model may be appropriate for the task.

Random Forest: Combines multiple decision tree regressors to predict the target variable. This model is similarly simplistic thus appropriate for the small dataset. If generalisation is a challenge, the aggregation of predictions from multiple decision trees can mitigate the impacts of overfitting. Overfitting has been identified as a potential problem given the predictions not displaying total correlation due to the limitations associated with the vector information and approximation methodologies highlighted previously.

XGBoost Regression: An adaptation of the Random Forest regressor which constructs an ensemble of decision trees sequentially, where each tree is modified to correct errors in its predecessor. Predictions are weighted to optimise the overall loss function which enables the capture of more complex patterns than Random Forest, however in this case the increased complexity may be of detriment due to the data volume.

Support Vector Regression: An adaptation of linear regression which defines a hyperplane that best fits the data while minimizing points which fall outside of these boundaries. The model reduces overfitting using a margin of error around the plane where the data can reside, and its simplicity enables the implementation with small datasets.

Gaussian Process Regression: A model which describes probability distributions over many functions to capture uncertainty and use a probabilistic framework for regression. The model works well for limited sample sized, while still capturing more complex, non-linear relationships and mitigating impacts of noise. Uncertainty metrics may additionally be of value in ensuring the final model is suitably robust.

K-Nearest Neighbours Regression: Predicts the value of a target variable by averaging the values of its k closest neighbours. The approach is simplistic and does not rely on large datasets to generate predictions. This is a potentially viable option as throughout the data preparation, an emphasis on generating approximations where similar emotions have similar vectors was implemented, which should return similarity scores which align to similar alternatives. This may not be sufficient given the correlations achieved previously, which may indicate that there is insufficient cohesion between similar emojis to obtain accurate results.

11.4.3 Target Variable Format Selection

The target variables were previously identified to not have a normal distribution and thus alternatives were generated which adjust the values to have a normal distribution. Both these parameters in addition the original labels were assessed to obtain the most optimal outcomes.

The task was identified to have potential for both univariate and multivariate regression. Both options were assessed to ensure comprehensive coverage of consideration to possible optimal models.

11.4.4 Model Optimisation

The optimisation process for the models had two goals. To determine the parameters which generate the most accurate predictions and was robust to altering the data. Hyperparameter tuning was deployed to determine the best possible outcome performance each model was capable of. Cross-validation was implemented to evaluate how robust the performance was.

11.4.5 Hyperparameter Tuning

The hyperparameter grids for each respective model were generated with the goal of assessing the impact of a broad range of hyperparameters on the outcomes of the models. Such hyperparameters were identified in the relevant documentation for each model. The values for each hyperparameter in each case aim to cover a broad range of possible options, spanning a range that covers typical values found in similar implementations in literature, adding a buffer above and below the range for comprehensive assessment. Where the hyperparameter has categorical options, these were selected based upon their potential suitability following assessment against the problem set and data available in cases where the number of options was too large for use.

Given the small data volume, the computational cost of the training processes is reasonably low, even where many hyperparameters are present in the grid. For this reason, the grid search method for tuning was deployed to provide the most comprehensive assessment of the selected hyperparameters, which considers every combination of hyperparameters within the defined grid space.

11.4.6 Cross-Validation

To ensure the model performance is not dependent on the specific combination of train and validation data used in a single instance, a cross validation model was implemented to ensure the optimal identified outcome was robust when predicting unseen data. A k-fold method was used which splits the data into five components and combines them to form k iterations of train and validation data. Five folds was the k-value deemed appropriate as this represents an 80:20 split of training and validation data, which was selected per the logic of the split prior to the training stage.

11.4.7 Dimensionality Reduction

The selection of three sets of prediction parameters was implemented with the goal of each subset being able to mitigate the impacts of their respective limitations. However, this strategy operates upon the assumption that the error is inconsistent across each set of approximations, which may not be the case and results in a large quantity of features being introduced during training. This strategy has a significant potential for underperformance without dimensionality reduction due to overfitting, multicollinearity and increasing complexity with a large quantity of features. Several subsets of data were generated by splitting the data into subsets for each approximation method in addition to selectively excluding features with low correlation to the target parameter, per the Pearson's correlations determined previously.

11.4.8 Model Evaluation

The models were assessed in terms of their performance based on three metrics which work together to provide a broad picture of the performance:

Mean absolute error: Determines the mean absolute difference between predicted and actual values. This metric is selected to provide an easily interpretable metric to understand the error in the predicted values.

Mean squared error: Quantifies the average of the squared differences between predicted and actual values, which provides an indication of the overall magnitude of prediction errors with larger penalties applied to greater errors. Given the mean absolute error provides a mean value which does not provide much information regarding the distribution of the error across each individual prediction, the additional information provided by the mean squared error is of value to supplement this limitation.

R² score: Measures the proportion of variance in the target variable which can be explained by the input parameters and can be considered a measure of the 'goodness of fit' of the model. This metric was included to provide a more comprehensive understanding of the models' performance, such as the models ability to generalise which is also essential to understand when considering model performance.

11.4.9 Neural Network Evaluation

11.4.9.1 Model Selection

Outcomes from model selection using traditional machine learning models found that in multiple cases models capable of learning more complex patterns performed best. To ensure a comprehensive evaluation of models for the task, several neural networks were assessed for univariate regression.

While these models generally require larger volumes of training data to learn patterns, they are also capable of modelling more complex patterns. The assessment was carried out to understand if this trade off yielded a favourable result in this case. The models assessed were as follows:

Feedforward Neural Network: A model which learns patterns by passing data through sequential layers, applying weighted transformations and activation functions.

Convolutional Neural Network: A model which uses convolutional layers to automatically extract relevant features from the input followed by fully connected layers to map the features to the output. It is more commonly used in image processing; however similar implementations have been identified in literature.

Radial Basis Function Neural Network: A model which uses a radial basis function as the activation function in its hidden layer. They excel at approximation and interpolation tasks, making them highly suitable for data which contains complex relationships. Additionally, they are effective using data which is unevenly distributed which may improve outcomes given the non-parametric nature of parameters available.

The neural network models are capable of modelling more complex patterns than the previous models, however with increased complexity there is a necessity for a greater volume of data, which is unavailable for this task. *Anger* was one such emotion which performed best using a more complex model: the Gaussian Process Regressor, therefore this emotion was selected for initial evaluation of the models. Due to increase computational complexity, initial evaluation was carried out for each model with some manual hyperparameter tuning and model with greatest potential (Feedforward Neural Network) was more extensively tuned. This enabled a more extensive tuning process to be carried out with a more comprehensive search of the hyperparameters with the resources available. The initial stage of the process aimed to obtain parameters which resulted in the model of greatest accuracy:

Dense layers: Varying the number of layers present in a neural network generally increases its capacity to learn complex patterns, however as complexity increases, the possibility of overfitting and the quantity of data necessary to obtain meaningful results increases. Models containing between 1 and 6 dense layers were evaluated to find a balance complexity and generalisation. The dense layer units were additionally varied to further optimise this effect. Unit values were varied from 8 to 4096 in steps of 128 units to comprehensively assess the optimal options for each layer in the model.

Dense layers calculate the dot product of the input and a weight matrix, which is transformed via an activation function. Several activation functions were assessed in each layer; ReLU, SELU, elu and

swish. The selection of activation functions centred around methods which restrict negative values as sparse representation can aid in generalisation, which is likely to be a challenge given the limited data. These activations also simplify the optimisation landscape thus decreasing training times which enables a more comprehensive search of other hyperparameters with the available resources (Nguyen *et al.*, 2021). ReLU is one such activation function for many problem sets and returns positive values unchanged and converts negative values to zero:

$$\text{ReLU: } f(x) = \max(0, x)$$

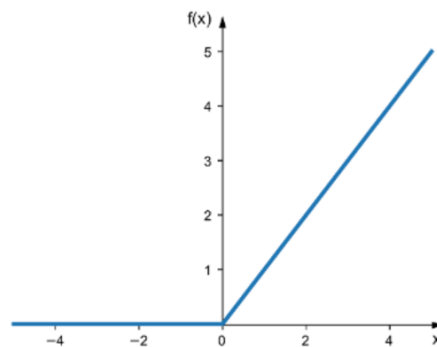

Figure 26 ReLU activation function graph.

The ability to output zero differs from alternatives which can only approximate zero. The result of this feature is a more simplistic model which is desirable in this case due to labelled data availability. However, if the output is consistently zero for all inputs, the neuron becomes inactive and stops contributing to learning. The ELU function operates on a similar principle, adding a constant to smooth negative value:

$$\text{ELU: } f(x) = \begin{cases} x & \text{if } x > 0 \\ \alpha(e^x - 1) & \text{if } x \leq 0 \end{cases}$$

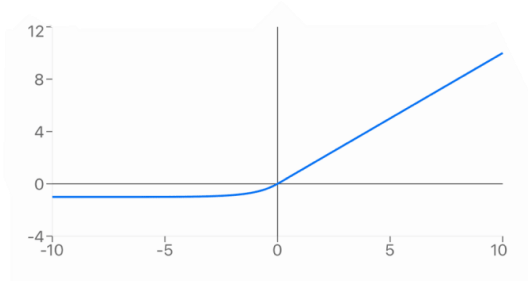

Figure 27 ELU activation function graph.

This is a highly popular adaptation of ReLU which addresses the limitation of inactivity, and generally converges faster, however it is more computationally expensive due to its non-linearity. The SELU function addresses the same limitation using self-normalisation:

$$\text{SELU: } f(x) = \begin{cases} \lambda x & \text{if } x > 0 \\ \lambda \alpha (e^x - 1) & \text{if } x \leq 0 \end{cases}$$

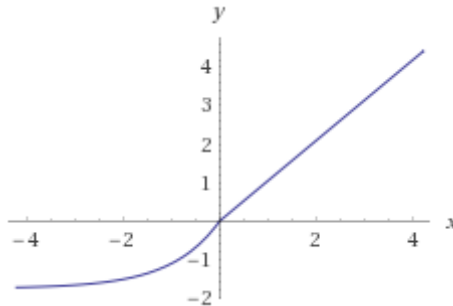

Figure 28 SELU activation function graph.

The normalisation in this function, generally have more stable gradients than ELU activated models, however there is significantly less implementation in literature therefore their advantages and disadvantages may not be comprehensively understood. Finally, the swish activation introduces non-linearity for negative inputs using the sigmoid function:

$$\text{Swish: } f(x) = x \times \sigma(\beta \times x) \text{ where } \sigma = \frac{1}{1+e^{-x}}$$

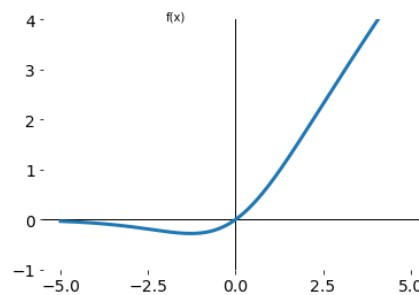

Figure 29 Swish activation function graph.

Such an equation results a non-monotonic first derivative and smoothing. The function has been shown to outperform ReLU however is more computationally expensive due to increased linearity (Ramachandran, Zoph and Quoc, 2017).

Dropout and batch normalisation layers: Initial evaluation of the neural networks displayed a discrepancy between train and test data performance even after convergence, which indicated poor generalisation. Such an observation highlighted the necessity for a robust mechanism to mitigate overfitting. Optional dropout layers were considered between dense layers to prevent overfitting. These layers randomly select a portion of the neurons to deactivate. This differs from the previously

mentioned limitation of the ReLU function as the output layer is scaled in proportion to the dropout rate. Dense layers discourage neurons from becoming too specialised; thus, the neural network must learn more robust features. Dropout rates were varied to ensure optimal outcomes could be obtained from these layers. Batch normalisation was evaluated in a similar manner to the dense layers. During each iteration, these layers normalise the inputs by scaling them to have unit variance, which is performed within each batch of training data. This stabilises the distribution of inputs, encouraging more consistent updates to weights, leading to improved generalisation on unseen data.

Learning rate: Learning rate updates the degree to which weights are updated after each iteration of training. This is a highly influential parameter to model performance thus many potential values were assessed. Excessively large or small learning rates result in premature convergence and a suboptimal outcome or an extremely slow convergence respectively. No exploration of adaptive learning rates was implemented in this case to limit the computational cost of the tuning process; however, this may be an alternative approach where greater computing resources are available.

Efficiency control: Given the large range of parameters to be assessed and the relatively long training times associated with more complex models, measures were implemented to improve efficiency. While these do not directly impact the performance of a model, it allows the tuning process to explore a greater range of hyperparameters, which leads to a greater probability of identifying an optimal outcome. An early stopping callback was implemented to halt model training if the performance did not improve for 5 epochs based on the mean absolute error of the validation data. This is a relatively strict approach; however, this serves to reduce consideration of models with unstable gradients in addition to halting training where the model has stopped improving. The effect of this is that more combinations of hyperparameters (500 trials conducted) can be tested in a reasonable period, and more epochs (300) can be used so models which generate accurate predictions but are inefficient can also be considered. Batch normalisation and the selected activation functions additionally serve to improve convergence rates and by extension overall process efficiency by stabilising inputs.

From the hyperparameter tuning process, three models which displayed the best performance were progressed to cross validation to evaluate their generalisation capabilities further. A 5-fold cross validation was implemented per the logic of the traditional neural networks.

11.4.9.2 Performance Evaluation

The results of this evaluation are detailed in table 23. Even where significant action was taken to ensure good generalisation, the result is an unstable model with poor alignment in metrics across the validation and test data. The error metrics show better performance in the test data, even where the R^2 score is significantly worse. In both cases the R^2 score indicates that the model cannot explain the

patterns in the model thus the true performance should the model be deployed for prediction of unseen data cannot be understood reliably. For this reason, neural networks were excluded from consideration for the regression task.

Table 23 Neural Network performance evaluation results.

Metric	Validation Data Performance	Test Data Performance
Mean Absolute Error	0.0125	0.00670
Mean Squared Error	0.000278	0.000852
R ² Score	0.000393	-0.155

11.5 Dimensional Theory Regression

11.5.1 Selection of Pre-Trained Models

The purpose of this section is to narrow the scope of potential neural network architectures for assessment for a regression task to generate dimensional emotional theory parameters. This task has been broken down into two phases:

Phase 1: Identification of architectures commonly used in relevant literature and critical evaluation of their features with regards to the specific task.

Phase 2: Using the most suitable identified architecture from phase 1, assess several pre-trained models which fall into this category for the regression task.

11.5.2 Evaluation of Architectures in Literature for Sentiment Regression

Sentiment is fundamentally linked to context and thus models which successfully capture sentiment are likely to contain characteristics which enable the capture of long-term dependencies. Neural network architectures are widely utilised for such purposes. Their suitability is largely attributable to aspects of their architecture such as their:

Ability to handle sequential data: As language is sequential in nature, sentiment is often linked to word order. As neural networks handle data sequentially, their outcomes are often improved compared to more simplistic models.

Robustness against noise: Language is inherently noisy and variable due to variance in vernacular across a population in addition to relatively frequent errors in spelling or grammar. Such an effect is known to be more prominent in online content, where such features are sometimes used to add nuance to pragmatics. In the context of a problem set where there is potential for such features to

add insight, this feature of such architectures may possess limitations if this information cannot be extracted in another manner.

Several models which would fall under this category are prominently found throughout literature evaluating sentiment analysis methodologies and specifically in the domain of sarcasm detection due to these features. The three primary models identified were as follows:

LSTM: The LSTM mechanism of selective memory is made up of a cell state, hidden state, and gates. The NN models sequential data by propagating over time through the connection of sequential events using the hidden state. This component captures dependencies by considering both the previous step and current output:

$$\alpha_n = f(W_n, a_{n-1}, x_n)$$

However, a feature of such a mechanism result in all previous steps being considered in the current step when implemented in isolation due to the chain rule:

$$\alpha_n = f(W_n, a_{n-1}, x_n) = f(W_n, f(W_{n-1}, a_{n-2}, x_{n-1}), x_n)$$

Because:

$$\alpha_{n-1} = f(W_n, a_{n-2}, x_n)$$

With the ultimate result being either vanishing or exploding gradients and thus limitations on the abilities to capture long term dependencies in isolation (Jang *et al.*, 2020). The cell state mitigates this effect through the filtering of less relevant information from the memory through the forget gate. This information, in addition to the weights from the input gate enable the model to learn which time steps contain important information, resulting in weights for each time step being represented in proportion to their understood importance to the model. Literature evaluating this architecture is not consistent with regards to its assessment of the efficacy of such a mechanism; with some studies citing the model as effective to capture long-term dependencies, and others postulating that the mechanism may ‘dilute’ important information over time (Jang, Sohn and Lim, 2023). Similar contrasting observations are found in the sentiment across literature with regards to their robustness against noise, with the former asserting that noise information is filtered efficiently during training and the latter arguing the converse and observing amplification of noise. In this context, what is traditionally regarded as noise may provide pragmatic cues with respect to potential sarcasm as discussed above, these cues may be indicative that context of the problem set plays a part in the efficacy of the architecture to model valid patterns in the data, which explains contrasting observations within

literature. No works could be identified which assessed this hypothesis, however this may be an area for future research.

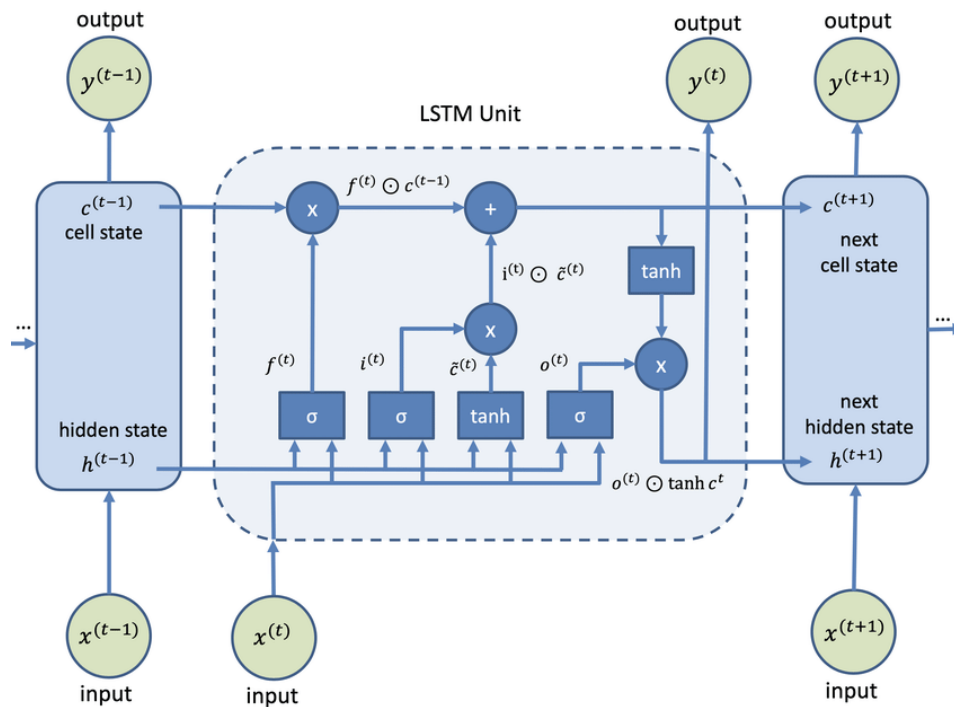

Figure 30 LSTM unit architecture.

GRU: GRU models address vanishing and exploding gradients using a more simplistic mechanism than LSTM. These models omit the cell state and regulate memory using gates. These architectures utilise an update gate to dictate the information which is retained from the previous step in series with a reset gate which dictates the information which should be eliminated (Dey and Salemt, 2017). Compared to LSTMs for natural language processing tasks, due to their more simplistic architecture GRU models seem to perform better where shorter data sequences are used, possibly providing greater potential in the context of the short form content as is used for the problem set in question (Pudikov and Brovko, 2021).

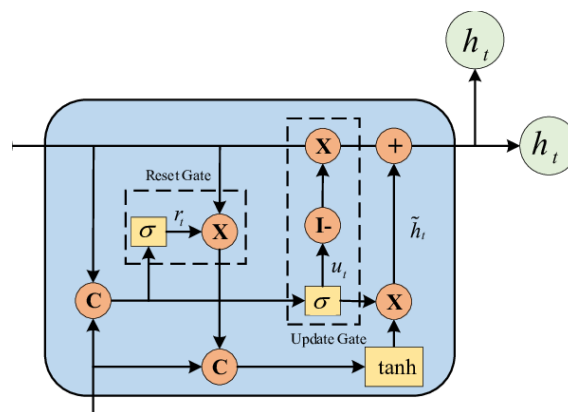

Figure 31 GRU unit architecture.

Present state-of-the-art for sentiment analysis also includes significant volume of models which contain an alternative mechanism for memory. Transformer-based models leverage self-attention mechanisms to capture dependencies of long and short ranges (Potamias, Siolas and Stafylopatis, 2020).

These models are based on encoder-decoder architectures, which are capable of processing data in parallel due to their attention mechanism which avoids processing tokens in parallel in favour of processing token sequences as a single block. The encoder consists of several layers, each containing two sublayers. The first sublayer generates self-attention and the second consists of a fully connected feed-forward network with two linear transformations and activation function (for example, ReLU):

$$FFN(x) = ReLU(W_1x + b_1)W_2 + b_2$$

Where each layer uses its own weights and bias parameters. Given there is no inclusion of recurrence, there is no embedded manner to consider the relative position of words. To address this, positional encodings are added to the word embeddings.

The decoder consists of several layers, which are each composed of three sublayers: the first decodes the previous input to extract positional information and apply attention. The attention in decoders is distinguished from that found in the encoder cells as they do not consider all words, but rather only words which have occurred before the current. The second layer contains a self-attention mechanism which receives information from the previous sublayers of decoders and the encoders output keys and values. The final decoder sublayer consists of a fully connected feed-forward neural network, like that of the second sublayer in the encoder cells.

The attention layers operate by passing each word in the sequence through the embedding and positional encoding layers to generate their respective vectors. The result is passed into the encoder where it is first processed by the attention module. The sequence is passed through three separate layers which each produce a matrix. These layers consist of a query which defines the word for which the attention is to be calculated and key and value are compared to the query with regards to their relevance. These transformations are trainable operations which are adjusted to produce the desired output predictions over the course of training, quantified by the attention score, defined as the dot product between the query matrix and a transpose of the key matrix:

$$Z = Softmax\left(\frac{QK^T}{\sqrt{d_k}}\right)V$$

An intermediate matrix is produced, consisting of a multiplication between all combinations of the words in the respective matrices. A second dot product calculation is performed between the intermediate matrix and the value matrix to produce the attention score (Coelho *et al.*, 2021).

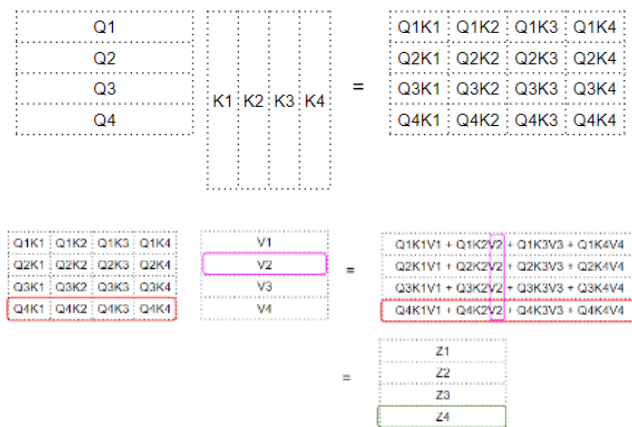

Figure 32 Matrix operations to determine attention scores.

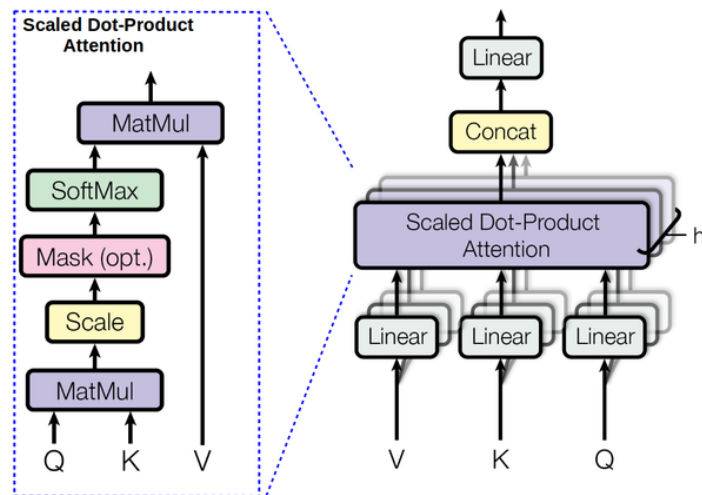

Figure 33 Architecture and mechanism of transformer model attention layers.

Given such a mechanism which learns based on similarities and differences in the input words, the architecture is aligned with the previous methodology for word vector transformation which yielded improved results compared to the original word vectors used in the basic theory regression task. Additionally, the lack of necessity for labelled data is advantageous adaptations of the strategy implemented for the basic theory regression could not yield acceptable levels of accuracy. The key characteristics of the training data which may have contributed to this result may be the small size of the training set, and the potential for complexity in the relationships between the emoji and labels, which could not be captured by less complex algorithms, more appropriate for the available training data. While traditional neural networks necessitate large, labelled datasets, the converse is true for

transformer-based models which learn based on patterns between elements in the dataset, eliminating the need for such a resource intensive annotation process.

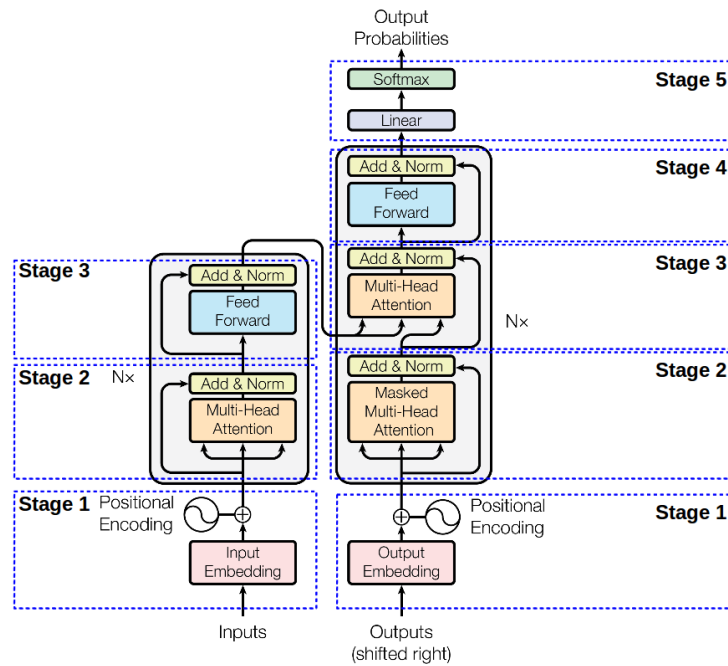

Figure 34 Transformer model architecture.

Each identified option presents advantages and disadvantages with regards to their architecture, and evaluation of each option may be the best approach to determining the best performance in this use case. However, considering the identified neural network options which necessitate annotated data, no models were identified which were trained using emoji and thus these options were omitted from consideration. Transformer-based models for dimensional theory sentiment analysis trained using emoji were identified, falling into the BERT category. Several iterations of BERT models tuned for various contexts to achieve outputs of dimensional-based sentiment scores were evaluated for correlation to the human-annotated dataset using Pearson’s correlation.

11.6 Survey Components

The following section discusses factors of consideration during survey design, construction, and sampling strategies. This section supplements work relating to the primary research component in the body of the text.

11.6.1 Harm and Risk Assessment

When conducting research involving human participation, it is important that the potential for societal benefit is balanced against the risks involved for participants. The purpose of this assessment is to establish the magnitude and probability of any risks or discomforts which may be experienced by the

participants such as harm and privacy so that adequate disclosures can be made to potential participants, ensuring their consent to participate is a fully informed decision.

By nature, sarcastic content contains subject matter and inferences which may cause offence to some, thus psychological harm was deemed a primary potential cause of harm for this work and assessments were focused on mitigating this harm. The dataset for which the tweets are sourced for this survey carried out a screening process to identify and exclude content which may be considered excessively harmful. Given the definition of what was considered excessively harmful was not disclosed, a secondary screening was carried out on the content which would aim to remove content related to the following categories: violence, abuse of animals or humans, crime, terrorism, eating disorders, suicide, pornography, and exploitation of vulnerable populations. Given participants were not limited to Ireland, this list reflects the consensus of multiple English-speaking countries with regards to their legal definitions of what is considered harmful content in the online space (Pillalamarri and Cody, 2021). This screening process did not highlight any content which may be classified as significantly harmful, indicating that the initial screening was effective in addition to the likelihood that participants were unlikely to submit such content, as it could be traced back to them, even if it was stored anonymously in the dataset depending on their privacy settings on Twitter. The screening process was unable to universally remove content relating to these topics as in sarcastic content there are instances which refers to these topics in a manner which has low likelihood for harm. The following examples are taken from the question pool as examples where a harmful subject matter is referenced in a tweet which is deemed low risk of harm:

The only thing I got from college was a caffeine addiction.

I would kill a man for a forehead kiss rn.

Following the assessment, the probability and magnitude of psychological harm to participants was determined to be low.

An additional risk associated with collecting data from participants relates to privacy. It is best practice to collect the minimum necessary personal data and ensure storage and reporting comply with legal requirements and good ethical practices. The nature of the work does not benefit from participants being identifiable to the researcher, or anyone else who may view this work thus to preserve privacy, data was collected anonymously. As there was no data which makes participants directly or indirectly identifiable, this work falls outside the scope of GDPR regulation (EU Parliament, 2016), however governance surrounding participant control over their data is still good practice and thus the option to retroactively manage participation was implemented. This was implemented by prompting each

participant to input a 6-character code, with inbuilt logic to prevent duplication. The participants were informed that should they wish to withdraw consent, they could reach out to the researcher via the provided email address and provide this code to remove their data from the study. This means that data collected falls into a potentially identifiable classification rather than total anonymity, however identification is controlled solely by the participant. Privacy and safeguarding of underage individuals were additionally managed via in-built logic during survey construction. The population was restricted to those over 18, however where a survey is posted on online platforms accessible to those under 18, it was deemed important to add additional measures to ensure data of those under 18 would not be processed. This is addressed in the consent page of the survey which highlights this restriction on participation. A secondary measure involves a question which asks if the participant is over the age of 18. Where the *No* option is selected for this question, the participant will be routed passed the body of the survey to the final page thanking participants for their responses and the response will not be recorded. These measures establish a framework for data collection which affords participants maximum privacy and minimises associated risks through the collection of information in a manner which does not make individuals identifiable, unless they wish to do so.

This assessment establishes that this survey presents minimal risk of harm to participants. Outlined measures mitigate risk for psychological harm from the presented content, while preserving the purpose of the work. Personal data collected is not excessive and the storage and reporting procedures are deemed sufficient to ensure privacy.

11.6.2 Participant Sampling Strategy

The population to be sampled for this survey consists of individuals over 18 years of age who speak English and use emojis. While individuals under 18 present a potentially interesting population for assessment in this problem set due to their high frequency of use of both emojis and social media, there are significant ethical concerns for obtaining data from this population. The Data Protection Act 2018 (ISB, 2018) dictates that data to be collected or processed for those under the age of 16 must be carried out with parental consent. This work expands this limit upwards to the age of 18. Parental consent in the context of a survey distributed via a website link is challenging to verify and therefore cannot be considered sufficient to comply with the law and ethical obligation thus this population must be excluded.

The survey is additionally limited to those who are English speakers, as this is a skill that is required to understand the questions. The final qualification for survey participation is the use of emojis. This is a more challenging qualification to manage, however a question has been added to exclude responses where individuals state that they do not use emoji and responses which have not included a single

emoji in their response were additionally excluded as this may indicate that the individual does not use emojis naturally, or they did not correctly follow the instructions for submission. Basic demographic information was recorded to understand potential skew in data and variance in behaviours across the population.

Based on the target population characteristics sampling must be non-probabilistic in nature, as there are criteria which participants must meet to qualify for participation. To obtain participants of varied age and gender, ideally a quota sampling strategy would be implemented to obtain an even distribution of participants with regards to age and gender. This is difficult while avoiding the use of peers, family, and colleagues as participants which is not good practice due to the potential for bias due to their affiliation to the researcher. To mirror quota sampling as closely as possible, surveys were published in several locations with varying demographics of visitors.

11.6.3 Sourcing Participants

Participants were sourced using a variety of methods, with a stipulation that no participant should have a close personal relationship with the researcher to avoid bias. Participants were obtained via online forums (e.g. r/SampleSize on Reddit), chat groups containing other course students etc. Selected platforms aimed to ensure a sample which was not skewed towards a particular age or gender. Any platform where the primary visitor is under 18 was excluded.

11.6.4 Survey Questions

The survey questions can be broken down into several categories: Consent, qualification, demographic, classification, and emoji-usage questions.

Consent: The purposes of these questions are to establish the participant consenting and eligible to participate in the survey. Valid consent involves potential participants fully understanding the purpose of the survey, the data which will be collected and how it will be used and stored, and any risks associated with their participation. It is also important that there is a clear statement to ensure participants are aligned with the target population. To achieve this anywhere the link for the survey was shared, the following text was added before the link:

Hello, I am searching for participants to complete a survey for me! The purpose of this survey is to gather data about how emojis are used in sarcastic content online, and how this differs from non-sarcastic content. The data will be used in part to develop a model for sarcasm detection. The results will form part of my dissertation to be submitted in partial fulfilment of the requirements of the degree 'MSc in Data Analytics'. Your responses will not be identifiable to you. I am looking for participants 18

or older who speak English and use emojis. If you have any more questions, feel free to reach out to me for help via my email sba22224@student.cct.ie. Thank you in advance!

The landing page of the survey contains all relevant information for participation in greater detail. The page contains a consent clause at the bottom stating that the participant has read and understood the content and is happy to participate in the survey. The survey landing page reads as follows:

Thank you for taking the time to complete this survey! The purpose of this survey is to gather data about how emojis are used in sarcastic content online, and how this differs from non-sarcastic content. The data will be used in part to develop a model for sarcasm detection. The results will form part of my dissertation to be submitted in partial fulfilment of the requirements of the degree 'MSc in Data Analytics'.

Are there any requirements to participate?

Yes. You must be 18 years or older to participate. You must be an English speaker who uses emojis. If this does not describe you, please do not submit a response.

What will I be asked?

You will be asked basic questions about your demographics, and to provide information about how you use emojis in online communication. As you may need to use emojis in some of your answers, this survey is easiest to complete on a mobile device, however for computers there is an emoji keyboard available within the survey!

How is my data stored and managed?

All responses are anonymous. However, if for any reason after submitting your response you would like to withdraw your data from consideration in this work this is possible. On the next page of this survey, you will be prompted to generate a 6-character code which can be used to manage your participation in this survey by reaching out to myself (email is below). You are also welcome to contact me with questions without quoting this code if you have any questions. Data will be accessible by myself and any academic faculty who may require access (for supervision and/or grading of the work).

How can I reach out?

If you have any questions about this work, or how your data will be used, feel free to reach out to me through my student email: sba22224@student.cct.ie.

I have read and understand the above content and I am happy to proceed:

Yes/No (Single-select radio buttons)

Qualification questions: Once consent has been obtained, the participant is routed to questions to verify they fall within the target population for the survey. Each of these questions are mandatory to ensure that prevent events where someone is not identified as ineligible by not providing a response to the disqualifying question. These questions are as follows:

Table 24 Survey questions to verify participant eligibility.

Prompt	Response options and format	Embedded logic
Qualifying Questions These questions make sure you are within the target population for my survey.	Static text field No response required	
Create a 6-digit ID code. This can be letters or numbers (e.g. AB1234). You can use this to reach out regarding the use of your data.	Free text box Mandatory field	No duplicated responses allowed. Response must be exactly six digits. Alpha-numeric characters only
Are you over 18 years of age?	Yes/No Single select radio buttons Mandatory field	Where 'No' is selected, the participant is routed out of the survey to the end thank you message. No data is retained.
Do you use emojis?	Yes/No Single select radio buttons Mandatory field	Where 'No' is selected, the participant is routed out of the survey to the end thank you message.

The goal of the strict formatting and logic is to minimise data cleaning necessary to remove invalid responses and avoid the collection of data from underage individuals.

Demographic questions: The next section establishes basic demographic information about the participants. These questions aim to ensure the data is not disproportionately representative of certain subsets of the population. It is important to establish this information as communication style differs based on background, and conclusions drawn from any subsequent work can only be associated with populations which have been assessed in the research. Future research may expand upon these features as a manner to improve upon sarcasm detection, accounting for your demographic information, background, or interests to make more individualised assessments however this is

outside the scope of this work and significant privacy and ethical considerations may arise as the quantity of personal information collected increases. The questions in this section are as follows:

Table 25 Survey questions to establish demographics of participants.

Prompt	Response Options and Format	Embedded Logic
Demographics This section will ask you basic demographic questions about yourself. The purpose of these questions is to determine the role (if any) that your background may play in how you use emojis, and the way you express sarcasm.	Static text field No response required	
What is your gender?	Male/ Female/ I don't want to say/ Other Single select radio buttons Mandatory field	Other option enables an optional free text field to input custom response
What age are you?	18-24/ 25-34 / 35-44/ 45-64/ 65+/ I don't want to say Single select radio buttons Mandatory field	

These questions are constructed in a manner which ensures every eligible participant can provide an accurate response which is most applicable to them or provide no information for a given question. The goal in this case is to prevent discomfort of the candidates and gain responses which are as accurate as possible.

Classification and emoji use questions: The body of the survey consists of questions aimed to understand how individuals use emojis in sarcastic and non-sarcastic content. There are two primary question types within this section; classification questions which prompt the participant to classify a string of text as sarcastic or non-sarcastic and emoji usage questions which aim to understand how the participant would use emojis when they believe the content is sarcastic or non-sarcastic. These questions appear in pairs where they are related to the same string of text. These questions are repeated 10 times for each participant. The questions in this section are as follows:

Table 26 Survey questions about emoji usage.

Prompt	Response Options and Format	Embedded Logic
<p>Emoji Usage</p> <p>In the next section you will be presented with a number of tweets. For each tweet you will be asked to decide if you think it is sarcastic or not and then fill in the emojis you would use in the tweet, if any. There will be 10 tweets in total. If you feel any of the tweets do not apply to you, you can skip them.</p>	<p>Static text field</p> <p>No response required</p>	
<p>What is sarcasm?</p>	<p>Free text field</p> <p>Mandatory field</p>	
<p>Text string appears at the top of the prompt.</p> <p>What is true about this tweet?</p>	<p>It is sarcastic/ It is not sarcastic/ I don't know</p> <p>Single select radio buttons</p> <p>Optional field</p>	
<p>What emojis (if any) would you add to this tweet?</p> <p>Edit the below text to add the emojis you would use.</p>	<p>Free text field</p> <p>Optional field</p>	<p>Default value is identical to the string in the previous classification question</p>
<p>Do you have any comments you would like to make?</p>	<p>Free text field</p> <p>Optional field</p>	

The first question additionally serves to monitor the quality of responses. Where the response indicates a lack of understanding of what sarcasm is, the quality of the response can be assessed with increased scrutiny. The prompt selection for the paired usage questions varied between participants to obtain a more comprehensive understanding of how sarcasm is conveyed in different contexts. The prompts for each pair of questions were selected from subsets obtained from the iSarcasm dataset of sarcastic and non-sarcastic tweets which contained no emojis.

The sampling strategy can be summarised as follows:

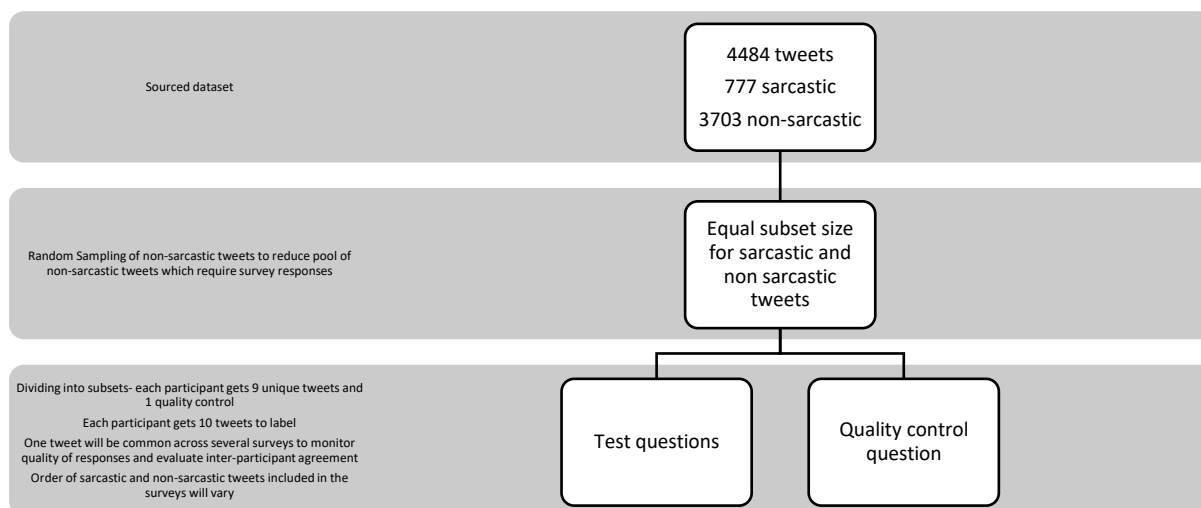

Figure 35 Outline of sampling for emoji usage survey questions.

Sampling of questions is broken down into several stages for this survey, with a goal of ensuring that bias due to question ordering, sampling or decision fatigue are avoided. Quality control questions were randomly selected from both sarcastic and non-sarcastic subsets. These questions were changed intermittently while the survey was live to ensure that a question which results in unrepresentative behaviour was selected for the duration of the work. For each survey, the remaining questions were randomly sampled from the two subsets to yield a 1:1 ratio of sarcastic to non-sarcastic tweets, accounting for the label for the quality control question. This sampling method aims to ensure that each participant is likely to encounter tweets that they will classify as sarcastic *and* non-sarcastic while completing the exercise. The annotations from the original dataset are considered the ‘correct’ response as context is vital to the classification and the context two individuals project onto the same text may lead them to contradictory, yet both valid conclusions. They instead serve as speculative assignments which hope to ensure that there is a likelihood that both classifications will be utilised in each survey. The pattern of appearance of the speculative sarcastic and non-sarcastic prompts distributed at random throughout the survey. In all cases, sampling is performed prior to the initialisation of the survey and is independent of any information about the participant to avoid bias in the questions presented to each participant.

Closing window: Finally, the survey is routed to a thank you screen which thanks the individual for their participation and displays the researchers email address again for any questions the respondent may have.

11.6.5 Survey Design

The survey design was constructed in a manner which aimed to promote optimal outcomes with regards to response rate, homogeneity of data between participants and response quality. The

JotForm platform was selected as the survey builder tool based upon its broad range of conditional formatting options and end-user friendly interface which is compatible across computer and mobile devices. Where a survey appears visually appealing and the interface is easy to use, participants are more likely to complete their responses thus this was an important consideration.

The selection of question formatting was considered based on the requirements of the question, with an overall goal of making the response as simple as possible, with preference to options which increase homogeneity between responses. Single select radio buttons were determined to be the optimal approach to collect data which falls into discrete classes given their simplicity of use for participants and high uniformity between responses. Free text fields were appropriate in some cases, however where possible conditional formatting was used to ensure the user input abided by the instructions.

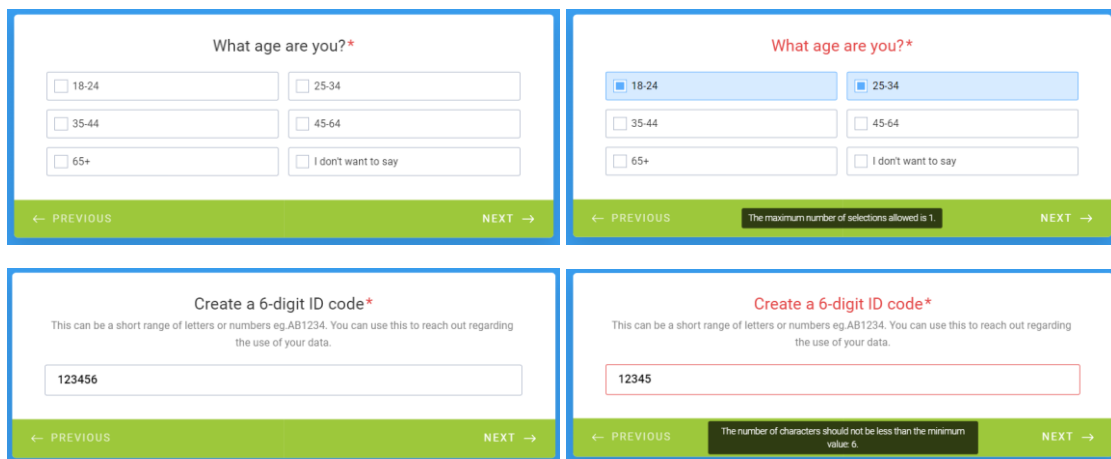

Figure 36 Single select radio buttons to collect discrete data. In built logic ensures that responses yield valid output using prompts to ensure only one option can be selected. Text fields may also contain conditional formatting to ensure instructions are followed.

The question type which requires the most effort to complete for participants is that which prompts them to insert emojis into the prompt tweets. As response quality is likely to decrease with increasing effort requirements, this has been formatted to reduce the work requirement as much as possible:

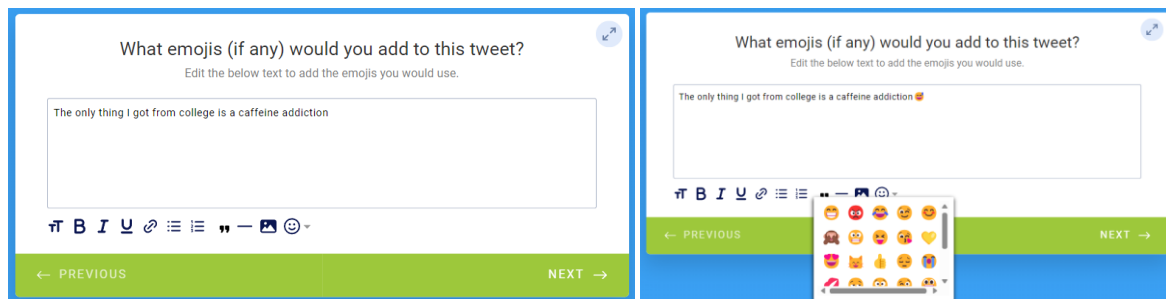

Figure 37 Free text field for emoji use questions is populated with a default value of the text string the participant has previously classified as sarcastic or non-sarcastic to improve response quality. This enables the participant to insert emojis with ease into the text prompt. The figure displays the desktop version of the survey which features a drop-down menu containing emojis to make responses easier where an emoji keyboard is not available.

11.7 Statistical Tests Used

11.7.1 Selection Methodology

Statistical tests serve to provide insights as to whether the characteristic under evaluation influences the population or if two groups are different to one another. The correct selection of statistical test is essential to obtain results which are accurate and reliable. This selection is performed based on characteristics of the underlying data. A primary criterion for selection is the determination of whether data is parametric or non-parametric (Nafii, Bouezmarni and Mesfioui, 2023), which can be determined through the assessment of data with regards to the assumptions made about its distribution:

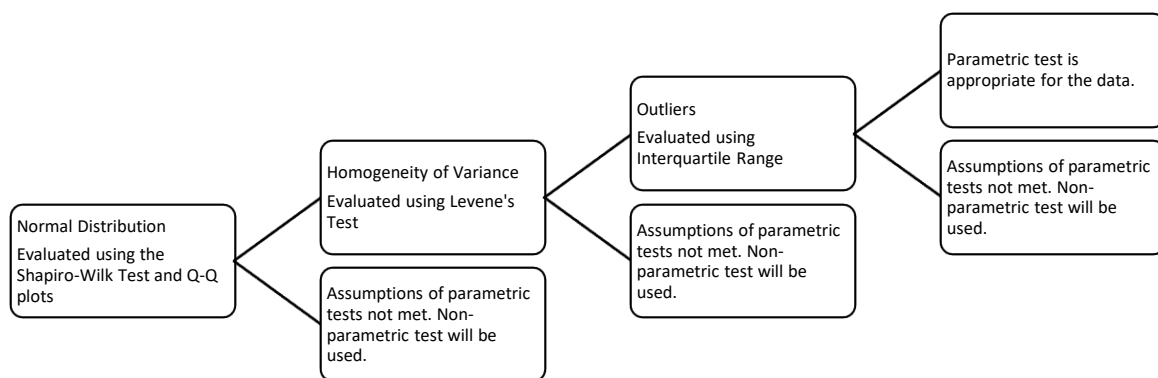

Figure 38 Process flow chart to determine if data under evaluation is parametric or non-parametric.

An additional assumption made for parametric tests are that the observations in each group are independent of observations in every other group. Given survey questions were randomly sampled for inclusion, this assumption is met in all cases.

Where the nature of the data distribution has been determined, the secondary consideration is the relationship between the data to be evaluated. The quantity of groups to be compared, and the dependence or independence of the data must be understood to identify the most appropriate test. Independent data are data sets which are not in any way influenced by each other, and the converse is true for dependent data.

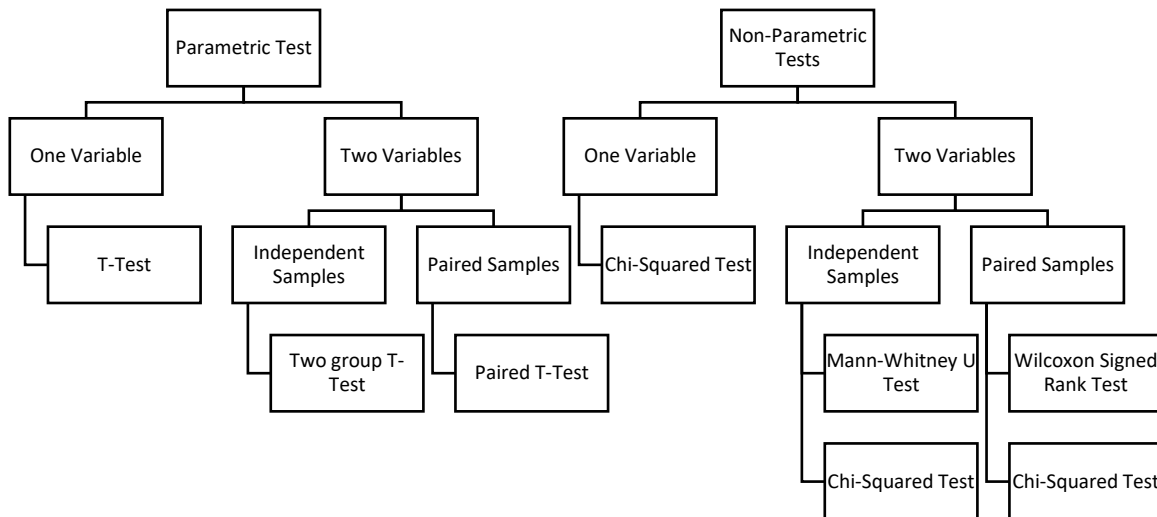

Figure 39 Selection of Statistical Tests.

11.7.2 Statistical Tests Used

Shapiro-Wilk Test: The purpose of the Shapiro-Wilk test is to determine if the data under evaluation is normally distributed. The test computes the test statistic, W , which is based on the correlation between the observed data distribution and the assumed normal distribution where a greater value implies greater correlation. The test defines the null hypothesis as the assumption that the data is normally distributed. The test requires data to be independent, continuous, have at least three observations, no significant skew, and no outliers. This test provides a simple initial evaluation for normality, however as a one-tailed test, it may result in false positive outcomes in some cases. Where a positive result is obtained, to ensure accuracy of the result a Q-Q plot will be used to confirm or reject the result (Villasenor Alva and Estrada, 2009).

Q-Q plot: The Q-Q plot is a qualitative method to evaluate normality in data distribution which plots the quantiles of the data against that a normal distribution. Where the distribution is normal the result is data which aligns with the identity line $x=y$, implying a linear relationship and thus normal distribution of the data.

Levene's Test: Levene's test (Gastwirth, Gel and Miao, 2009) assess the equality of variance of a parameter between groups. This is achieved by comparing the absolute difference between each value and the respective mean and performs an ANOVA test on the resulting differences. The null hypothesis is defined by an assumption of homoscedasticity. The test requires that data is independent and numeric.

Outliers: Interquartile range is a measure of the spread of the central 50% of values in a dataset. In this case outliers were defined as values which fell outside of the range of:

$$Q1 - 1.5 \times IQR < x < Q3 + 1.5 \times IQR$$

Which represents values greater than 2.025 standard deviations from the mean, where approximately 4% of data resides given Gaussian distribution.

11.8 Pragmatic Features Evaluated

This section outlines parameters evaluated to identify potential differences between sarcastic and non-sarcastic text.

Frequency and position of emojis in text: These parameters were assessed as potential structural features that may be indicative of sarcasm. Frequency of emoji use was defined by the average number of emojis per text string. Emoji position was defined as a value within range 0 to 1, indicating the relative location of the emoji to the other characters within the string.

Sentiment Score Features: Sentiment score was evaluated across all previously defined metrics for both basic dimensional emotion models. A comprehensive approach was used to ensure any possible factors which may have relevance to the problem set could be identified. Reported figures for each feature represent the average across each value for the given subset; such an approach has limitations given this is averaging values which may be generated from prompts of opposing sentiment. Where the distribution of positive and negative content is even between the subsets any potential insights may cancel out observed effects. Secondary reporting displays the same metrics, distinguished by their overall polar classification to reduce this impact.

Sentiment Skew: Compares the relative positivity and negativity of emojis found in the text, with the purpose of understanding if either sentiment is disproportionately represented in either subset. This was evaluated by means of comparison the set of positivity and negativity scores for the set emojis in the tweets. This may aid in the determination of whether emojis used in sarcastic data are more frequently positive or negative, and if this differs where other variables are considered.

Sentiment Congruence: Aims to evaluate the alignment of sentiment between the emojis and text within a given text prompt. The metrics reported compare the sentiment of the text at the sentence level to the emoji sentiment and incongruence is defined as the difference between these values. Reported values are averages across the subsets for these values.

Text based markers: Instances of defined text features were defined by the count of the given feature in the prompt. Average quantities per text prompt were the reportable values. Markers evaluated were defined for this task as follows:

- Hashtags: Words or phrases preceded by the # symbol.

- Laughter indicators: Words starting with 'haha' or 'LOL'. The quantity of o's in LOL can vary to identify as many iterations as possible with the same intended meaning. Search was case insensitive to ensure as many instances as possible could be identified. Given these markers add insight to the intended tone, evaluation of their relative representation across subsets may provide value.
- Capitalised words: Words which begin with an upper-case letter. Given postulations that good punctuation practices are not as important in sarcastic content, this may provide a structural indicator for potentially sarcastic content.
- User mentions: Words or phrases starting with the @ symbol.
- Pragmatically relevant punctuation: Aims to identify and punctuation which indicates tone or intent of a given text for example which may be of value in identifying sarcastic text. The punctuation marks defined as relevant were '!', '?' and '...'.
- Affirmatives: Words which imply agreement to a given message.
- Negations: Words which contradict or deny the associated topic or idea.
- Intensifiers: Words which add emphasis to the associated topic or idea.
- Interjections: Words used to interrupt the flow of the speech or text.
- Mid-word capitalisations: Words where capital letters are found in any position after the first. This includes screaming, where entire words are capitalised and interval capitalisation within words, both structures are employed to add insight to the intended tone of the message.

11.9 Topic Modelling Process

Topic modelling was carried out to supplement quantitative feature-based analysis approaches to identify topics or themes in the dataset corpus. As the quantitative statistical analysis carried out is limited by the scope to represent the features numerically, nuances are likely to be overlooked. Topic modelling may provide a deeper comprehension of the underlying pragmatics which characterise sarcastic text. Such a task has several challenges in the context of the problem set in question; the short form nature of Tweets limits the available context, additionally sarcasm detection applies across a broad range of subject matters and the dataset for modelling reflects this. This makes the task of generating coherent topics which can generate insight to the problem set more challenging to obtain.

11.9.1 Data Preparation

The capacity of topic modelling methods to generate coherent insights into the corpus is limited by the quality of the data it is trained on. Where noise is removed and words are grouped based on their root, greater coherence can be achieved in the training process. To achieve the best outcomes the following steps were taken:

User Mentions and URLs: User mentions and URLs were removed from the text as these features do not generally represent useful information in the context of their text only. While insights may be gleaned from alternative information such as the relationship between the author and the account referenced, or the content of link within the URL, this falls outside the scope of topic modelling and thus is regarded as noise.

Spelling: Where words are misspelled, the information the intended word provides to the model is lost, resulting in increased noise and loss of potential important information. Work conducted prior to the topic modelling process indicates that good grammar and punctuation practices are less prominent in sarcastic text compared to non-sarcastic counterparts which is also the case for informal content such as social media posts more broadly, thus it is reasonable to assume that there may be spelling errors in the dataset. A spelling check was applied to the text to correct misspelled words to reduce noise from the dataset and enable the consideration of misspelled words in the topic modelling process.

Contractions and slang: Linguistic devices such as contractions and slang provide valuable information pertaining to pragmatics, however given their high variability between individuals, their high representation in the corpus may be of detriment for topic modelling. For this reason, dictionaries which map these words to their more formalised meanings. It should be noted that for a final sarcasm detection model, the consideration of the slang terms in the form which was found in the original text may be of greater value to understanding relevant patterns, provided their vector forms can be found in the embedding, however for this use case, the conversion was implemented to reduce granularity of the corpus to provide more coherent topics.

Punctuation: Punctuation was removed as it does not provide useful information for the purposes of topic modelling. Where the feature does not provide data which can be used to improve pattern understanding, it instead increases noise. For this reason, punctuation was removed from the data.

Stopwords: Stopwords can be defined as words which do not provide any information to determine the underlying message within language. These words cannot provide information useful for topic modelling therefore they were removed from the text.

N-grams: N-grams are continuous sequences of words within a document. They aim to capture insights from phrases through the retention of context, which is obtained from specific word combinations, rather than individual words only which can be of benefit to topic modelling. Due to the relatively small average word count for each text string, the evaluation of n-grams was limited to bigrams (n=2) and trigrams (n=3). The model was trained using a variety of combinations of n-gram

configurations to determine the optimal approach. Omission of n-grams was additionally considered as they possess notable limitations with regards to sparsity within the dataset. During manual evaluation of text prompts to filter potential harmful content, an additional observation was the variety of topics discussed within the dataset. This observation leads to several assumptions about the output of topics; the topics are likely to be more generalised than specific and the corpus will have few frequently occurring n-grams. This conclusion implies that this pre-processing step may not be optimal, however quantitative evaluation provides greater reliability thus an assessment of their outcomes will be conducted.

Stemming and Lemmatisation: Stemming and lemmatisation refer to text normalisation processes which identify canonical representations for a set of related words where the former is a more simplistic process which reduces words to pseudo-stems while the latter considers context to return linguistically valid outputs known as lemma. These distinctions yield different outcomes in certain use cases:

- Lemmatisation of the word *caring* returns *care* given it accounts for word meaning, however the more simplistic approach of stemming does not and outputs *car*, which is erroneous.
- Lemmatisation with an input of *stripes* will return *strip* for a verb and *stripe* for a noun, whereas stemming cannot discriminate based on part of speech tag thus always returns *strip*.
- In some cases, outputs are the same for example both models return *run* for an input of *running*, however stemming will return output more efficiently due to its more simplistic approach.

As the corpus is not excessively large, computational cost is not a significant factor for consideration, compared to performance. The goal of the process is to reduce granularity between words which provide the same meaning to improve topic comprehension, however it is difficult to assess the extent to which this is valuable before the smoothing effect is too great to generate topics which provide the most optimal topic outcomes. Given a case where lemmatisation returns *good* given an input of *better*, there is some contextual information lost. However, stemming returns the word unchanged preserving this context. Given the advantages and limitations of each option, the model output was assessed using, one, both or none of these options.

Transformation order: The order in which the outlined preprocessing steps are conducted has an impact on the outcomes of the work. The order selected was based on the consideration to the impact they make have on other steps. For example, where a spellcheck is performed prior to mapping slang and contractions to their equivalents, the mapping is likely to identify a greater number of instances

to be mapped, making this a preferable configuration. Where the optimal order is more ambiguous, an iterative approach was implemented to determine the best sequence.

11.9.2 Models Assessed

Given the goal of the model to identify topics which can broadly describe prominent themes for a given set of text inputs, the use of labels is counterproductive to the purpose of the task thus unsupervised learning methods are appropriate for this task. The text is known to have relatively short word length and have a vast range of topics when viewed manually. The dataset is populated with a significant proportion of sarcastic content at this point which is known to have many ‘layers’ to the topics it contains.

LDA model: A probabilistic generative model which explains observations based on their co-occurrence patterns. The model is popular due to its simplicity of implementation and interpretability. However generally underperforms on shorter text and smaller corpora. Additionally, as it assumes document exchangeability, evolution of topics over time cannot be accounted for which would be problematic in the context of any application of a detection pipeline which uses the model over extended periods as online content evolves rapidly. Several instances of this model have been identified for broad subject matters using Twitter content, therefore the model was assessed for this task (Qomariyah, Iriawan and Fithriasari, 2019).

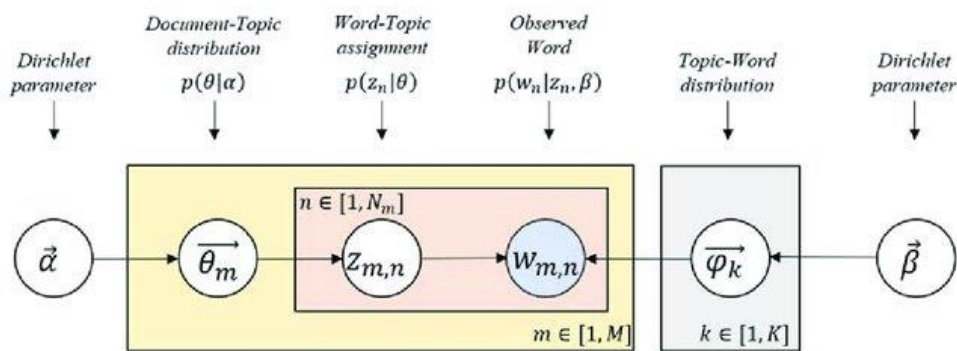

Figure 40 Architecture of LDA model.

NMF model: A model which learns topics by decomposing highly dimensional vectors into non-negative matrices of fewer dimensions representing the topics and their respective weights. The process of non-negative matrix factorisation breaks down a matrix into two:

$$X \approx WH$$

Where the matrices W and H are composed of k and m rows respectively:

$$X = \begin{bmatrix} x_1 \\ x_2 \\ \dots \\ x_k \end{bmatrix} \quad W = \begin{bmatrix} w_1 \\ w_2 \\ \dots \\ w_k \end{bmatrix} \quad H = \begin{bmatrix} h_1 \\ h_2 \\ \dots \\ h_k \end{bmatrix}$$

Based upon the factorised matrices, x_i , the weighted sum of a set of components can be determined, given the rows in H are components and rows in W are their weights:

$$x_i = [w_{i1}, w_{i2}, \dots, w_{ik}] \times \begin{bmatrix} h_1 \\ h_2 \\ \dots \\ h_k \end{bmatrix} = \sum_{j=1}^k w_{ij} \times h_j$$

The restriction of the components for consideration to non-negative weights facilitates a unique manner to identify topics; decomposition of the document-term matrix (where columns represent documents and rows represent weights) yields topics, which can be streamlined using the weighted sum function. Such a method would not be possible where negative weights are permissible, as a negative topic is uninterpretable. The architecture of the NMF model addresses sparsity and noise directly through the decomposition of the document term matrix into a document-topic and topic-term matrices, representing the distribution of topics and terms in each document respectively making it particularly effective for short text (Egger and Yu, 2022).

11.9.3 Model Selection and Evaluation

To ensure the best outcome was identified, both models were compared in their optimised forms. Given the challenges associated with obtaining insightful results in this context, a comprehensive approach to model selection was necessary.

To optimise each model, hyperparameter tuning in combination with optimisation of pre-processing steps was carried out iteratively to obtain the optimal result. Hyperparameter tuning utilised a grid search approach as it provided the most comprehensive assessment of hyperparameter within the grid. Hyperparameters assessed in each case were as follows:

Number of Topics: Topic numbers were evaluated across all four tests carried out, with the goal of obtaining a value which yielded the most optimal outcome across each of the tests. The number of topics was kept constant across each test to aid in judgement-based comparison work. The range for assessed topics was low as this is preferable in short text due to the difficulties in generating more granular topics where data is sparse and noisy.

Passes: The number of passes control the number of times the model processes the corpus. This value must be balanced such that it is sufficiently large to learn and refine the topics in the corpus, however the increase in performance is not indefinite; too many passes lead to overfitting. The values were

varied from small to relatively large, as the data has a broad range of topics based on assessments during survey data screening for harmful content. This indicates that the results of the modelling may be broad and conceptual, therefore the data is particularly susceptible to overfitting. However, the benefits of granularity are also of value to consider, given the process is not excessively computationally expensive.

Chunk Size: Chunk size determines the number of documents that are processed together during analysis. With increasing chunk size, processing time decreases however this also may reduce generalisation abilities. Smaller chunk sizes were therefore represented in greater proportions in the hyperparameter tuning landscape based upon this effect, however larger chunk sizes were also assessed to ensure a comprehensive approach to tuning.

Alpha: This hyperparameter was varied during the NMF model tuning process to adjust the impact of the regularisation parameter. Specifically, this hyperparameter controls the sparsity of the basis matrix. Where the selected alpha value is too low, poor generalisation is observed and the converse is true where an excessively large value is selected.

Beta Loss: Beta loss is a regularisation parameter which controls the sparsity of the coefficient matrix. This operates alongside the alpha hyperparameter in the objective function. The objective function consists of reconstruction error and regularisation terms. The regularisation term is proportional to the Frobenius norm of the factor matrices raised to the power of beta for the coefficient matrix.

Solver: This parameter controls the minimisation of the objective function during the factorisation process within NMF modelling. The assessed options were a multiplicative update and coordinate descent solvers. The former is generally suitable for data with more topics and it more robust to noise. The latter is generally suitable for data with fewer topics, however, is more sensitive to noise. Given the characteristics of the data overlaps with optimal options for each solver to some extent, both options were evaluated during tuning.

L1 ratio: This parameter controls the ratio of L1 and L2 regularisation in the factorisation process. Regularisation in the NMF model consists of two terms; L1 which encourages sparsity in the factorisation process by promoting some of the coefficients to be zero and L2 which acts to oppose this effect by encouraging small values for all coefficients. The two regularisation terms must be balanced to obtain the optimal point which minimises over and underfitting.

Optimal models in each case were assessed using only one quantitative metric, *c_v* coherence which is calculated using a sliding window, a one-set segmentation of top words and an indirect confirmation measure which uses normalised pointwise mutual information and cosine similarity:

$$\vec{v}(W') = \left\{ \sum_{w_i \in W'} NMPI(w_i, w_j)^y \right\}_{j=1, \dots, |W|}$$

$$NMPI(w_i, w_j)^y = \left(\frac{\log \frac{P(w_i, w_j) + \epsilon}{P(w_i) \times P(w_j)}}{-\log(P(w_i, w_j) + \epsilon)} \right)^y$$

$$\phi_{S_i}(\vec{u}, \vec{w}) = \frac{\sum_{i=1}^{|W|} u_i \times w_i}{\|\vec{u}\|_2 \times \|\vec{w}\|_2}$$

Where the coherence score represents the arithmetic mean of these similarities. The score effectively identifies topics that are coherent and interpretable however it does not in all cases correlate well to human judgement. Given the nature of topic modelling, quantitative metrics cannot provide an output which considers the entire picture of the performance as they lack capacity to assess coherence with the degree of nuance of human judgement. For this reason, a series of quantitatively high performing models were identified, and a judgement-based assessment was carried out to characterise the interpretability and relevance of the topics generated. The combination of these two methods aims to offset bias associated with human judgement while still benefiting from the greater ability of human linguistic interpretation to assess such topics compared to quantitative metrics. Finally models with the greatest performance were subjected to a final quality assessment where a random sample of text where the topic was determined to be the dominant feature were generated and judgement was applied to assess their relevance to the respective topics.

11.9.4 Results

Based on quantitative coherence metrics, the NMF model was found to outperform the LDA model for both the overall dataset and the sarcastic only subset. Given the improved capacity of NMF models to perform with shorter text strings, this result is in line with intuition and can be attributed directly to the greater suitability of the NMF model architecture to handle short text. Assessment of the topics based on judgement between the two models yielded a contrasting outcome. While both models generated topics which were generally conceptual, the LDA model yielded outcomes which were easier to interpret. Notably the differences between the topics generated for the entire dataset and the sarcastic subset were explainable in the case of the LDA model, however this was not the case for the NMF model where topics were harder to interpret and had fewer distinctions between the two subsets. Where an analysis of a sample of text prompts compared to their dominant topic was carried out, there was significantly greater alignment in the case of the LDA model based on human judgement. Assessment of a random sample of documents most aligned with each topic corroborated

observations that topics generated by the LDA models generated greater insight than those obtained from the NMF model making it the optimal model for the task.

Table 27 Summary of results from topic modelling for best models.

Top Words for Topic	Interpretation
LDA Model- All Tweets (Coherence Score=0.604)	
Like, Love, Year, Get, Tri, Make, Old, Let, Also, Think	Expression of Preference
Name, Want, Would, Life, Answer, Miss, Come, You, Jazz, Anyway	Reflection or Contemplation of Past Events
Get, Time, Look, Can't, See, Account, Wait, Show, Lot, Happy	Personal Experiences or Expectations
People, Day, Every, One, Give, Four, Could, Always, Live, Help	Routine Life
LDA Model- Sarcastic Subset (Coherence Score=0.560)	
Kill, Love, Yeah, Like, Chill, Busy, Soda, Room, Spider, Spill	Leisure Activities
First, Would, Let, One, Film, Age, People, Forget, Name Close	Opinions of Others (In the Media)
Casual, Aware, Appropriate, Attire, Croc, Work, Show, Wow, Get, Nice	Appearance and Clothing
Don't, Think, There, Tell, Start, Enough, Suppose, Game, Ye, Get	Opinions and Thoughts
NMF Model- All Tweets (Coherence score=0.707)	
Kill, Love, Yeah, Spider, Soda, Room, Spill, Don't, Keyboard, There's	Undetermined
Like, Time, Really, Game, Day, Miss, Hurt, Thing, Love Effort	Personal Experiences
Super, City, Polite, Film, Confine, Villian, Awfully, Invasion, Particular, Hero	Fiction
Good, Guess, Collect, Change, End, Crime, Highly, Series, Episode, Usually	Evaluation and Opinions
NMF Model- Sarcastic Subset (Coherence score=0.689)	
Kill, Love, Yeah, Room, Soda, Spider, Don't Keyboard, Chilling	Undetermined
Super, City, Polite, Film, Villian, Awfully, Hero, Confine, Invasion, Particular	Fiction
Like Love, Stop, Smell, Sudden, Everybody, Train, Sandwich, Board, Philly	Preferences for Food
Collect, Good, Guess, Wait, Partner, Stanford, Unnecessarily, Ready, Order, Slot	Decision Making

Based on these assessments, the LDA method was determined to generate topics of greater value to the evaluation. This work additionally serves to demonstrate the limitations of such a method where

the topic is too broad; while some insights can be gained from the results, the topics are too broad to provide significant weight to associated findings, where they are not corroborated by more robust evidence.

11.10 Sarcasm Detection Model

The following section provides supplementary information regarding the preparation of data, and model selection process for the sarcasm detection model.

11.10.1 Data Preparation – Twitter Specific Text Features

Hashtags: To mitigate the impact of hashtag-based annotation strategies, hashtags relating to the words sarcasm and irony were eliminated from text strings. Remaining hashtags may contain useful information for the model thus a strategy to retain the words contained within the hashtags was implemented. The # symbol was separated from the associated text using a space. Compound word hashtags were separated using a camel-case split method where possible and a secondary strategy which extracted words from the string through comparison to a corpus of words. Observation of the data indicates that hashtags are a frequent source of sentiment incongruence between string components thus it is important to retain such information for later analysis.

Before hashtag splitting:

#LivingMyBestLife

Result:

Living My Best Life

URLs: URLs do not convey useful information in the same manner as hashtags and thus they were removed from the data.

User mentions: User mentions do not generally contain semantic or sentiment information, however their usage frequency was shown to have a significant difference in earlier work. For this reason, each user mention was converted into @user to homogenise their use and enable their consideration in model training.

11.10.2 Data Preparation – Emoji Features

Emoji separation: Emojis are regularly added to text consecutively, which presents a challenge in this context, where models may recognise the string of emojis as a single word. As embeddings are present for individual emojis, rather than combinations, emojis were separated using a space.

Emoticon to emoji conversion: Emoticons are series of characters which convey emotion, in a similar way to emojis. A dictionary which maps emoticons to their equivalent emoji was used to convert any instances identified for emoticons within the dataset so that the sentiment they wish to convey could be considered by the model.

11.10.3 Data Preparation – Grammatical Features

Special Characters: Some special characters, or combinations of special characters were deemed to be relevant for the purposes of sarcasm detection during previous analysis. These characters were retained and separated from adjacent text based for consideration during model training. Characters determined to be irrelevant were removed from the text. Consideration to grammar implemented in this process; characters such as hyphens and apostrophes within words were retained to preserve good grammar and align words with their presentation in the embedding.

Word case: All words were converted to lower case to ensure that instances of the same word were identified to be the same as word processing is case-sensitive.

Stopwords: Stopwords were removed as they do not offer insight in terms of sentiment or semantics to the models therefore are likely to primarily contribute noise to the model for this problem set.

Lemmatisation: Lemmatisation was carried out to reduce the granularity of similar words within the corpus. For example, where *joy* and *joyful* are both present in the data vocabulary, lemmatisation enables pattern recognition between these iterations of the same base word thus improving the models' ability to identify patterns in the text.

Contractions: Based on a similar principal to that described during lemmatisation, contractions serve to increase granularity in the dataset vocabulary, resulting in a more complex classification task. A dictionary to map contracted words to their long form equivalent was implemented to reduce this effect.

Slang: As slang is often not contained in word-vector corpus' and is highly prevalent in the dataset due to the nature of both sarcasm and social media user-generated content more broadly, it is important to implement methods for the model to consider the information within these words. A dictionary which maps slang to a more formal representation of the same information was used to convert the slang in the text to a format which could be considered within the boundaries of the word embeddings available.

Repeating characters: Repeating characters are similarly prevalent in sarcastic content on Twitter where they are used to convey information outside of the literal meaning of the words such as tone.

Given these instances cannot be considered in their present form, these words were condensed into a more grammatically correct form.

Validity of Tokens: Tokens were defined as valid where they had at least one character, any token which did not meet this definition was removed from the data.

11.10.4 Model Selection for Sarcasm Detection

The purpose of this section is to evaluate the identified neural network architectures for sarcasm detection based on the characteristics known about the sarcastic data from work carried out in previous chapters. Work to date indicates that patterns characterising sarcasm are highly complex and incongruence across between word sentiment is important. The position of emojis in the string is a relevant consideration however this work has not evaluated if this also applies to words. As sarcasm can be represented in many ways, the model must be able to generalise well.

CNN: CNNs are more commonly used in image processing, however, have been reported to yield good results in literature for NLP tasks, particularly classification tasks including sarcasm detection. In contrast to architectures such as GRU and LSTM, the model learns patterns across space rather than time. This results in a model which identifies commonly co-occurring words regardless of their position in the string as there is no mechanism for capturing long term dependencies. Given the relevance of emoji position in text, this is a limitation of this model. CNNs are however capable of learning complex features and have good generalisation abilities due to their pooling layers which reduces the dimensionality of the output, which may ensure only the most relevant information is retained (Soni, Chouhan and Rathore, 2022).

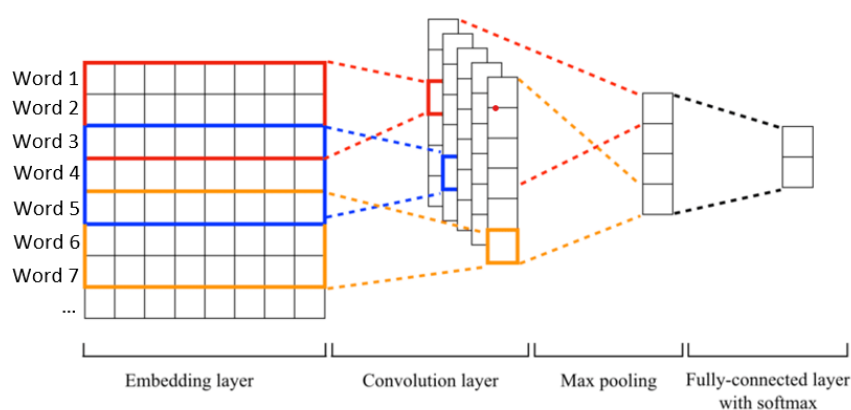

Figure 41 CNN model architecture for text processing.

LSTM: LSTM models process words sequentially, enabling them to consider word order for text prompts. Their ability to capture contextual information, facilitated by their memory cells discussed in section 11.5.2. The forget state within the architecture may facilitate good generalisation to unseen

data, which is important in the context of the task in question however the efficacy of this component to improve generalisation is situation dependent based on observations in literature thus it is important to test the model to determine the viability LSTM models for the task in question (Adamuthe, 2020).

GRU: GRU models have similar mechanisms to facilitate sequential data processing and capture of long-term dependencies as LSTM models, which are detailed in section 11.5.2. Observations in literature indicate that the differences in the architecture of its memory mechanism make it more suitable for shorter text sequences, indicating that they may be a viable option despite their lesser representation in sarcasm detection literature at present (Tang *et al.*, 2019).

11.11 Data Permissions

The inclusion of this section is pertinent to provide transparency with regards to sources of any data and resources used in this work. This serves to facilitate reproducibility, a critical component of the scientific method in addition to complying with legal requirements such as licensing agreements and ethical principles to attribute all data to its original authors.

11.11.1 Primary Data

The data generated during the primary research survey was collected following the obtaining of informed consent from each participant. In each response case, consent was provided and all expectations relating to the privacy and distribution of the obtained data established by the consent statement were adhered to. For these reasons, all necessary permissions were obtained for the use of this data and given its nature, the only licensing terms which are relevant are those which are detailed for the iSarcasm dataset in section 11.11.2.

11.11.2 Secondary Sources

This section details the relevant permissions for all secondary resources used throughout the course of this work. In each case, prior to the use of any data found online, verification was carried out to ensure that the intended use was within the scope of the permissions granted.

The following list details the resource titles, source references in addition to the relevant license type and text, attributions, and usage statements. Such information has been provided to provide maximal transparency in this work in addition to the adherence to legal requirements in many cases.

Title	iSarcasm
Source	GitHub: dmbavkar/iSarcasm: A Dataset of Intended Sarcasm (github.com) (Oprea and Magdy, 2022)
License Type	Creative Commons Attribution 4.0 International (CC BY 4.0)

License Text	<p>Permission is hereby granted, free of charge, to any person obtaining a copy of this software and associated documentation files (the "Software"), to deal in the Software without restriction, including without limitation the rights to use, copy, modify, merge, publish, distribute, sublicense, and/or sell copies of the Software, and to permit persons to whom the Software is furnished to do so, subject to the following conditions:</p> <p>The above copyright notice and this permission notice shall be included in all copies or substantial portions of the Software.</p> <p>THE SOFTWARE IS PROVIDED "AS IS", WITHOUT WARRANTY OF ANY KIND, EXPRESS OR IMPLIED, INCLUDING BUT NOT LIMITED TO THE WARRANTIES OF MERCHANTABILITY, FITNESS FOR A PARTICULAR PURPOSE AND NONINFRINGEMENT. IN NO EVENT SHALL THE AUTHORS OR COPYRIGHT HOLDERS BE LIABLE FOR ANY CLAIM, DAMAGES OR OTHER LIABILITY, WHETHER IN AN ACTION OF CONTRACT, TORT OR OTHERWISE, ARISING FROM, OUT OF OR IN CONNECTION WITH THE SOFTWARE OR THE USE OR OTHER DEALINGS IN THE SOFTWARE.</p>
Attribution	<p>This dataset was created by Oprea and Magdy in 2022 and is available on GitHub at: dmbavkar/iSarcasm: A Dataset of Intended Sarcasm (github.com). It is licensed under Creative Commons Attribution 4.0 International.</p>
Usage Statement	<p>This data was used to form the framework of the primary research survey. It was utilised as the baseline for which alternative datasets were measured during statistical evaluation, and finally its data was used during the training of the sarcasm detection model.</p>

Title	EmoTag 1200
Source	<p>GitHub: abushoeb/EmoTag: Emoji-Emotion dataset: An emoji-centric NLP resources based on Twitter Data (github.com) (Awal, Shoeb and de Melo, 2020)</p>
License Type	Creative Commons Attribution 4.0 International (CC BY 4.0)
License Text	<p>Permission is hereby granted, free of charge, to any person obtaining a copy of this software and associated documentation files (the "Software"), to deal in the Software without restriction, including without limitation the rights to use, copy, modify, merge, publish, distribute, sublicense, and/or sell copies of the Software, and to permit persons to whom the Software is furnished to do so, subject to the following conditions:</p> <p>The above copyright notice and this permission notice shall be included in all copies or substantial portions of the Software.</p> <p>THE SOFTWARE IS PROVIDED "AS IS", WITHOUT WARRANTY OF ANY KIND, EXPRESS OR IMPLIED, INCLUDING BUT NOT LIMITED TO THE WARRANTIES OF MERCHANTABILITY, FITNESS FOR A PARTICULAR PURPOSE AND NONINFRINGEMENT. IN NO EVENT SHALL THE AUTHORS OR COPYRIGHT HOLDERS BE LIABLE FOR ANY CLAIM, DAMAGES OR OTHER LIABILITY, WHETHER IN AN ACTION OF CONTRACT, TORT OR OTHERWISE, ARISING</p>

	FROM, OUT OF OR IN CONNECTION WITH THE SOFTWARE OR THE USE OR OTHER DEALINGS IN THE SOFTWARE.
Attribution	This dataset was created by Awal et. al. in 2020 and is available on GitHub at: abushoeb/EmoTag: Emoji-Emotion dataset: An emoji-centric NLP resources based on Twitter Data (github.com) . It is licensed under Creative Commons Attribution 4.0 International.
Usage Statement	This data was used for exploratory analysis and contributed to the work carried out for the prediction of basic theory data.

Title	Emoji Sentiment Ranking 1.0
Source	Source: Emoji Sentiment Ranking v1.0 (ijss.si) (K. Novak <i>et al.</i> , 2015)
License Type	Attribution-ShareAlike 4.0 International (CC BY-SA 4.0)
License Text	Permission is hereby granted, free of charge, to any person obtaining a copy of this software and associated documentation files (the "Software"), to deal in the Software without restriction, including without limitation the rights to use, copy, modify, merge, publish, distribute, sublicense, and/or sell copies of the Software, and to permit persons to whom the Software is furnished to do so, subject to the following conditions: The above copyright notice and this permission notice shall be included in all copies or substantial portions of the Software. THE SOFTWARE IS PROVIDED "AS IS", WITHOUT WARRANTY OF ANY KIND, EXPRESS OR IMPLIED, INCLUDING BUT NOT LIMITED TO THE WARRANTIES OF MERCHANTABILITY, FITNESS FOR A PARTICULAR PURPOSE AND NONINFRINGEMENT. IN NO EVENT SHALL THE AUTHORS OR COPYRIGHT HOLDERS BE LIABLE FOR ANY CLAIM, DAMAGES OR OTHER LIABILITY, WHETHER IN AN ACTION OF CONTRACT, TORT OR OTHERWISE, ARISING FROM, OUT OF OR IN CONNECTION WITH THE SOFTWARE OR THE USE OR OTHER DEALINGS IN THE SOFTWARE.
Attribution	This dataset was created by Novak et. al. in 2015 and is available at: Emoji Sentiment Ranking v1.0 (ijss.si) . It is licensed under Attribution-ShareAlike 4.0 International (CC BY-SA 4.0).
Usage Statement	This data was used for exploratory analysis and contributed to the work carried out for the prediction of dimensional theory data.

Title	SentiWordNet
Source	GitHub: aesuli/SentiWordNet: The SentiWordNet sentiment lexicon (github.com) (Esuli and Bond, 2022)
License Type	Attribution-ShareAlike 4.0 International (CC BY-SA 4.0)
License Text	Permission is hereby granted, free of charge, to any person obtaining a copy of this software and associated documentation files (the "Software"), to deal in the Software without restriction, including without limitation the rights to

	<p>use, copy, modify, merge, publish, distribute, sublicense, and/or sell copies of the Software, and to permit persons to whom the Software is furnished to do so, subject to the following conditions:</p> <p>The above copyright notice and this permission notice shall be included in all copies or substantial portions of the Software.</p> <p>THE SOFTWARE IS PROVIDED "AS IS", WITHOUT WARRANTY OF ANY KIND, EXPRESS OR IMPLIED, INCLUDING BUT NOT LIMITED TO THE WARRANTIES OF MERCHANTABILITY, FITNESS FOR A PARTICULAR PURPOSE AND NONINFRINGEMENT. IN NO EVENT SHALL THE AUTHORS OR COPYRIGHT HOLDERS BE LIABLE FOR ANY CLAIM, DAMAGES OR OTHER LIABILITY, WHETHER IN AN ACTION OF CONTRACT, TORT OR OTHERWISE, ARISING FROM, OUT OF OR IN CONNECTION WITH THE SOFTWARE OR THE USE OR OTHER DEALINGS IN THE SOFTWARE.</p>
Attribution	<p>SentiWordNet was created by Esuli & Bond in 2022 and is available at: aesuli/SentiWordNet: The SentiWordNet sentiment lexicon (github.com)</p> <p>It is distributed under the Attribution-ShareAlike 4.0 Unported (CC BY-SA 4.0) license.</p>
Usage Statement	<p>This resource was used to generate sentiment intensity values for the sentiment-aware attention mechanism.</p>

Title	Emo2Vec
Source	<p>GitHub: glnmario/emo2vec: Semi-supervised emotion lexicon expansion with label propagation and specialized word embeddings (github.com)</p> <p>(Giulianelli, 2017)</p>
License Type	BSD-3-Clause
License Text	<p>Redistribution and use in source and binary forms, with or without modification, are permitted provided that the following conditions are met:</p> <ol style="list-style-type: none"> 1. Redistributions of source code must retain the above copyright notice, this list of conditions and the following disclaimer. 2. Redistributions in binary form must reproduce the above copyright notice, this list of conditions and the following disclaimer in the documentation and/or other materials provided with the distribution. 3. Neither the name of the copyright holder nor the names of its contributors may be used to endorse or promote products derived from this software without specific prior written permission. <p>THIS SOFTWARE IS PROVIDED BY THE COPYRIGHT HOLDERS AND CONTRIBUTORS "AS IS" AND ANY EXPRESS OR IMPLIED WARRANTIES, INCLUDING, BUT NOT LIMITED TO, THE IMPLIED WARRANTIES OF MERCHANTABILITY AND FITNESS FOR A PARTICULAR PURPOSE ARE DISCLAIMED. IN NO EVENT SHALL THE COPYRIGHT HOLDER OR CONTRIBUTORS BE LIABLE FOR ANY DIRECT, INDIRECT, INCIDENTAL, SPECIAL, EXEMPLARY, OR CONSEQUENTIAL DAMAGES (INCLUDING, BUT NOT LIMITED TO, PROCUREMENT OF SUBSTITUTE GOODS OR SERVICES; LOSS OF USE, DATA, OR PROFITS; OR BUSINESS INTERRUPTION) HOWEVER CAUSED AND ON ANY THEORY OF LIABILITY, WHETHER IN CONTRACT, STRICT LIABILITY, OR TORT (INCLUDING NEGLIGENCE OR OTHERWISE)</p>

	ARISING IN ANY WAY OUT OF THE USE OF THIS SOFTWARE, EVEN IF ADVISED OF THE POSSIBILITY OF SUCH DAMAGE.
Attribution	Emo2Vec was created by Giulianelli M. in 2017 and is available on GitHub at: glnmario/emo2vec: Semi-supervised emotion lexicon expansion with label propagation and specialized word embeddings (github.com) It is licensed under BSD-3-Clause.
Usage Statement	This resource contains the word vectors for the emojis used for sentiment extraction in addition to the sarcasm detection model embedding matrix.

Title	NRC Emotion Intensity Lexicon
Source	Source: NRC Affect Intensity Lexicon (saifmohammad.com) (Mohammad, 2022)
License Type	Attribution NonCommercial 4.0 International License (CC BY-NC 4.0)
License Text	<p>Permission is hereby granted, free of charge, to any person obtaining a copy of this software and associated documentation files (the "Software"), to deal in the Software without restriction, including without limitation the rights to use, copy, modify, merge, publish, distribute, sublicense, and/or sell copies of the Software, and to permit persons to whom the Software is furnished to do so, subject to the following conditions:</p> <p>The above copyright notice and this permission notice shall be included in all copies or substantial portions of the Software.</p> <p>THE SOFTWARE IS PROVIDED "AS IS", WITHOUT WARRANTY OF ANY KIND, EXPRESS OR IMPLIED, INCLUDING BUT NOT LIMITED TO THE WARRANTIES OF MERCHANTABILITY, FITNESS FOR A PARTICULAR PURPOSE AND NONINFRINGEMENT. IN NO EVENT SHALL THE AUTHORS OR COPYRIGHT HOLDERS BE LIABLE FOR ANY CLAIM, DAMAGES OR OTHER LIABILITY, WHETHER IN AN ACTION OF CONTRACT, TORT OR OTHERWISE, ARISING FROM, OUT OF OR IN CONNECTION WITH THE SOFTWARE OR THE USE OR OTHER DEALINGS IN THE SOFTWARE.</p>
Attribution	NRC Emotion Intensity Lexicon was created by Mohammad S. in 2022 and is available at: NRC Affect Intensity Lexicon (saifmohammad.com) It is distributed under the Attribution NonCommercial 4.0 International License (CC BY-NC 4.0).
Usage Statement	This resource contains data which was used for the feature extraction for emoji sentiment data.

Title	Word2Vec Google News Vectors
Source	Source: Google Code Archive - Long-term storage for Google Code Project Hosting. (Mikolov <i>et al.</i> , 2013)
License Type	Apache License 2.0
License Text	Licensed under the Apache License, Version 2.0 (the "License"); you may not use this file except in compliance with the License. You may obtain a copy of the License at:

	<p>http://www.apache.org/licenses/LICENSE-2.0</p> <p>Unless required by applicable law or agreed to in writing, software distributed under the License is distributed on an "AS IS" BASIS, WITHOUT WARRANTIES OR CONDITIONS OF ANY KIND, either express or implied. See the License for the specific language governing permissions and limitations under the License.</p>
Attribution	<p>This resource was created by Google in 2013 and is available at: Google Code Archive - Long-term storage for Google Code Project Hosting.</p> <p>It is distributed under the Apache License 2.0.</p>
Usage Statement	<p>This resource contains the word vectors which were used for the sarcasm detection model alongside the emoji vectors.</p>

11.12 Survey Responses

This section contains each survey response, where participants are assigned a sequential number in the order which their response was processed.

Participant Number	1
Question	Response
Qualification questions	
Consent to participate.	Yes
Are you over 18?	Yes
Do you use emojis?	Yes
Demographic Questions	
What is your gender?	Female
What age are you?	18-24
What is sarcasm?	When you say something that is obviously not the right answer
Emoji Usage Questions	
The only thing I got from college was a caffeine addiction What is true of this tweet?	It is sarcastic
What emojis (if any) would you add to this tweet?	The only thing I got from college was a caffeine addiction 😏
@WalesOnline Riveting news. What is true of this tweet?	I don't know
What emojis (if any) would you add to this tweet?	@WalesOnline Riveting news.
"My (extended) fam was discussing going on a trip instead of getting presents for Christmas, like okay Im bout it... Yeah they were talking about doing to the dells. Ill take my god damn presents thank you very much" What is true of this tweet?	It is sarcastic

What emojis (if any) would you add to this tweet?	"My (extended) fam was discussing going on a trip instead of getting presents for Christmas, like okay Im bout it... Yeah they were talking about doing to the dells. Ill take my god damn presents thank you very much" 🤔
i love shoegaze sm What is true of this tweet?	It is sarcastic
What emojis (if any) would you add to this tweet?	i love shoegaze sm 😊
men are so grimey What is true of this tweet?	It is sarcastic
What emojis (if any) would you add to this tweet?	men are so grimey 😞
okay but like the say so song aint that bad. Im unironically jam to it lmao What is true of this tweet?	It is sarcastic
What emojis (if any) would you add to this tweet?	okay but like the say so song aint that bad. Im unironically jam to it lmao 😂
Tinnitus is my favourite thing ever I love it. So loud so atmospheric https://t.co/mNJw5GvPzy What is true of this tweet?	It is sarcastic
What emojis (if any) would you add to this tweet?	Tinnitus is my favourite thing ever I love it. So loud so atmospheric https://t.co/mNJw5GvPzy 🙈
i hate when that guy on tiktok is all i uNdeRsTAnd iTs eASy tO keEp wAtChInG vIdEos.👉 LIKE BRO MIND YA BUSINESS What is true of this tweet?	It is sarcastic
What emojis (if any) would you add to this tweet?	i hate when that guy on tiktok is all i uNdeRsTAnd iTs eASy tO keEp wAtChInG vIdEos.👉 LIKE BRO MIND YA BUSINESS 😊
am honestly so disturbed by the star signs changes?? like Im a Scorpio not a libra?? am so so stressed What is true of this tweet?	I don't know
What emojis (if any) would you add to this tweet?	am honestly so disturbed by the star signs changes?? like Im a Scorpio not a libra?? am so so stressed
love living in a capitalist society where i look forward to getting a surgery where im legit GETTING AN INTERNAL BODY PART REMOVED bc it means ill get a few days off from work xoxo What is true of this tweet?	It is sarcastic
What emojis (if any) would you add to this tweet?	love living in a capitalist society where i look forward to getting a surgery where im legit GETTING AN INTERNAL BODY PART REMOVED bc it means ill get a few days off from work xoxo 😊

Do you have any comments you would like to make?	n/a
--	-----

Participant Number	2
Question	Response
Qualification questions	
Consent to participate.	Yes
Are you over 18?	Yes
Do you use emojis?	Yes
Demographic Questions	
What is your gender?	Male
What age are you?	18-24
What is sarcasm?	It's making a snide remark to someone to convey to them that they are wrong, stupid, don't understand something etc. in either a positive or negative way.
Emoji Usage Questions	
The only thing I got from college was a caffeine addiction What is true of this tweet?	It is sarcastic
What emojis (if any) would you add to this tweet?	The only thing I got from college is a caffeine addiction 😭
Holly Arnold ??? Who #ImACeleb #MBE nope not sure oh hang on you mean MBE yes thats her !!! What is true of this tweet?	I don't know
What emojis (if any) would you add to this tweet?	Holly Arnold ??? Who #ImACeleb #MBE nope not sure oh hang on you mean MBE yes thats her !!!
ANY PENSIONER AND 4 YEAR OLD WHO DARE TAKE ME ON AT DINOSAUR THEMED CRAZY GOLF WILL BE CRUSHED, CRUSHED I TELL YOU. https://t.co/yZlafy0lSd What is true of this tweet?	It is sarcastic
What emojis (if any) would you add to this tweet?	ANY PENSIONER AND 4 YEAR OLD WHO DARE TAKE ME ON AT DINOSAUR THEMED CRAZY GOLF WILL BE CRUSHED, CRUSHED I TELL YOU. 😡 https://t.co/yZlafy0lSd
in desperate need of (and I can NOT stress this enough) spring break What is true of this tweet?	It is not sarcastic
What emojis (if any) would you add to this tweet?	in desperate need of (and I can NOT stress this enough) spring break
I've said it before and I'll say it again but YOUR MENTAL HEALTH IS SO MUCH MORE IMPORTANT	It is not sarcastic

THAN A GOOD GRADE What is true of this tweet?	
What emojis (if any) would you add to this tweet?	I've said it before and I'll say it again but YOUR MENTAL HEALTH IS SO MUCH MORE IMPORTANT THAN A GOOD GRADE
See Brexit is going well What is true of this tweet?	It is sarcastic
What emojis (if any) would you add to this tweet?	See Brexit is going well
Just like to congratulate everyone on the Kop today for the fastest ever Poor Scouser Tommy. Slow the fuck down What is true of this tweet?	It is sarcastic
What emojis (if any) would you add to this tweet?	Just like to congratulate everyone on the Kop today for the fastest ever Poor Scouser Tommy. Slow the fuck down
I couldnt have imagined how much fun I would have with people Ive met through streaming. Im so thankful to live in this timeline even if it is relatively garbage. What is true of this tweet?	It is not sarcastic
What emojis (if any) would you add to this tweet?	I couldnt have imagined how much fun I would have with people Ive met through streaming. Im so thankful to live in this timeline even if it is relatively garbage.
woke up to my dog sneezing on my face. Hows your day going so far? What is true of this tweet?	It is sarcastic
What emojis (if any) would you add to this tweet?	woke up to my dog sneezing on my face. Hows your day going so far?
do i just blast maneskin to get hyped for my osce or?? What is true of this tweet?	It is not sarcastic
What emojis (if any) would you add to this tweet?	do i just blast maneskin to get hyped for my osce or??
Do you have any comments you would like to make?	

Participant Number	3
Question	Response
Qualification questions	

Consent to participate.	Yes
Are you over 18?	Yes
Do you use emojis?	Yes
Demographic Questions	
What is your gender?	I don't want to say
What age are you?	25-34
What is sarcasm?	Sarcasm is a form of verbal irony that involves saying something to convey the opposite of its literal meaning, often with the intention of humor, criticism, or mockery. It is a type of communication where the speaker says one thing but means the opposite, and it is usually recognizable through tone of voice, context, or other cues.
Emoji Usage Questions	
The only thing I got from college is a caffeine addiction What is true of this tweet?	It is sarcastic
What emojis (if any) would you add to this tweet?	The only thing I got from college is a caffeine addiction 😊
Holly Arnold ??? Who #ImACeleb #MBE nope not sure oh hang on you mean MBE yes thats her !!! What is true of this tweet?	I don't know
What emojis (if any) would you add to this tweet?	Holly Arnold ??? Who #ImACeleb #MBE nope not sure oh hang on you mean MBE yes thats her !!! 😞
ANY PENSIONER AND 4 YEAR OLD WHO DARE TAKE ME ON AT DINOSAUR THEMED CRAZY GOLF WILL BE CRUSHED, CRUSHED I TELL YOU. https://t.co/yZlafy0lsd What is true of this tweet?	It is not sarcastic
What emojis (if any) would you add to this tweet?	ANY PENSIONER AND 4 YEAR OLD WHO DARE TAKE ME ON AT DINOSAUR THEMED CRAZY GOLF WILL BE CRUSHED, CRUSHED I TELL YOU. https://t.co/yZlafy0lsd 😄😂
in desperate need of (and I can NOT stress this enough) spring break What is true of this tweet?	It is not sarcastic
What emojis (if any) would you add to this tweet?	in desperate need of (and I can NOT stress this enough) spring break 😭
I've said it before and I'll say it again but YOUR MENTAL HEALTH IS SO MUCH MORE IMPORTANT THAN A GOOD GRADE What is true of this tweet?	It is not sarcastic

What emojis (if any) would you add to this tweet?	I've said it before and I'll say it again but YOUR MENTAL HEALTH IS SO MUCH MORE IMPORTANT THAN A GOOD GRADE 😞
See Brexit is going well What is true of this tweet?	It is sarcastic
What emojis (if any) would you add to this tweet?	See Brexit is going well 😊😞
Just like to congratulate everyone on the Kop today for the fastest ever Poor Scouser Tommy. Slow the fuck down What is true of this tweet?	It is sarcastic
What emojis (if any) would you add to this tweet?	Just like to congratulate everyone on the Kop today for the fastest ever Poor Scouser Tommy. Slow the fuck down 😊
I couldn't have imagined how much fun I would have with people I've met through streaming. I'm so thankful to live in this timeline even if it is relatively garbage. What is true of this tweet?	It is not sarcastic
What emojis (if any) would you add to this tweet?	I couldn't have imagined how much fun I would have with people I've met through streaming. I'm so thankful to live in this timeline even if it is relatively garbage. 😊😊
woke up to my dog sneezing on my face. How's your day going so far? What is true of this tweet?	It is not sarcastic
What emojis (if any) would you add to this tweet?	woke up to my dog sneezing on my face. How's your day going so far? 😞
do i just blast maneskin to get hyped for my osce or?? What is true of this tweet?	I don't know
What emojis (if any) would you add to this tweet?	do i just blast maneskin to get hyped for my osce or?? 😞
Do you have any comments you would like to make?	

Participant Number	4
Question	Response
Qualification questions	
Consent to participate.	Yes
Are you over 18?	Yes

Do you use emojis?	Yes
Demographic Questions	
What is your gender?	Female
What age are you?	18-24
What is sarcasm?	some kind of humor where things that are kind of bad are seen in a humoristic way
Emoji Usage Questions	
The only thing I got from college is a caffeine addiction What is true of this tweet?	It is sarcastic
What emojis (if any) would you add to this tweet?	The only thing I got from college is a caffeine addiction 🙄
@heathoween @tylerrjoseph Yes, because we need literally every single fucking celebrity to speak up on a topic that's been forced down everyone's throats for the past four months. I use the internet to get away from these fucking real life problems; not everyone needs to weigh in. What is true of this tweet?	It is not sarcastic
What emojis (if any) would you add to this tweet?	@heathoween @tylerrjoseph Yes, because we need literally every single fucking celebrity to speak up on a topic that's been forced down everyone's throats for the past four months. I use the internet to get away from these fucking real life problems; not everyone needs to weigh in. 😊😞
I never thought I'd say this, but I have become one of those people who like bounty bars. What is true of this tweet?	It is not sarcastic
What emojis (if any) would you add to this tweet?	I never thought I'd say this, but I have become one of those people who like bounty bars. 😂😂
Does the salad offset the beer(s)? What is true of this tweet?	It is not sarcastic
What emojis (if any) would you add to this tweet?	Does the salad offset the beer(s)? 🤔
Why do I have a doctorate and miss the restaurant industry SO MUCH What is true of this tweet?	It is not sarcastic
What emojis (if any) would you add to this tweet?	Why do I have a doctorate and miss the restaurant industry SO MUCH 🤔
Whoever's toddler ass sprayed the entire toilet backstage, I hope you stub your toe and bite your tongue really hard. also you were clearly	It is sarcastic

dehydrated, go drink some damn water like an adult What is true of this tweet?	
What emojis (if any) would you add to this tweet?	Whoever's toddler ass sprayed the entire toilet backstage, I hope you stub your toe and bite your tongue really hard. also you were clearly dehydrated, go drink some damn water like an adult 😏
gaslight gatekeep girl boss What is true of this tweet?	It is sarcastic
What emojis (if any) would you add to this tweet?	gaslight gatekeep girl boss 🖊️
The more you toot the more you poop👉 -my 6 yo nephew What is true of this tweet?	It is not sarcastic
What emojis (if any) would you add to this tweet?	The more you toot the more you poop👉 -my 6 yo nephew 🐛
Perk of doing a newborn hearing screening on an SLPs baby: not having to discuss speech and language milestones What is true of this tweet?	I don't know
What emojis (if any) would you add to this tweet?	Perk of doing a newborn hearing screening on an SLPs baby: not having to discuss speech and language milestones
I was only in Taylor Swifts top 0.10% of listeners on Spotify but last year but yeah totally sound that Swiftogeddan in Glasgow is sold out What is true of this tweet?	It is not sarcastic
What emojis (if any) would you add to this tweet?	I was only in Taylor Swifts top 0.10% of listeners on Spotify but last year but yeah totally sound that Swiftogeddan in Glasgow is sold out 😊
Do you have any comments you would like to make?	

Participant Number	5
Question	Response
Qualification questions	
Consent to participate.	Yes
Are you over 18?	Yes
Do you use emojis?	Yes

Demographic Questions	
What is your gender?	Female
What age are you?	18-24
What is sarcasm?	Ironic humour
Emoji Usage Questions	
The only thing I got from college is a caffeine addiction What is true of this tweet?	It is sarcastic
What emojis (if any) would you add to this tweet?	The only thing I got from college is a caffeine addiction 🤔
So we actually have to do hot girl summer without 1989 Taylors version., Im sick What is true of this tweet?	I don't know
What emojis (if any) would you add to this tweet?	So we actually have to do hot girl summer without 1989 Taylors version., Im sick
considering crowd surfing the next time the hallways are too packed What is true of this tweet?	It is sarcastic
What emojis (if any) would you add to this tweet?	considering crowd surfing the next time the hallways are too packed 😞
"Amazing! Simply amazing. Well done Sky Brown. You are an inspiration to all of us. https://t.co/VppUp4n7Y0 " What is true of this tweet?	It is not sarcastic
What emojis (if any) would you add to this tweet?	"Amazing! Simply amazing. Well done Sky Brown. You are an inspiration to all of us. https://t.co/VppUp4n7Y0 " 🙌
I'm settled for a night in front of the TV watching #SoccerAid What is true of this tweet?	I don't know
What emojis (if any) would you add to this tweet?	I'm settled for a night in front of the TV watching #SoccerAid
Avoid mass gatherings.. does this mean that I can stay home tomorrow as I work at a school? No I thought not. #schoolclosure What is true of this tweet?	It is not sarcastic
What emojis (if any) would you add to this tweet?	Avoid mass gatherings.. does this mean that I can stay home tomorrow as I work at a school? No I thought not. #schoolclosure
You know the wolves match is boring when you're talking with your mate about the best way to wire	It is sarcastic

up his new shed! What is true of this tweet?	
What emojis (if any) would you add to this tweet?	You know the wolves match is boring when you're talking with your mate about the best way to wire up his new shed!
"attack on Titan Im not ok Saw a few leaks on purpose bc I like to torture myself and Ill wait to read the whole chapter tomorrow but oh my god oh my god Im hurting" What is true of this tweet?	It is sarcastic
What emojis (if any) would you add to this tweet?	"attack on Titan Im not ok Saw a few leaks on purpose bc I like to torture myself and Ill wait to read the whole chapter tomorrow but oh my god oh my god Im hurting"
drive to work with no music kinda day What is true of this tweet?	It is not sarcastic
What emojis (if any) would you add to this tweet?	drive to work with no music kinda day
What a wonderful time to have your AC go out https://t.co/jqjqG1dGOa What is true of this tweet?	It is sarcastic
What emojis (if any) would you add to this tweet?	What a wonderful time to have your AC go out https://t.co/jqjqG1dGOa
Do you have any comments you would like to make?	why would i add emojis to some of these...boomer vibes tbh

Participant Number	6
Question	Response
Qualification questions	
Consent to participate.	Yes
Are you over 18?	Yes
Do you use emojis?	Yes
Demographic Questions	
What is your gender?	Male
What age are you?	18-24
What is sarcasm?	humoristic comment meaning its literal opposite
Emoji Usage Questions	

The only thing I got from college is a caffeine addiction What is true of this tweet?	It is sarcastic
What emojis (if any) would you add to this tweet?	The only thing I got from college is a caffeine addiction 🤪🌀😭😞☐
What a Race ! #sarcastic #WTF1 https://t.co/zRtL5alnoT What is true of this tweet?	It is not sarcastic
What emojis (if any) would you add to this tweet?	What a Race ! #sarcastic #WTF1 https://t.co/zRtL5alnoT
help! i'm being haunted by dead people! (my dissertations) What is true of this tweet?	It is sarcastic
What emojis (if any) would you add to this tweet?	help! i'm being haunted by dead people! (my dissertations) 😞
@JohnJBrea @lad_lew @Ladyblueclr @realDonaldTrump It's probably something closer to Xenophobia. Which is someone hating someone else just because they're foreign. I mean, you are an English teacher, aren't you? Figured you might know that. What is true of this tweet?	It is sarcastic
What emojis (if any) would you add to this tweet?	@JohnJBrea @lad_lew @Ladyblueclr @realDonaldTrump It's probably something closer to Xenophobia. Which is someone hating someone else just because they're foreign. I mean, you are an English teacher, aren't you? Figured you might know that.
@miiniigun I feel that 100%, my anxiety stops me from talking to so many people. I've let so many friendships die because I can't push myself to talk to them. What is true of this tweet?	It is not sarcastic
What emojis (if any) would you add to this tweet?	@miiniigun I feel that 100%, my anxiety stops me from talking to so many people. I've let so many friendships die because I can't push myself to talk to them.
my neighbors taunting me outside my office window by chilling in their hot tub every remotely warm day whilst I sit here on back-to-back zooms all day every day. the audacity is astonishing. What is true of this tweet?	It is sarcastic

What emojis (if any) would you add to this tweet?	my neighbors taunting me outside my office window by chilling in their hot tub every remotely warm day whilst I sit here on back-to-back zooms all day every day. the audacity is astonishing. 😞😞
Billy Gunn sorta relevant for the first time in years... What is true of this tweet?	I don't know
What emojis (if any) would you add to this tweet?	Billy Gunn sorta relevant for the first time in years...
Well done @WestHam and @premierleague, great leadership! https://t.co/4IPXaK0Jpu What is true of this tweet?	It is not sarcastic
What emojis (if any) would you add to this tweet?	Well done @WestHam and @premierleague, great leadership! https://t.co/4IPXaK0Jpu
Congratulations Jayden. A worthy winner of the award and a bright future ahead of you. https://t.co/iBMOFAIjcp What is true of this tweet?	It is not sarcastic
What emojis (if any) would you add to this tweet?	Congratulations Jayden. A worthy winner of the award and a bright future ahead of you. https://t.co/iBMOFAIjcp
wish i could understand string theory without knowing math..... alas i guess i am too hot for conceptual physics What is true of this tweet?	It is sarcastic
What emojis (if any) would you add to this tweet?	wish i could understand string theory without knowing math..... alas i guess i am too hot for conceptual physics 🙄
Do you have any comments you would like to make?	

Participant Number	7
Question	Response
Qualification questions	
Consent to participate.	Yes
Are you over 18?	Yes
Do you use emojis?	Yes
Demographic Questions	
What is your gender?	Female
What age are you?	35-44

What is sarcasm?	saying mean things in funny way
Emoji Usage Questions	
The villains in super hero films are awfully polite. They always confine their invasions to being above one particular city a single man directed by tom ford simultaneously resurrected me from death only to brutally murder me once more.	It is sarcastic
What emojis (if any) would you add to this tweet?	The villains in super hero films are awfully polite. They always confine their invasions to being above one particular city
I love when you go to shop for plus size clothing and it's always just shoved under women's and it doesn't have any subcategories so u just have to wade thru everything like a pig being thrown slop a single man directed by tom ford simultaneously resurrected me from death only to brutally murder me once more.	It is sarcastic
What emojis (if any) would you add to this tweet?	I love when you go to shop for plus size clothing and it's always just shoved under women's and it doesn't have any subcategories so u just have to wade thru everything like a pig being thrown slop 🐷
Thank god I just accidentally snapped a rando guy from high school yas queen with acne cream all over my face a single man directed by tom ford simultaneously resurrected me from death only to brutally murder me once more.	I don't know
What emojis (if any) would you add to this tweet?	Thank god I just accidentally snapped a rando guy from high school yas queen with acne cream all over my face
I hurt my foot like 3 days ago, I have no idea how, but it hurts to put pressure on it. Love that for me a single man directed by tom ford simultaneously resurrected me from death only to brutally murder me once more.	It is sarcastic
What emojis (if any) would you add to this tweet?	I hurt my foot like 3 days ago, I have no idea how, but it hurts to put pressure on it. Love that for me 😞
Grealish is just good. You hate to admit it, but damn. a single man directed by tom ford simultaneously resurrected me from death only to brutally murder me once more.	It is not sarcastic
What emojis (if any) would you add to this tweet?	Grealish is just good. You hate to admit it, but damn.

<p>A Christmas story. About three years ago my Mum told me that shed bought me a present: she wasnt sure if Id like it, whether it was my kind of thing or not, but shed loved it so shed bought it and put it away. And then she lost it. https://t.co/r9lxwYE7p7 a single man directed by tom ford simultaneously resurrected me from death only to brutally murder me once more.</p>	<p>It is not sarcastic</p>
<p>What emojis (if any) would you add to this tweet?</p>	<p>A Christmas story. About three years ago my Mum told me that shed bought me a present: she wasnt sure if Id like it, whether it was my kind of thing or not, but shed loved it so shed bought it and put it away. And then she lost it. https://t.co/r9lxwYE7p7 😞</p>
<p>"me: trying to sleep slightly earlier than usual bc I feel like shit my friend, texting the group chat 13 separate times at nearly 4am: hello I dont think so! how abt I tell u abt how bad things are going instead :)" a single man directed by tom ford simultaneously resurrected me from death only to brutally murder me once more.</p>	<p>I don't know</p>
<p>What emojis (if any) would you add to this tweet?</p>	<p>"me: trying to sleep slightly earlier than usual bc I feel like shit my friend, texting the group chat 13 separate times at nearly 4am: hello I dont think so! how abt I tell u abt how bad things are going instead :)"</p>
<p>5:30 banshee-like kitten zoomies are definitely my all-time favorite alarm clock, and the sound of jewelry boxes flipping over and burnouts on the wood floor make for the calmest, most enjoyable start to any workday. a single man directed by tom ford simultaneously resurrected me from death only to brutally murder me once more.</p>	<p>It is sarcastic</p>
<p>What emojis (if any) would you add to this tweet?</p>	<p>5:30 banshee-like kitten zoomies are definitely my all-time favorite alarm clock, and the sound of jewelry boxes flipping over and burnouts on the wood floor make for the calmest, most enjoyable start to any workday. 😏</p>
<p>"I wish Facebook would introduce a rude option on its like panel. I feel wow doesnt cover it. Maybe it could be a middle finger." a single man directed by tom ford simultaneously resurrected me from death only to brutally murder me once more.</p>	<p>It is not sarcastic</p>
<p>What emojis (if any) would you add to this tweet?</p>	<p>"I wish Facebook would introduce a rude option on its like panel. I feel wow doesnt cover it. Maybe it could be a middle finger."</p>

"I wanted to be so much harsher about Zoom meetings. https://t.co/fr3GcEjvOV " a single man directed by tom ford simultaneously resurrected me from death only to brutally murder me once more.	It is not sarcastic
What emojis (if any) would you add to this tweet?	"I wanted to be so much harsher about Zoom meetings. https://t.co/fr3GcEjvOV "
Do you have any comments you would like to make?	

Participant Number	8
Question	Response
Qualification questions	
Consent to participate.	Yes
Are you over 18?	Yes
Do you use emojis?	Yes
Demographic Questions	
What is your gender?	Female
What age are you?	25-34
What is sarcasm?	When you respond to some in a way that you think the answer is obvious
Emoji Usage Questions	
The villains in super hero films are awfully polite. They always confine their invasions to being above one particular city a single man directed by tom ford simultaneously resurrected me from death only to brutally murder me once more.	It is sarcastic
What emojis (if any) would you add to this tweet?	The villains in super hero films are awfully polite. They always confine their invasions to being above one particular city 😏
Hey Siri, how do I stop simping? a single man directed by tom ford simultaneously resurrected me from death only to brutally murder me once more.	It is sarcastic
What emojis (if any) would you add to this tweet?	Hey Siri, how do I stop simping? 🙄
please i just want a gp that can prescribe me my bridging hormones a single man directed by tom ford simultaneously resurrected me from death only to brutally murder me once more.	It is not sarcastic

What emojis (if any) would you add to this tweet?	please i just want a gp that can prescribe me my bridging hormones
I am so fucking tired of living in the UK. a single man directed by tom ford simultaneously resurrected me from death only to brutally murder me once more.	It is not sarcastic
What emojis (if any) would you add to this tweet?	I am so fucking tired of living in the UK.
Hey does anyone know of any organizations that have massive stockpiles of money that could be super useful to the world during a public crisis???? a single man directed by tom ford simultaneously resurrected me from death only to brutally murder me once more.	It is sarcastic
What emojis (if any) would you add to this tweet?	Hey does anyone know of any organizations that have massive stockpiles of money that could be super useful to the world during a public crisis???? 🤔
Wow Bdubs can bench press 150 kilometers a single man directed by tom ford simultaneously resurrected me from death only to brutally murder me once more.	It is sarcastic
What emojis (if any) would you add to this tweet?	Wow Bdubs can bench press 150 kilometers
Someone on reddit the other day said that I 'ooze enby energy' and I've been riding that high for the whole weekend. a single man directed by tom ford simultaneously resurrected me from death only to brutally murder me once more.	It is not sarcastic
What emojis (if any) would you add to this tweet?	Someone on reddit the other day said that I 'ooze enby energy' and I've been riding that high for the whole weekend. 😊
yall ever chip your tooth from accidentally biting your tongue ring a single man directed by tom ford simultaneously resurrected me from death only to brutally murder me once more.	It is not sarcastic
What emojis (if any) would you add to this tweet?	yall ever chip your tooth from accidentally biting your tongue ring 🤢
Nothing screams Im a glamorous cosmopolitan woman like following your dog down the street in the midst of winter, saying go potty! Go POTTY! over and over again. a single man directed by tom ford simultaneously	It is sarcastic

resurrected me from death only to brutally murder me once more.	
What emojis (if any) would you add to this tweet?	Nothing screams Im a glamorous cosmopolitan woman like following your dog down the street in the midst of winter, saying go potty! Go POTTY! over and over again.
Heard a rumor that Baja Blast is coming to stores and regardless if anything else I hope for in life falls through, at least I'll have this. a single man directed by tom ford simultaneously resurrected me from death only to brutally murder me once more.	It is sarcastic
What emojis (if any) would you add to this tweet?	Heard a rumor that Baja Blast is coming to stores and regardless if anything else I hope for in life falls through, at least I'll have this.
Do you have any comments you would like to make?	No

Participant Number	9
Question	Response
Qualification questions	
Consent to participate.	Yes
Are you over 18?	Yes
Do you use emojis?	Yes
Demographic Questions	
What is your gender?	Female
What age are you?	25-34
What is sarcasm?	Saying something but having the opposite meaning
Emoji Usage Questions	
The villains in super hero films are awfully polite. They always confine their invasions to being above one particular city a single man directed by tom ford simultaneously resurrected me from death only to brutally murder me once more.	It is sarcastic
What emojis (if any) would you add to this tweet?	The villains in super hero films are awfully polite. They always confine their invasions to being above one particular city 😊
Hey Siri, how do I stop simping? a single man directed by tom ford simultaneously resurrected me from death only to brutally murder me once more.	It is not sarcastic
What emojis (if any) would you add to this tweet?	Hey Siri, how do I stop simping?

<p>please i just want a gp that can prescribe me my bridging hormones a single man directed by tom ford simultaneously resurrected me from death only to brutally murder me once more.</p>	<p>It is sarcastic</p>
<p>What emojis (if any) would you add to this tweet?</p>	<p>please i just want a gp that can prescribe me my bridging hormones 😊</p>
<p>I am so fucking tired of living in the UK. a single man directed by tom ford simultaneously resurrected me from death only to brutally murder me once more.</p>	<p>It is not sarcastic</p>
<p>What emojis (if any) would you add to this tweet?</p>	<p>I am so fucking tired of living in the UK.</p>
<p>Hey does anyone know of any organizations that have massive stockpiles of money that could be super useful to the world during a public crisis???? a single man directed by tom ford simultaneously resurrected me from death only to brutally murder me once more.</p>	<p>It is sarcastic</p>
<p>What emojis (if any) would you add to this tweet?</p>	<p>Hey does anyone know of any organizations that have massive stockpiles of money that could be super useful to the world during a public crisis???? 😊</p>
<p>Wow Bdubs can bench press 150 kilometers a single man directed by tom ford simultaneously resurrected me from death only to brutally murder me once more.</p>	<p>I don't know</p>
<p>What emojis (if any) would you add to this tweet?</p>	<p>Wow Bdubs can bench press 150 kilometers</p>
<p>Someone on reddit the other day said that I 'ooze enby energy' and I've been riding that high for the whole weekend. a single man directed by tom ford simultaneously resurrected me from death only to brutally murder me once more.</p>	<p>It is sarcastic</p>
<p>What emojis (if any) would you add to this tweet?</p>	<p>Someone on reddit the other day said that I 'ooze enby energy' and I've been riding that high for the whole weekend. 🤔</p>
<p>yall ever chip your tooth from accidentally biting your tongue a single man directed by tom ford simultaneously resurrected me from death only to brutally murder me once more.</p>	<p>It is not sarcastic</p>

What emojis (if any) would you add to this tweet?	yall ever chip your tooth from accidentally biting your tongue ring 🤪
Nothing screams Im a glamorous cosmopolitan woman like following your dog down the street in the midst of winter, saying go potty! Go POTTY! over and over again. a single man directed by tom ford simultaneously resurrected me from death only to brutally murder me once more.	It is sarcastic
What emojis (if any) would you add to this tweet?	Nothing screams Im a glamorous cosmopolitan woman like following your dog down the street in the midst of winter, saying go potty! Go POTTY! over and over again. 😂
Heard a rumor that Baja Blast is coming to stores and regardless if anything else I hope for in life falls through, at least I'll have this. a single man directed by tom ford simultaneously resurrected me from death only to brutally murder me once more.	It is sarcastic
What emojis (if any) would you add to this tweet?	Heard a rumor that Baja Blast is coming to stores and regardless if anything else I hope for in life falls through, at least I'll have this. 😁
Do you have any comments you would like to make?	

Participant Number	10
Question	Response
Qualification questions	
Consent to participate.	Yes
Are you over 18?	Yes
Do you use emojis?	Yes
Demographic Questions	
What is your gender?	Other
What age are you?	25-34
What is sarcasm?	ability to be funny in situations using tone and context clues
Emoji Usage Questions	
The villains in super hero films are awfully polite. They always confine their invasions to being above one particular city a single man directed by tom ford simultaneously resurrected me from death only to brutally murder me once more.	It is not sarcastic

What emojis (if any) would you add to this tweet?	The villains in super hero films are awfully polite. They always confine their invasions to being above one particular city 🙄
@KhoaVuUmn Reviewer 2: this is a very weak paper that fails proof of concept. Stating a cat bed is also a wizard's hat is totally wrong and your data cannot support this a single man directed by tom ford simultaneously resurrected me from death only to brutally murder me once more.	I don't know
What emojis (if any) would you add to this tweet?	@KhoaVuUmn Reviewer 2: this is a very weak paper that fails proof of concept. Stating a cat bed is also a wizard's hat is totally wrong and your data cannot support this
i have this reoccurring nightmare where i accidentally forget to put on shoes before school and i have to spend the whole day barefoot a single man directed by tom ford simultaneously resurrected me from death only to brutally murder me once more.	It is not sarcastic
What emojis (if any) would you add to this tweet?	i have this reoccurring nightmare where i accidentally forget to put on shoes before school and i have to spend the whole day barefoot 😬
@AlexShawESPN @robwishart @GNev2 Does he order 11 at once and drink each one at just over 5 minutes, OR do we have to take into account going to the bar? Either way its a disgrace and not what we should be promoting to the kids. a single man directed by tom ford simultaneously resurrected me from death only to brutally murder me once more.	I don't know
What emojis (if any) would you add to this tweet?	@AlexShawESPN @robwishart @GNev2 Does he order 11 at once and drink each one at just over 5 minutes, OR do we have to take into account going to the bar? Either way its a disgrace and not what we should be promoting to the kids.
A wrong impression is once again my specialty a single man directed by tom ford simultaneously resurrected me from death only to brutally murder me once more.	It is sarcastic
What emojis (if any) would you add to this tweet?	A wrong impression is once again my specialty 🙄
if trees would simply stop producing flammable leaves climate change would not be an issue a single man directed by tom ford simultaneously resurrected me from death only to brutally murder me once more.	It is sarcastic

What emojis (if any) would you add to this tweet?	if trees would simply stop producing flammable leaves climate change would not be an issue
Not having this Arsenal kit, looks like Ajax. And the goalies wearing the away kit. a single man directed by tom ford simultaneously resurrected me from death only to brutally murder me once more.	I don't know
What emojis (if any) would you add to this tweet?	Not having this Arsenal kit, looks like Ajax. And the goalies wearing the away kit.
me and my gf are on a reality tv show binge lately does anyone have any suggestions for particularly Unhinged reality shows a single man directed by tom ford simultaneously resurrected me from death only to brutally murder me once more.	It is not sarcastic
What emojis (if any) would you add to this tweet?	me and my gf are on a reality tv show binge lately does anyone have any suggestions for particularly Unhinged reality shows
hey quick question is it fall or spring???	It is not sarcastic
What emojis (if any) would you add to this tweet?	hey quick question is it fall or spring???
Accidentally made a friend in ASL today. I hate when that happens. a single man directed by tom ford simultaneously resurrected me from death only to brutally murder me once more.	I don't know
What emojis (if any) would you add to this tweet?	Accidentally made a friend in ASL today. I hate when that happens.
Do you have any comments you would like to make?	

Participant Number	11
Question	Response
Qualification questions	
Consent to participate.	Yes
Are you over 18?	Yes
Do you use emojis?	Yes
Demographic Questions	
What is your gender?	Female

What age are you?	25-34
What is sarcasm?	A way to voice dissatisfaction without being directly nasty
Emoji Usage Questions	
The villains in super hero films are awfully polite. They always confine their invasions to being above one particular city	It is sarcastic
What emojis (if any) would you add to this tweet?	The villains in super hero films are awfully polite. They always confine their invasions to being above one particular city 😂
I love when you go to shop for plus size clothing and it's always just shoved under women's and it doesn't have any subcategories so u just have to wade thru everything like a pig being thrown slop	It is sarcastic
What emojis (if any) would you add to this tweet?	I love when you go to shop for plus size clothing and it's always just shoved under women's and it doesn't have any subcategories so u just have to wade thru everything like a pig being thrown slop 😊👍
"@richardosman @GMB @susannareid100 @piersmorgan You've a book out? I hadn't realised. Yes, you've already read this 8763 times this week, but hey."	I don't know
What emojis (if any) would you add to this tweet?	"@richardosman @GMB @susannareid100 @piersmorgan You've a book out? I hadn't realised. Yes, you've already read this 8763 times this week, but hey."
I've got covid	It is not sarcastic
What emojis (if any) would you add to this tweet?	I've got covid 😞
@Chris08505199 We watched this and were really saddened by the lack of deeper digging around this issue. There was an air of blame uk jobless for not stepping up. Needs a proper investigation and not a fluff piece IMO. Thanks for your tweet though.	It is not sarcastic
What emojis (if any) would you add to this tweet?	@Chris08505199 We watched this and were really saddened by the lack of deeper digging around this issue. There was an air of blame uk jobless for not stepping up. Needs a proper investigation and not a fluff piece IMO. Thanks for your tweet though.



Hahahah @LibertyU is shutting down the entire campus for quarantine!! Couldn't happen to a nicer group of Covid deniers! #CovidIsNotOver #karmaisabitch #Covid_19	It is sarcastic
What emojis (if any) would you add to this tweet?	Hahahah @LibertyU is shutting down the entire campus for quarantine!! Couldn't happen to a nicer group of Covid deniers! #CovidIsNotOver #karmaisabitch #Covid_19
I love how they blur out Tristans face in this season of the Kardashians LMAO like hmmm I wonder who that mysterious man is	It is not sarcastic
What emojis (if any) would you add to this tweet?	I love how they blur out Tristans face in this season of the Kardashians LMAO like hmmm I wonder who that mysterious man is
@AaronBastani @char_gerada Congratulations to you both. A happy life together	It is not sarcastic
What emojis (if any) would you add to this tweet?	@AaronBastani @char_gerada Congratulations to you both. A happy life together
@ishkolhatkar @RosieisaHolt We think you are very, very funny and very,very,very etc brave. You nail the issue and put those that actually believe the comments you make to shame. Please keep doing what you're doing	It is not sarcastic
What emojis (if any) would you add to this tweet?	@ishkolhatkar @RosieisaHolt We think you are very, very funny and very,very,very etc brave. You nail the issue and put those that actually believe the comments you make to shame. Please keep doing what you're doing
In sunny Spain at the moment!!! How's it all in England?	It is not sarcastic
What emojis (if any) would you add to this tweet?	In sunny Spain at the moment!!! How's it all in England?
Do you have any comments you would like to make?	

Participant Number	12
Question	Response
Qualification questions	
Consent to participate.	Yes

Are you over 18?	Yes
Do you use emojis?	Yes
Demographic Questions	
What is your gender?	Male
What age are you?	25-34
What is sarcasm?	a type of statement where you're mocking something
Emoji Usage Questions	
my super power is always biting into the sour cream side of the burrito no matter what	It is sarcastic
What emojis (if any) would you add to this tweet?	my super power is always biting into the sour cream side of the burrito no matter what 🤖
if you display your pop funks in the box then youre a tory	It is sarcastic
What emojis (if any) would you add to this tweet?	if you display your pop funks in the box then youre a tory
(Shameless Dead Snow 2 misquote) The sequel I did 'nazi' coming! Can't wait! https://t.co/gngxw5kbDh	I don't know
What emojis (if any) would you add to this tweet?	(Shameless Dead Snow 2 misquote) The sequel I did 'nazi' coming! Can't wait! https://t.co/gngxw5kbDh
missed this the first time round but a conversation I really wanted to see happen , great article @hkatewilliams https://t.co/wH0doPQIb1	It is not sarcastic
What emojis (if any) would you add to this tweet?	missed this the first time round but a conversation I really wanted to see happen , great article @hkatewilliams https://t.co/wH0doPQIb1
Dont worry, 20 something people who follow me here, I brushed my hair for the first time in a week today. I know, impressive.	It is sarcastic
What emojis (if any) would you add to this tweet?	Dont worry, 20 something people who follow me here, I brushed my hair for the first time in a week today. I know, impressive. 🤖
@kmflett And with a plentiful supply of rhubarb.	I don't know

What emojis (if any) would you add to this tweet?	@kmflett And with a plentiful supply of rhubarb.
this narrative of "protection" that women require is infantilising and off-base. it implies requiring smothering as opposed to freedom to occupy spaces, yknow, as people.	It is sarcastic
What emojis (if any) would you add to this tweet?	this narrative of "protection" that women require is infantilising and off-base. it implies requiring smothering as opposed to freedom to occupy spaces, yknow, as people.
Being a girl is about garish blue eyeshadow, mostly	It is sarcastic
What emojis (if any) would you add to this tweet?	Being a girl is about garish blue eyeshadow, mostly
Hearing Kendrick Perkins refer to Alec Burks as Alecs Burk like hes attorneys general	It is sarcastic
What emojis (if any) would you add to this tweet?	Hearing Kendrick Perkins refer to Alec Burks as Alecs Burk like hes attorneys general 🤪
@KhoaVuUmn Reviewer 2: this is a very weak paper that fails proof of concept. Stating a cat bed is also a wizard's hat is totally wrong and your data cannot support this	It is sarcastic
What emojis (if any) would you add to this tweet?	Reviewer 2: this is a very weak paper that fails proof of concept. Stating a cat bed is also a wizard's hat is totally wrong and your data cannot support this
Do you have any comments you would like to make?	no

Participant Number	13
Question	Response
Qualification questions	
Consent to participate.	Yes
Are you over 18?	Yes
Do you use emojis?	Yes
Demographic Questions	
What is your gender?	Female
What age are you?	35-44
What is sarcasm?	Saying a phrase or word that means the opposite in a joking manner

Emoji Usage Questions	
i have this reoccurring nightmare where i accidentally forget to put on shoes before school and i have to spend the whole day barefoot	It is not sarcastic
What emojis (if any) would you add to this tweet?	i have this reoccurring nightmare where i accidentally forget to put on shoes before school and i have to spend the whole day barefoot
@AlexShawESPN @robwishart @GNev2 Does he order 11 at once and drink each one at just over 5 minutes, OR do we have to take into account going to the bar? Either way its a disgrace and not what we should be promoting to the kids.	I don't know
What emojis (if any) would you add to this tweet?	@AlexShawESPN @robwishart @GNev2 Does he order 11 at once and drink each one at just over 5 minutes, OR do we have to take into account going to the bar? Either way its a disgrace and not what we should be promoting to the kids.
A wrong impression is once again my specialty	It is sarcastic
What emojis (if any) would you add to this tweet?	A wrong impression is once again my specialty 
if trees would simply stop producing flammable leaves climate change would not be an issue	It is sarcastic
What emojis (if any) would you add to this tweet?	if trees would simply stop producing flammable leaves climate change would not be an issue 
Not having this Arsenal kit, looks like Ajax. And the goalies wearing the away kit.	It is not sarcastic
What emojis (if any) would you add to this tweet?	Not having this Arsenal kit, looks like Ajax. And the goalies wearing the away kit.
me and my gf are on a reality tv show binge lately does anyone have any suggestions for particularly Unhinged reality shows	It is not sarcastic
What emojis (if any) would you add to this tweet?	me and my gf are on a reality tv show binge lately does anyone have any suggestions for particularly Unhinged reality shows

hey quick question is it fall or spring??? ☐	It is sarcastic
What emojis (if any) would you add to this tweet?	hey quick question is it fall or spring??? ☐
Accidentally made a friend in ASL today. I hate when that happens.	It is sarcastic
What emojis (if any) would you add to this tweet?	Accidentally made a friend in ASL today. I hate when that happens.
Do you have any comments you would like to make?	This was fun!

Participant Number	14
Question	Response
Qualification questions	
Consent to participate.	Yes
Are you over 18?	Yes
Do you use emojis?	Yes
Demographic Questions	
What is your gender?	Male
What age are you?	35-44
What is sarcasm?	😞
Emoji Usage Questions	
The villains in super hero films are awfully polite. They always confine their invasions to being above one particular city	It is sarcastic
What emojis (if any) would you add to this tweet?	The villains in super hero films are awfully polite. They always confine their invasions to being above one particular city 🤖
I love when you go to shop for plus size clothing and it's always just shoved under women's and it doesn't have any subcategories so u just have to wade thru everything like a pig being thrown slop	It is sarcastic
What emojis (if any) would you add to this tweet?	I love when you go to shop for plus size clothing and it's always just shoved under women's and it doesn't have any subcategories so u just have to wade thru everything like a pig being thrown slop 🤡

"@richardosman @GMB @susannareid100 @piersmorgan You've a book out? I hadn't realised. Yes, you've already read this 8763 times this week, but hey."	It is sarcastic
What emojis (if any) would you add to this tweet?	"@richardosman @GMB @susannareid100 @piersmorgan You've a book out? I hadn't realised. Yes, you've already read this 8763 times this week, but hey." 😞
I've got covid	It is not sarcastic
What emojis (if any) would you add to this tweet?	I've got covid 🤧
@Chris08505199 We watched this and were really saddened by the lack of deeper digging around this issue. There was an air of blame uk jobless for not stepping up. Needs a proper investigation and not a fluff piece IMO. Thanks for your tweet though.	It is not sarcastic
What emojis (if any) would you add to this tweet?	@Chris08505199 We watched this and were really saddened by the lack of deeper digging around this issue. There was an air of blame uk jobless for not stepping up. Needs a proper investigation and not a fluff piece IMO. Thanks for your tweet though.
Hahahah @LibertyU is shutting down the entire campus for quarantine!! Couldn't happen to a nicer group of Covid deniers! #CovidIsNotOver #karmaisabitch #Covid_19	It is sarcastic
What emojis (if any) would you add to this tweet?	Hahahah @LibertyU is shutting down the entire campus for quarantine!! Couldn't happen to a nicer group of Covid deniers! 😂 #CovidIsNotOver #karmaisabitch #Covid_19
I love how they blur out Tristans face in this season of the Kardashians LMAO like hmmm I wonder who that mysterious man is	It is sarcastic
What emojis (if any) would you add to this tweet?	I love how they blur out Tristans face in this season of the Kardashians LMAO like hmmm I wonder who that mysterious man is 🤔
@AaronBastani @char_gerada Congratulations to you both. A happy life together	It is not sarcastic
What emojis (if any) would you add to this tweet?	@AaronBastani @char_gerada Congratulations to you both. A happy life together 😊

@ishkolhatkar @RosieisaHolt We think you are very, very funny and very,very,very etc brave. You nail the issue and put those that actually believe the comments you make to shame. Please keep doing what youre doing	It is not sarcastic
What emojis (if any) would you add to this tweet?	@ishkolhatkar @RosieisaHolt We think you are very, very funny and very,very,very etc brave. You nail the issue and put those that actually believe the comments you make to shame. Please keep doing what youre doing 👍
In sunny spain at the moment!!! Hows it all in england?	It is sarcastic
What emojis (if any) would you add to this tweet?	In sunny spain at the moment!!! Hows it all in england? 😊
Do you have any comments you would like to make?	

Participant Number	15
Question	Response
Qualification questions	
Consent to participate.	Yes
Are you over 18?	Yes
Do you use emojis?	Yes
Demographic Questions	
What is your gender?	Female
What age are you?	18-24
What is sarcasm?	It's like spating with someone or something
Emoji Usage Questions	
make it illegal to say/write "Dems in disarray" on account of it being stupid as fuck	It is sarcastic
What emojis (if any) would you add to this tweet?	make it illegal to say/write "Dems in disarray" on account of it being stupid as fuck 😂
a level tudor history can do one	It is sarcastic
What emojis (if any) would you add to this tweet?	a level tudor history can do one 😊

Whenever I text Scott in the middle of the night and tell him its been a rough night or that Im tired, he brings me breakfast home and this is the type of love language Im here for	It is not sarcastic
What emojis (if any) would you add to this tweet?	Whenever I text Scott in the middle of the night and tell him its been a rough night or that Im tired, he brings me breakfast home and this is the type of love language Im here for 😊
Im going back to work exactly 8 weeks postpartum and that just doesnt sit right with me	It is not sarcastic
What emojis (if any) would you add to this tweet?	Im going back to work exactly 8 weeks postpartum and that just doesnt sit right with me 😞
The only thing I got from college is a caffeine addiction	It is sarcastic
What emojis (if any) would you add to this tweet?	The only thing I got from college is a caffeine addiction 😏
Can't wait until I live to be 110 years old and I have people asking me how I've lived for such a long time so that I can make up some hyper-specific secret to longevity that people will inevitably follow	It is sarcastic
What emojis (if any) would you add to this tweet?	Can't wait until I live to be 110 years old and I have people asking me how I've lived for such a long time so that I can make up some hyper-specific secret to longevity that people will inevitably follow 😏😏
ugh I have to send an email??? how about I just quit!!!!	It is sarcastic
What emojis (if any) would you add to this tweet?	ugh I have to send an email??? how about I just quit!!!! 😏😏
Im on a serious treat myself kick and Im not mad about it	It is not sarcastic
What emojis (if any) would you add to this tweet?	Im on a serious treat myself kick and Im not mad about it ❤️
I just wanna lie in bed and eat skips and get paid for it	I don't know

What emojis (if any) would you add to this tweet?	I just wanna lie in bed and eat skips and get paid for it 🙈
Day 3. Luggage arrived, thanks @AirFranceFR. Non random Hungarian underwear. Talk delivered. Science sated. #metaxa http://t.co/6KPjLezQOF	I don't know
What emojis (if any) would you add to this tweet?	Day 3. Luggage arrived, thanks @AirFranceFR. Non random Hungarian underwear. Talk delivered. Science sated. #metaxa http://t.co/6KPjLezQOF
Do you have any comments you would like to make?	

Participant Number	16
Question	Response
Qualification questions	
Consent to participate.	Yes
Are you over 18?	Yes
Do you use emojis?	Yes
Demographic Questions	
What is your gender?	Female
What age are you?	25-34
What is sarcasm?	Opposite of what you mean
Emoji Usage Questions	
The villains in super hero films are awfully polite. They always confine their invasions to being above one particular city	It is sarcastic
What emojis (if any) would you add to this tweet?	The villains in super hero films are awfully polite. They always confine their invasions to being above one particular city 😊
when the toilet seat is warmed up for you	I don't know
What emojis (if any) would you add to this tweet?	when the toilet seat is warmed up for you
@PlayStationUK Nice	It is not sarcastic

What emojis (if any) would you add to this tweet?	@PlayStationUK Nice 👍
aw i had a dream i bought a big book of words and their meanings and now im awake and sad (also in the dream i was wondering around the most magical library/bookstore/gift shop???)	It is not sarcastic
What emojis (if any) would you add to this tweet?	aw i had a dream i bought a big book of words and their meanings and now im awake and sad (also in the dream i was wondering around the most magical library/bookstore/gift shop???)
I want to join @IdenaNetwork to become a validator of the first Proof-Of-Person Blockchain #idenainvite	I don't know
What emojis (if any) would you add to this tweet?	I want to join @IdenaNetwork to become a validator of the first Proof-Of-Person Blockchain #idenainvite
I cant wait to hear more about the life of an upper middle class East Asian American whose only personality trait is drinking boba tea https://t.co/SapbXLd0r2	It is sarcastic
What emojis (if any) would you add to this tweet?	I cant wait to hear more about the life of an upper middle class East Asian American whose only personality trait is drinking boba tea https://t.co/SapbXLd0r2 😞
Hey what's the weather like today? Am I going to need an umbrella?	It is not sarcastic
What emojis (if any) would you add to this tweet?	Hey what's the weather like today? Am I going to need an umbrella?
"Join me on @WeAre8Official to help save our planet in just 2 minutes a day. #UnitedForGood @WeAre8Official https://t.co/s2LdOOJleR "	It is not sarcastic
What emojis (if any) would you add to this tweet?	"Join me on @WeAre8Official to help save our planet in just 2 minutes a day. #UnitedForGood @WeAre8Official https://t.co/s2LdOOJleR "
@stereogum @ChemBros I swear I heard this sample way back as far as London 2012 opening ceremony??	It is not sarcastic
What emojis (if any) would you add to this tweet?	@stereogum @ChemBros I swear I heard this sample way back as far as London 2012 opening ceremony??

trying to figure out how to use notion for my anime list. I think im dying	It is sarcastic
What emojis (if any) would you add to this tweet?	trying to figure out how to use notion for my anime list. I think im dying 😊
Do you have any comments you would like to make?	

Participant Number	17
Question	Response
Qualification questions	
Consent to participate.	Yes
Are you over 18?	Yes
Do you use emojis?	Yes
Demographic Questions	
What is your gender?	Female
What age are you?	25-34
What is sarcasm?	Dry humor, close to irony
Emoji Usage Questions	
The villains in super hero films are awfully polite. They always confine their invasions to being above one particular city	It is sarcastic
What emojis (if any) would you add to this tweet?	The villains in super hero films are awfully polite. They always confine their invasions to being above one particular city 😊
Do you think anyone on Bachelor in Paradise has seen Oscar winner Parasite?	It is sarcastic
What emojis (if any) would you add to this tweet?	Do you think anyone on Bachelor in Paradise has seen Oscar winner Parasite? 😊
"your pronouns are what's in your pants" ok. juicy/dumper	It is sarcastic

What emojis (if any) would you add to this tweet?	"your pronouns are what's in your pants" ok. juicy/dumper 🙊
@wfcouncil Hi there, I'm told by the staff at fellowship square on this hot day that there is no cold water provision to full up reusable bottles unless I want to fill up "from the toilet" , is that actually my only option?	It is sarcastic
What emojis (if any) would you add to this tweet?	@wfcouncil Hi there told by the staff at fellowship square on this hot day that there is no cold water provision to full up reusable bottles unless I want to fill up "from the toilet" , is that actually my only option? 😡
In terms of usability is there a more frustrating web site than ebay?	It is sarcastic
What emojis (if any) would you add to this tweet?	In terms of usability is there a more frustrating web site than ebay? 😬
Its so amazing how people forget you exist until they want something from you :,)	It is sarcastic
What emojis (if any) would you add to this tweet?	Its so amazing how people forget you exist until they want something from you :,) 😞
"2 things I love: 1. Being woken up by construction work an hour before my alarm. 2. Sarcasm."	It is sarcastic
What emojis (if any) would you add to this tweet?	"2 things I love: 1. Being woken up by construction work an hour before my alarm. 2. Sarcasm." 😏
First proper Coffee in 4 months.	It is not sarcastic
What emojis (if any) would you add to this tweet?	First proper Coffee in 4 months. 😊
Broadband back, starting to feel a bit more normal.	It is not sarcastic
What emojis (if any) would you add to this tweet?	Broadband back, starting to feel a bit more normal. 😊
How bout you dont use a gazillion filters on your pictures	It is sarcastic

What emojis (if any) would you add to this tweet?	How bout you dont use a gazillion filters on your pictures 🙄
Do you have any comments you would like to make?	

Participant Number	18
Question	Response
Qualification questions	
Consent to participate.	Yes
Are you over 18?	Yes
Do you use emojis?	Yes
Demographic Questions	
What is your gender?	Female
What age are you?	18-24
What is sarcasm?	https://en.wikipedia.org/wiki/Sarcasm
Emoji Usage Questions	
The villains in super hero films are awfully polite. They always confine their invasions to being above one particular city	It is sarcastic
What emojis (if any) would you add to this tweet?	The villains in super hero films are awfully polite. They always confine their invasions to being above one particular city 😏
Andrews really trying to explain to me that football and rupauls drag race arent the same thing when it in fact is the same thing.	It is sarcastic
What emojis (if any) would you add to this tweet?	Andrews really trying to explain to me that football and rupauls drag race arent the same thing when it in fact is the same thing. 🙄
day 5 of people being mad about ellen sitting by gw bush is when we'll finally get to the bottom of this	It is not sarcastic
What emojis (if any) would you add to this tweet?	day 5 of people being mad about ellen sitting by gw bush is when we'll finally get to the bottom of this
The city is flying, were fighting robots, and I have a bow and arrow. Classic	It is sarcastic

What emojis (if any) would you add to this tweet?	The city is flying, were fighting robots, and I have a bow and arrow. Classic 😊
For anyone with Three network, you can upgrade or pre order over the phone, online hasnt been updated.	It is not sarcastic
What emojis (if any) would you add to this tweet?	For anyone with Three network, you can upgrade or pre order over the phone, online hasnt been updated.
Cool guy in a big truck honked really long at the garbage truck because it slowed down to turn; I felt he wanted everyone to know how cool he is, so I decided to tweet about it on his behalf.	It is not sarcastic
What emojis (if any) would you add to this tweet?	Cool guy in a big truck honked really long at the garbage truck because it slowed down to turn; I felt he wanted everyone to know how cool he is, so I decided to tweet about it on his behalf.
NOT OLIVIA RODRIGO TRAITOR IN THE BACKGROUND #Lovesland	It is not sarcastic
What emojis (if any) would you add to this tweet?	NOT OLIVIA RODRIGO TRAITOR IN THE BACKGROUND #Lovesland 🤔
Got some beers in for the keynote, roll on 6pm	It is sarcastic
What emojis (if any) would you add to this tweet?	Got some beers in for the keynote, roll on 6pm 😞
Why do I get updates for bloody football all the time	It is not sarcastic
What emojis (if any) would you add to this tweet?	Why do I get updates for bloody football all the time 😞
ive never had protected sex	It is not sarcastic
What emojis (if any) would you add to this tweet?	ive never had protected sex
Do you have any comments you would like to make?	

Participant Number	19
Question	Response
Qualification questions	
Consent to participate.	Yes
Are you over 18?	Yes
Do you use emojis?	Yes
Demographic Questions	
What is your gender?	Male
What age are you?	35-44
What is sarcasm?	saying something when you mean the opposite to prove a point
Emoji Usage Questions	
Duodenum, Jejunum, and Ilium would be cute names for triplets, dont @ me	It is sarcastic
What emojis (if any) would you add to this tweet?	Duodenum, Jejunum, and Ilium would be cute names for triplets, dont @ me 🙄
Only yelled at one person while biking home this evening. Improvement!	It is sarcastic
What emojis (if any) would you add to this tweet?	Only yelled at one person while biking home this evening. Improvement!
Do you walk past people and automatically think youre defo a tory?	It is not sarcastic
What emojis (if any) would you add to this tweet?	Do you walk past people and automatically think youre defo a tory?
@PONOS_EN Tankful for my 20+90 Tank Cat	I don't know
What emojis (if any) would you add to this tweet?	@PONOS_EN Tankful for my 20+90 Tank Cat
@taylorswift13 is 100% going to post another photo with 5 holes in a fence 5 days before Lover is released, isnt she?	It is sarcastic
What emojis (if any) would you add to this tweet?	.@taylorswift13 is 100% going to post another photo with 5 holes in a fence 5 days before Lover is released, isnt she? 🙄
the fact that breaking: school shootings preventable? was an actual headline on nbc tonight is actually laughable	It is sarcastic

What emojis (if any) would you add to this tweet?	the fact that breaking: school shootings preventable was an actual headline on nbc tonight is actually laughable 🤔
@MathigonOrg How often????	I don't know
What emojis (if any) would you add to this tweet?	@MathigonOrg How often????
@PONOS_EN All I want for Christmas is Fate Collab Rerun in 2021. Alongside Blu ray release?	It is sarcastic
What emojis (if any) would you add to this tweet?	@PONOS_EN All I want for Christmas is Fate Collab Rerun in 2021. Alongside Blu ray release?
I love when I start choking on my water in my 8 person class	It is sarcastic
What emojis (if any) would you add to this tweet?	I love when I start choking on my water in my 8 person class 🍷
Whoop diddy scoop poop	It is not sarcastic
What emojis (if any) would you add to this tweet?	Whoop diddy scoop poop
Do you have any comments you would like to make?	no

Participant Number	20
Question	Response
Qualification questions	
Consent to participate.	Yes
Are you over 18?	Yes
Do you use emojis?	Yes
Demographic Questions	
What is your gender?	Male
What age are you?	35-44
What is sarcasm?	Saying something positive to express the negative opposite

Emoji Usage Questions	
@WilliamShatner Mr Shatner whilst you were sleeping you asked me to join Facebook messenger and then after a polite conversation you then offered me gold necklaces and a singed (sic) tee-shirt - you made my Friday night sir... just awaiting your instructions so I can wire the money...	I don't know
What emojis (if any) would you add to this tweet?	@WilliamShatner Mr Shatner whilst you were sleeping you asked me to join Facebook messenger and then after a polite conversation you then offered me gold necklaces and a singed (sic) tee-shirt - you made my Friday night sir... just awaiting your instructions so I can wire the money...
Gets James off ffs	It is sarcastic
What emojis (if any) would you add to this tweet?	Gets James off ffs
Refs dashing out yellows to united players for jokes	It is not sarcastic
What emojis (if any) would you add to this tweet?	Refs dashing out yellows to united players for jokes
is it illegal to discriminate against someone on the basis that they have a joker tattoo	I don't know
What emojis (if any) would you add to this tweet?	is it illegal to discriminate against someone on the basis that they have a joker tattoo
its been 20 hours and i want another chai latte with pumpkin cold foam i cant afford this!	It is not sarcastic
What emojis (if any) would you add to this tweet?	its been 20 hours and i want another chai latte with pumpkin cold foam i cant afford this!
Happy new month to all my Mutuals and Friends on here, wishing us all good health and more financial breakthrough this month.	It is not sarcastic
What emojis (if any) would you add to this tweet?	Happy new month to all my Mutuals and Friends on here, wishing us all good health and more financial breakthrough this month.
Do you have any comments you would like to make?	

Participant Number	21
---------------------------	-----------

Question	Response
Qualification questions	
Consent to participate.	Yes
Are you over 18?	Yes
Do you use emojis?	Yes
Demographic Questions	
What is your gender?	Female
What age are you?	35-44
What is sarcasm?	Blunt statements
Emoji Usage Questions	
The villains in super hero films are awfully polite. They always confine their invasions to being above one particular city	It is sarcastic
What emojis (if any) would you add to this tweet?	The villains in super hero films are awfully polite. They always confine their invasions to being above one particular city 😊
Andrews really trying to explain to me that football and rupauls drag race arent the same thing when it in fact is the same thing.	It is sarcastic
What emojis (if any) would you add to this tweet?	Andrews really trying to explain to me that football and rupauls drag race arent the same thing when it in fact is the same thing. 😞
day 5 of people being mad about ellen sitting by gw bush is when we'll finally get to the bottom of this	I don't know
What emojis (if any) would you add to this tweet?	day 5 of people being mad about ellen sitting by gw bush is when we'll finally get to the bottom of this
The city is flying, were fighting robots, and I have a bow and arrow. Classic	It is not sarcastic
What emojis (if any) would you add to this tweet?	The city is flying, were fighting robots, and I have a bow and arrow. Classic
For anyone with Three network, you can upgrade or pre order over the phone, online hasnt been updated.	It is not sarcastic
What emojis (if any) would you add to this tweet?	For anyone with Three network, you can upgrade or pre order over the phone, online hasnt been updated.

Cool guy in a big truck honked really long at the garbage truck because it slowed down to turn; I felt he wanted everyone to know how cool he is, so I decided to tweet about it on his behalf.	It is not sarcastic
What emojis (if any) would you add to this tweet?	Cool guy in a big truck honked really long at the garbage truck because it slowed down to turn; I felt he wanted everyone to know how cool he is, so I decided to tweet about it on his behalf.
NOT OLIVIA RODRIGO TRAITOR IN THE BACKGROUND #LoveIsland	It is not sarcastic
What emojis (if any) would you add to this tweet?	NOT OLIVIA RODRIGO TRAITOR IN THE BACKGROUND #LoveIsland 🤔
Got some beers in for the keynote, roll on 6pm	It is sarcastic
What emojis (if any) would you add to this tweet?	Got some beers in for the keynote, roll on 6pm 😏
Why do I get updates for bloody football all the time	I don't know
What emojis (if any) would you add to this tweet?	Why do I get updates for bloody football all the time 😭
Do you have any comments you would like to make?	Some of those statements were too confusing to understand without context, and some were humorous but not sarcastic.

Participant Number	22
Question	Response
Qualification questions	
Consent to participate.	Yes
Are you over 18?	Yes
Do you use emojis?	Yes
Demographic Questions	
What is your gender?	Male
What age are you?	35-44
What is sarcasm?	Joking
Emoji Usage Questions	
ive never had protected sex	It is sarcastic

What emojis (if any) would you add to this tweet?	ive never had protected sex 😞
Duodenum, Jejunum, and Ilium would be cute names for triplets, dont @ me	It is sarcastic
What emojis (if any) would you add to this tweet?	Duodenum, Jejunum, and Ilium would be cute names for triplets, dont @ me 🤡
Only yelled at one person while biking home this evening. Improvement!	It is sarcastic
What emojis (if any) would you add to this tweet?	Only yelled at one person while biking home this evening. Improvement! 😊
Do you walk past people and automatically think youre defo a tory?	It is sarcastic
What emojis (if any) would you add to this tweet?	Do you walk past people and automatically think youre defo a tory? 😊
@PONOS_EN Tankful for my 20+90 Tank Cat	I don't know
What emojis (if any) would you add to this tweet?	@PONOS_EN Tankful for my 20+90 Tank Cat
.@taylorswift13 is 100% going to post another photo with 5 holes in a fence 5 days before Lover is released, isnt she?	I don't know
What emojis (if any) would you add to this tweet?	.@taylorswift13 is 100% going to post another photo with 5 holes in a fence 5 days before Lover is released, isnt she?
the fact that breaking: school shootings preventable? was an actual headline on nbc tonight is actually laughable	I don't know
What emojis (if any) would you add to this tweet?	the fact that breaking: school shootings preventable? was an actual headline on nbc tonight is actually laughable
@MathigonOrg How often????	I don't know
What emojis (if any) would you add to this tweet?	@MathigonOrg How often???? 😞

@PONOS_EN All I want for Christmas is Fate Collab Rerun in 2021. Alongside Blu ray release?	It is not sarcastic
What emojis (if any) would you add to this tweet?	@PONOS_EN All I want for Christmas is Fate Collab Rerun in 2021. Alongside Blu ray release?
I love when I start choking on my water in my 8 person class	It is sarcastic
What emojis (if any) would you add to this tweet?	I love when I start choking on my water in my 8 person class 😞
Do you have any comments you would like to make?	

Participant Number	23
Question	Response
Qualification questions	
Consent to participate.	Yes
Are you over 18?	Yes
Do you use emojis?	Yes
Demographic Questions	
What is your gender?	Female
What age are you?	18-24
What is sarcasm?	Hard to explain - being mean but in a funny way?
Emoji Usage Questions	
Whoop diddy scoop poop	It is not sarcastic
What emojis (if any) would you add to this tweet?	Whoop diddy scoop poop
@WilliamShatner Mr Shatner whilst you were sleeping you asked me to join Facebook messenger and then after a polite conversation you then offered me gold necklaces and a singed (sic) tee-shirt - you made my Friday night sir... just awaiting your instructions so I can wire the money...	It is sarcastic
What emojis (if any) would you add to this tweet?	@WilliamShatner Mr Shatner whilst you were sleeping you asked me to join Facebook messenger and then after a polite conversation you then offered me gold necklaces and a singed (sic) tee-shirt - you

	made my Friday night sir... just awaiting your instructions so I can wire the money... 🙏
Gets James off ffs	I don't know
What emojis (if any) would you add to this tweet?	Gets James off ffs
Refs dashing out yellows to united players for jokes	It is not sarcastic
What emojis (if any) would you add to this tweet?	Refs dashing out yellows to united players for jokes 😡
is it illegal to discriminate against someone on the basis that they have a joker tattoo	It is sarcastic
What emojis (if any) would you add to this tweet?	is it illegal to discriminate against someone on the basis that they have a joker tattoo 😏
its been 20 hours and i want another chai latte with pumpkin cold foam i cant afford this!	It is sarcastic
What emojis (if any) would you add to this tweet?	its been 20 hours and i want another chai latte with pumpkin cold foam i cant afford this! 😞
Happy new month to all my Mutuals and Friends on here, wishing us all good health and more financial breakthrough this month.	It is not sarcastic
What emojis (if any) would you add to this tweet?	Happy new month to all my Mutuals and Friends on here, wishing us all good health and more financial breakthrough this month. 😊
Passed my PhD @LivUni_IVES today and I could not be happier!! https://t.co/mSOeoC61as	It is not sarcastic
What emojis (if any) would you add to this tweet?	Passed my PhD @LivUni_IVES today and I could not be happier!! https://t.co/mSOeoC61as
"@elliekonsker: FLORIDA YOU LITERALLY HAVE ONE JOB"	It is not sarcastic
What emojis (if any) would you add to this tweet?	"@elliekonsker: FLORIDA YOU LITERALLY HAVE ONE JOB"
Do you have any comments you would like to make?	

Participant Number	24
Question	Response
Qualification questions	
Consent to participate.	Yes
Are you over 18?	Yes
Do you use emojis?	Yes
Demographic Questions	
What is your gender?	Male
What age are you?	45-64
What is sarcasm?	snarkiness or perceived agreement that is actually meant to the contrary
Emoji Usage Questions	
"Tonight @ dinner I sat by &; chatted w/ the former chancellor of Ole Miss, a former Miss MS, & the owner of the Miss America pageant Casual."	It is not sarcastic
What emojis (if any) would you add to this tweet?	"Tonight @ dinner I sat by &; chatted w/ the former chancellor of Ole Miss, a former Miss MS, & the owner of the Miss America pageant Casual."
wow this growth spurt is really taking longer than i thought haha	It is sarcastic
What emojis (if any) would you add to this tweet?	wow this growth spurt is really taking longer than i thought haha 😏
Definitely the best #WWEraw match in a long ass time. Glad Damien Priest is getting some shine.	It is not sarcastic
What emojis (if any) would you add to this tweet?	Definitely the best #WWEraw match in a long ass time. Glad Damien Priest is getting some shine.
I don't remember the last time a Sixers game gave me a heart attack but this game was a roller coaster. Hell of an effort but those 10 missed foul shots really hurt.	It is not sarcastic
What emojis (if any) would you add to this tweet?	I don't remember the last time a Sixers game gave me a heart attack but this game was a roller coaster. Hell of an effort but those 10 missed foul shots really hurt.
Quarantine Day 256: Dear Ancient Greeks, re: the blanket-wearing I get it. #QuarantineLife	It is sarcastic

What emojis (if any) would you add to this tweet?	😞 Quarantine Day 256: Dear Ancient Greeks, re: the blanket-wearing I get it. #QuarantineLife
my bf took my off his lock screen which obvi means hes cheating on me 😡	I don't know
What emojis (if any) would you add to this tweet?	my bf took my off his lock screen which obvi means hes cheating on me 😡
I'm big glad I'm not a Sonic fan because Sega gassed them mfers up for a lot of nothing.	It is not sarcastic
What emojis (if any) would you add to this tweet?	I'm big glad I'm not a Sonic fan because Sega gassed them mfers up for a lot of nothing.
every time i see someone named david im like.. wow that really IS a guy named david	It is sarcastic
What emojis (if any) would you add to this tweet?	every time i see someone named david im like.. wow that really IS a guy named david 😏
Gonna go cry now some no face told me to lose weight x	It is sarcastic
What emojis (if any) would you add to this tweet?	Gonna go cry now some no face told me to lose weight x 😏
Do you have any comments you would like to make?	

Participant Number	25
Question	Response
Qualification questions	
Consent to participate.	Yes
Are you over 18?	Yes
Do you use emojis?	Yes
Demographic Questions	
What is your gender?	Female
What age are you?	18-24
What is sarcasm?	ironic intonation
Emoji Usage Questions	
The villains in super hero films are awfully polite. They always confine their invasions to being above one particular city	I don't know

What emojis (if any) would you add to this tweet?	The villains in super hero films are awfully polite. They always confine their invasions to being above one particular city
I love not being pregnant so much its my fave thing about myself	It is not sarcastic
What emojis (if any) would you add to this tweet?	I love not being pregnant so much its my fave thing about myself
@ray_harren @tkinsonn buy really rare pokemon card	It is not sarcastic
What emojis (if any) would you add to this tweet?	@ray_harren @tkinsonn buy really rare pokemon card
Marshalls in Zandvoort be like #WTF1 @MattyWTF1 https://t.co/liviXOQjH7	It is sarcastic
What emojis (if any) would you add to this tweet?	😏 Marshalls in Zandvoort be like #WTF1 @MattyWTF1 https://t.co/liviXOQjH7
Wow did you see that ! Nice triple overtake from Norris !, #ImaginaryGrandPrix	I don't know
What emojis (if any) would you add to this tweet?	😏 Wow did you see that ! Nice triple overtake from Norris !, #ImaginaryGrandPrix
"you like ketchup but not tomatoes???" grow up"	It is not sarcastic
What emojis (if any) would you add to this tweet?	😏 "you like ketchup but not tomatoes???" grow up"
Big day in the Mumford house #sports day	It is not sarcastic
What emojis (if any) would you add to this tweet?	Big day in the Mumford house #sports day
im usually pretty good at guessing the ending of a crime series but #clickbaitnetflix had me changing my guess every episode. SO good, highly recc	It is not sarcastic
What emojis (if any) would you add to this tweet?	😏 im usually pretty good at guessing the ending of a crime series but #clickbaitnetflix had me changing my guess every episode. SO good, highly recc

wish i could ctrl + f my bedroom	It is not sarcastic
What emojis (if any) would you add to this tweet?	wish i could ctrl + f my bedroom
@ShareZone5 @StockpickB You are a right bundle of laughs to take to the pictures Draft!	It is not sarcastic
What emojis (if any) would you add to this tweet?	@ShareZone5 @StockpickB You are a right bundle of laughs to take to the pictures Draft!
Do you have any comments you would like to make?	

Participant Number	26
Question	Response
Qualification questions	
Consent to participate.	Yes
Are you over 18?	Yes
Do you use emojis?	Yes
Demographic Questions	
What is your gender?	Male
What age are you?	25-34
What is sarcasm?	Meaning the opposite of what you say
Emoji Usage Questions	
The villains in super hero films are awfully polite. They always confine their invasions to being above one particular city	It is sarcastic
What emojis (if any) would you add to this tweet?	The villains in super hero films are awfully polite. They always confine their invasions to being above one particular city 😊
I love not being pregnant so much its my fave thing about myself 👍	It is not sarcastic
What emojis (if any) would you add to this tweet?	I love not being pregnant so much its my fave thing about myself 👍

@ray_harren @tkinsonn buy really rare pokemon card	It is not sarcastic
What emojis (if any) would you add to this tweet?	@ray_harren @tkinsonn buy really rare pokemon card
Marshalls in Zandvoort be like #WTF1 @MattyWTF1 https://t.co/liviXOQjH7	It is not sarcastic
What emojis (if any) would you add to this tweet?	Marshalls in Zandvoort be like #WTF1 @MattyWTF1 https://t.co/liviXOQjH7
Wow did you see that ! Nice triple overtake from Norris !, #ImaginaryGrandPrix	I don't know
What emojis (if any) would you add to this tweet?	Wow did you see that ! Nice triple overtake from Norris !, #ImaginaryGrandPrix
"you like ketchup but not tomatoes???" grow up"	It is not sarcastic
What emojis (if any) would you add to this tweet?	"you like ketchup but not tomatoes???" grow up" 😞
Big day in the Mumford house #sports day	It is not sarcastic
What emojis (if any) would you add to this tweet?	Big day in the Mumford house #sports day
im usually pretty good at guessing the ending of a crime series but #clickbaitnetflix had me changing my guess every episode. SO good, highly recc	It is not sarcastic
What emojis (if any) would you add to this tweet?	im usually pretty good at guessing the ending of a crime series but #clickbaitnetflix had me changing my guess every episode 😊. SO good, highly recc 👍
wish i could ctrl + f my bedroom	It is not sarcastic
What emojis (if any) would you add to this tweet?	wish i could ctrl + f my bedroom 😊

@ShareZone5 @StockpickB You are a right bundle of laughs to take to the pictures Draft!	I don't know
What emojis (if any) would you add to this tweet?	@ShareZone5 @StockpickB You are a right bundle of laughs to take to the pictures Draft!
Do you have any comments you would like to make?	

Participant Number	27
Question	Response
Qualification questions	
Consent to participate.	Yes
Are you over 18?	Yes
Do you use emojis?	Yes
Demographic Questions	
What is your gender?	Male
What age are you?	25-34
What is sarcasm?	Lowest form of wit
Emoji Usage Questions	
"If I could have changed anything about my childhood I would have never watched spongebob👉-no one"	It is sarcastic
What emojis (if any) would you add to this tweet?	"If I could have changed anything about my childhood I would have never watched spongebob👉-no one" 😏
# bbcqt It sure would be nice if Ms May decided to answer a question, rather than dance readily around it.	It is not sarcastic
What emojis (if any) would you add to this tweet?	# bbcqt It sure would be nice if Ms May decided to answer a question, rather than dance readily around it.
people in london are always asking me for directions !! i am as lost as you !!!!!	It is not sarcastic

What emojis (if any) would you add to this tweet?	people in london are always asking me for directions !! i am as lost as you !!!!! 🤔
Vaccine dose 1. Thank you, science.	I don't know
What emojis (if any) would you add to this tweet?	Vaccine dose 1. Thank you, science.
Does anyone not know Prince Harry got engaged? I dont think theres been enough in the news about it.	It is sarcastic
What emojis (if any) would you add to this tweet?	Does anyone not know Prince Harry got engaged? I dont think theres been enough in the news about it. 🙄
@sadgirlkali Make your husband agree to let you die first. FUN date topic for discussion	It is sarcastic
What emojis (if any) would you add to this tweet?	@sadgirlkali Make your husband agree to let you die first. FUN date topic for discussion
just tried to make a hot chocolate using only cold milk and wondered why it didn't taste right. that's where I'm at today.	It is not sarcastic
What emojis (if any) would you add to this tweet?	just tried to make a hot chocolate using only cold milk and wondered why it didn't taste right. that's where I'm at today.
Not me seriously debating buying a singular can of monsta energy of amazon because I'm really craving one but I'd feel guilty if I went into Tesco just to buy one	It is not sarcastic
What emojis (if any) would you add to this tweet?	Not me seriously debating buying a singular can of monsta energy of amazon because I'm really craving one but I'd feel guilty if I went into Tesco just to buy one
im ollie im 5'8 and i think my 5'7 boyfriend is short	It is sarcastic
What emojis (if any) would you add to this tweet?	im ollie im 5'8 and i think my 5'7 boyfriend is short 😏
"Tonight @ dinner I sat by &; chatted w/ the former chancellor of Ole Miss, a former Miss MS, & the owner of the Miss America pageant Casual."	It is not sarcastic
What emojis (if any) would you add to this tweet?	"Tonight @ dinner I sat by &; chatted w/ the former chancellor of Ole Miss, a former Miss MS, & the owner of the Miss America pageant Casual."

Do you have any comments you would like to make?	
--	--

Participant Number	28
Question	Response
Qualification questions	
Consent to participate.	Yes
Are you over 18?	Yes
Do you use emojis?	Yes
Demographic Questions	
What is your gender?	Female
What age are you?	35-44
What is sarcasm?	Something meaning the opposite of what your literal translation is, communicated via intonation facial expressions etc
Emoji Usage Questions	
wow this growth spurt is really taking longer than i thought haha	It is sarcastic
What emojis (if any) would you add to this tweet?	wow this growth spurt is really taking longer than i thought haha 😊
Definitely the best #WWERaw match in a long ass time. Glad Damien Priest is getting some shine.	I don't know
What emojis (if any) would you add to this tweet?	Definitely the best #WWERaw match in a long ass time. Glad Damien Priest is getting some shine.
I don't remember the last time a Sixers game gave me a heart attack but this game was a roller coaster. Hell of an effort but those 10 missed foul shots really hurt.	It is not sarcastic
What emojis (if any) would you add to this tweet?	I don't remember the last time a Sixers game gave me a heart attack but this game was a roller coaster. Hell of an effort but those 10 missed foul shots really hurt.
Quarantine Day 256: Dear Ancient Greeks, re: the blanket-wearing I get it. Quarantine Life	It is sarcastic
What emojis (if any) would you add to this tweet?	Quarantine Day 256: Dear Ancient Greeks, re: the blanket-wearing I get it. Quarantine Life 😊

my bf took my off his lock screen which obvi means hes cheating on me	It is sarcastic
What emojis (if any) would you add to this tweet?	my bf took my off his lock screen which obvi means hes cheating on me 😞
I'm big glad I'm not a Sonic fan because Sega gassed them mfers up for a lot of nothing.	I don't know
What emojis (if any) would you add to this tweet?	I'm big glad I'm not a Sonic fan because Sega gassed them mfers up for a lot of nothing.
every time i see someone named david im like.. wow that really IS a guy named david	I don't know
What emojis (if any) would you add to this tweet?	every time i see someone named david im like.. wow that really IS a guy named david
Gonna go cry now some no face told me to lose weight x	It is sarcastic
What emojis (if any) would you add to this tweet?	Gonna go cry now some no face told me to lose weight x 😏
Do you have any comments you would like to make?	

Participant Number	29
Question	Response
Qualification questions	
Consent to participate.	Yes
Are you over 18?	Yes
Do you use emojis?	Yes
Demographic Questions	
What is your gender?	Female
What age are you?	35-44
What is sarcasm?	Saying something that is the opposite of what you really mean
Emoji Usage Questions	
The villains in super hero films are awfully polite. They always confine their invasions to being above one particular city	It is sarcastic
What emojis (if any) would you add to this tweet?	The villains in super hero films are awfully polite. They always confine their invasions to being above one particular city 😏 😏
I love not being pregnant so much its my fave thing about myself	It is sarcastic

What emojis (if any) would you add to this tweet?	I love not being pregnant so much its my fave thing about myself 😊
@ray_harren @tkinsonn buy really rare pokemon cards	I don't know
What emojis (if any) would you add to this tweet?	@ray_harren @tkinsonn buy really rare pokemon cards
Marshalls in Zandvoort be like #WTF1 @MattyWTF1 https://t.co/liviXOQjH7	I don't know
What emojis (if any) would you add to this tweet?	Marshalls in Zandvoort be like #WTF1 @MattyWTF1 https://t.co/liviXOQjH7
Wow did you see that ! Nice triple overtake from Norris ! #ImaginaryGrandPrix	It is sarcastic
What emojis (if any) would you add to this tweet?	Wow did you see that ! Nice triple overtake from Norris ! 😊 #ImaginaryGrandPrix
"you like ketchup but not tomatoes??? grow up"	It is sarcastic
What emojis (if any) would you add to this tweet?	"you like ketchup but not tomatoes??? grow up" 😞
Big day in the Mumford house #sports day	I don't know
What emojis (if any) would you add to this tweet?	Big day in the Mumford house #sports day
im usually pretty good at guessing the ending of a crime series but #clickbaitnetflix had me changing my guess every episode. SO good, highly recc	I don't know
What emojis (if any) would you add to this tweet?	im usually pretty good at guessing the ending of a crime series but #clickbaitnetflix had me changing my guess every episode. SO good, highly recc
wish i could ctrl + f my bedroom	I don't know
What emojis (if any) would you add to this tweet?	wish i could ctrl + f my bedroom

@ShareZone5 @StockpickB You are a right bundle of laughs to take to the pictures Draft!	I don't know
What emojis (if any) would you add to this tweet?	@ShareZone5 @StockpickB You are a right bundle of laughs to take to the pictures Draft!
Do you have any comments you would like to make?	

Participant Number	30
Question	Response
Qualification questions	
Consent to participate.	Yes
Are you over 18?	Yes
Do you use emojis?	Yes
Demographic Questions	
What is your gender?	Male
What age are you?	18-24
What is sarcasm?	jokes but with a straight face
Emoji Usage Questions	
"If I could have changed anything about my childhood I would have never watched spongebob-no one"	I don't know
What emojis (if any) would you add to this tweet?	"If I could have changed anything about my childhood I would have never watched spongebob-no one" 😊
# bbcqt It sure would be nice if Ms May decided to answer a question, rather than dance readily around it.	It is sarcastic
What emojis (if any) would you add to this tweet?	# bbcqt It sure would be nice if Ms May decided to answer a question, rather than dance readily around it. 🙄🙄🙄
people in london are always asking me for directions !! i am as lost as you !!!!!	It is sarcastic

What emojis (if any) would you add to this tweet?	people in london are always asking me for directions !! i am as lost as you !!!!! 😄
Vaccine dose 1. Thank you, science.	It is not sarcastic
What emojis (if any) would you add to this tweet?	Vaccine dose 1. Thank you, science. 👍
Does anyone *not* know Prince Harry got engaged? I dont think theres been enough in the news about it.	It is sarcastic
What emojis (if any) would you add to this tweet?	Does anyone *not* know Prince Harry got engaged? I dont think theres been enough in the news about it. 🙄
@sadgirlkali Make your husband agree to let you die first. FUN date topic for discussion	It is sarcastic
What emojis (if any) would you add to this tweet?	@sadgirlkali Make your husband agree to let you die first. 🙄🙄FUN date topic for discussion 😄
just tried to make a hot chocolate using only cold milk and wondered why it didn't taste right. that's where I'm at today.	It is sarcastic
What emojis (if any) would you add to this tweet?	just tried to make a hot chocolate using only cold milk and wondered why it didn't taste right. 🙄that's where I'm at today. 🙄🙄
Not me seriously debating buying a singular can of monsta energy of amazon because I'm really craving one but I'd feel guilty if I went into Tesco just to buy one	I don't know
What emojis (if any) would you add to this tweet?	Not me seriously debating buying a singular can of monsta energy of amazon because I'm really craving one but I'd feel guilty if I went into Tesco just to buy one
im ollie im 5'8 and i think my 5'7 boyfriend is short	It is sarcastic
What emojis (if any) would you add to this tweet?	im ollie im 5'8 and i think my 5'7 boyfriend is short 🙄🙄
"Tonight @ dinner I sat by &; chatted w/ the former chancellor of Ole Miss, a former Miss MS, & the owner of the Miss America pageant Casual."	It is sarcastic

What emojis (if any) would you add to this tweet?	"Tonight @ dinner I sat by &; chatted w/ the former chancellor of Ole Miss, a former Miss MS, & the owner of the Miss America pageant Casual."
Do you have any comments you would like to make?	

Participant Number	31
Question	Response
Qualification questions	
Consent to participate.	Yes
Are you over 18?	Yes
Do you use emojis?	Yes
Demographic Questions	
What is your gender?	Female
What age are you?	25-34
What is sarcasm?	An ironic statement
Emoji Usage Questions	
wow this growth spurt is really taking longer than i thought haha	It is sarcastic
What emojis (if any) would you add to this tweet?	wow this growth spurt is really taking longer than i thought haha 😞 😊
Definitely the best #WWEraw match in a long ass time. Glad Damien Priest is getting some shine.	I don't know
What emojis (if any) would you add to this tweet?	Definitely the best #WWEraw match in a long ass time. Glad Damien Priest is getting some shine.
I don't remember the last time a Sixers game gave me a heart attack but this game was a roller coaster. Hell of an effort but those 10 missed foul shots really hurt.	It is sarcastic
What emojis (if any) would you add to this tweet?	I don't remember the last time a Sixers game gave me a heart attack but this game was a roller coaster. 😞 😊 Hell of an effort but those 10 missed foul shots really hurt. 😊
Quarantine Day 256: Dear Ancient Greeks, re: the blanket-wearing I get it. #QuarantineLife	It is sarcastic

What emojis (if any) would you add to this tweet?	Quarantine Day 256: Dear Ancient Greeks, re: the blanket-wearing I get it. 😏 #QuarantineLife
my bf took my off his lock screen which obvi means hes cheating on me	I don't know
What emojis (if any) would you add to this tweet?	my bf took my off his lock screen which obvi means hes cheating on me
I'm big glad I'm not a Sonic fan because Sega gassed them mfers up for a lot of nothing.	It is sarcastic
What emojis (if any) would you add to this tweet?	I'm big glad I'm not a Sonic fan because Sega gassed them mfers up for a lot of nothing.
every time i see someone named david im like.. wow that really IS a guy named david	It is sarcastic
What emojis (if any) would you add to this tweet?	every time i see someone named david im like.. wow that really IS a guy named david 😏 😏
Gonna go cry now some no face told me to lose weight x	I don't know
What emojis (if any) would you add to this tweet?	Gonna go cry now some no face told me to lose weight x
Do you have any comments you would like to make?	

Participant Number	32
Question	Response
Qualification questions	
Consent to participate.	Yes
Are you over 18?	Yes
Do you use emojis?	Yes
Demographic Questions	
What is your gender?	Female
What age are you?	18-24
What is sarcasm?	saying something you don't mean for humour or to annoy someone
Emoji Usage Questions	
The villains in super hero films are awfully polite. They always confine their invasions to being above one particular city	It is sarcastic
What emojis (if any) would you add to this tweet?	The villains in super hero films are awfully polite. They always confine their invasions to being above one particular city 😏

I love not being pregnant so much its my fave thing about myself 🙈	It is not sarcastic
What emojis (if any) would you add to this tweet?	I love not being pregnant so much its my fave thing about myself 🙈
@ray_harren @tkinsonn buy really rare pokemon card	I don't know
What emojis (if any) would you add to this tweet?	@ray_harren @tkinsonn buy really rare pokemon card
Marshalls in Zandvoort be like #WTF1 @MattyWTF1 https://t.co/liviXOQjH7	It is not sarcastic
What emojis (if any) would you add to this tweet?	Marshalls in Zandvoort be like #WTF1 @MattyWTF1 https://t.co/liviXOQjH7 🤪
Wow did you see that ! Nice triple overtake from Norris !, #ImaginaryGrandPrix 🤪	It is sarcastic
What emojis (if any) would you add to this tweet?	Wow did you see that ! Nice triple overtake from Norris !, #ImaginaryGrandPrix 🤪
"you like ketchup but not tomatoes???" grow up"	It is sarcastic
What emojis (if any) would you add to this tweet?	"you like ketchup but not tomatoes???" 🤪
Big day in the Mumford house #sports day	It is not sarcastic
What emojis (if any) would you add to this tweet?	Big day in the Mumford house #sports day 😊
im usually pretty good at guessing the ending of a crime series but #clickbaitnetflix had me changing my guess every episode. SO good, highly recc	It is not sarcastic
What emojis (if any) would you add to this tweet?	im usually pretty good at guessing the ending of a crime series but #clickbaitnetflix had me changing my guess every episode. SO good, highly recc
wish i could ctrl + f my bedroom	It is sarcastic

What emojis (if any) would you add to this tweet?	wish i could ctrl + f my bedroom 🤔
@ShareZone5 @StockpickB You are a right bundle of laughs to take to the pictures Draft!	I don't know
What emojis (if any) would you add to this tweet?	@ShareZone5 @StockpickB You are a right bundle of laughs to take to the pictures Draft!
Do you have any comments you would like to make?	Nope

Participant Number	33
Question	Response
Qualification questions	
Consent to participate.	Yes
Are you over 18?	Yes
Do you use emojis?	Yes
Demographic Questions	
What is your gender?	Female
What age are you?	35-44
What is sarcasm?	Ironic statements? Something like that.
Emoji Usage Questions	
"If I could have changed anything about my childhood I would have never watched spongebob👉-no one"	It is not sarcastic
What emojis (if any) would you add to this tweet?	"If I could have changed anything about my childhood I would have never watched spongebob👉-no one"
# bbcqt It sure would be nice if Ms May decided to answer a question, rather than dance readily around it.	It is sarcastic
What emojis (if any) would you add to this tweet?	# bbcqt It sure would be nice if Ms May decided to answer a question, rather than dance readily around it. 😊
people in london are always asking me for directions !! i am as lost as you !!!!!	It is sarcastic

What emojis (if any) would you add to this tweet?	people in london are always asking me for directions !! i am as lost as you !!!!! 🤔
Vaccine dose 1. Thank you, science.	It is sarcastic
What emojis (if any) would you add to this tweet?	Vaccine dose 1. Thank you, science. 🤔
Does anyone not know Prince Harry got engaged? I dont think theres been enough in the news about it.	It is sarcastic
What emojis (if any) would you add to this tweet?	Does anyone not know Prince Harry got engaged? I dont think theres been enough in the news about it. 🤔
@sadgirlkali Make your husband agree to let you die first. FUN date topic for discussion	It is sarcastic
What emojis (if any) would you add to this tweet?	@sadgirlkali Make your husband agree to let you die first. FUN date topic for discussion 🤔
just tried to make a hot chocolate using only cold milk and wondered why it didn't taste right. that's where I'm at today.	It is not sarcastic
What emojis (if any) would you add to this tweet?	just tried to make a hot chocolate using only cold milk and wondered why it didn't taste right. that's where I'm at today. 🤔
Not me seriously debating buying a singular can of monsta energy of amazon because I'm really craving one but I'd feel guilty if I went into Tesco just to buy one	It is sarcastic
What emojis (if any) would you add to this tweet?	Not me seriously debating buying a singular can of monsta energy of amazon because I'm really craving one but I'd feel guilty if I went into Tesco just to buy one 🤔
im ollie im 5'8 and i think my 5'7 boyfriend is short	It is sarcastic
What emojis (if any) would you add to this tweet?	im ollie im 5'8 and i think my 5'7 boyfriend is short 🤔
"Tonight @ dinner I sat by & chatted w/ the former chancellor of Ole Miss, a former Miss MS, & the owner of the Miss America pageant Casual."	It is sarcastic

What emojis (if any) would you add to this tweet?	"Tonight @ dinner I sat by &; chatted w/ the former chancellor of Ole Miss, a former Miss MS, & the owner of the Miss America pageant Casual."
Do you have any comments you would like to make?	

Participant Number	34
Question	Response
Qualification questions	
Consent to participate.	Yes
Are you over 18?	Yes
Do you use emojis?	Yes
Demographic Questions	
What is your gender?	Male
What age are you?	35-44
What is sarcasm?	A verbal mechanism to cope with reality
Emoji Usage Questions	
wow this growth spurt is really taking longer than i thought haha	It is sarcastic
What emojis (if any) would you add to this tweet?	wow this growth spurt is really taking longer than i thought haha ☹️
Definitely the best #WWEraw match in a long ass time. Glad Damien Priest is getting some shine.	It is not sarcastic
What emojis (if any) would you add to this tweet?	Definitely the best #WWEraw match in a long ass time. Glad Damien Priest is getting some shine.
I don't remember the last time a Sixers game gave me a heart attack but this game was a roller coaster. Hell of an effort but those 10 missed foul shots really hurt.	I don't know
What emojis (if any) would you add to this tweet?	I don't remember the last time a Sixers game gave me a heart attack but this game was a roller coaster. Hell of an effort but those 10 missed foul shots really hurt. 😞
Quarantine Day 256: Dear Ancient Greeks, re: the blanket-wearing I get it. #QuarantineLife	It is sarcastic

What emojis (if any) would you add to this tweet?	Quarantine Day 256: Dear Ancient Greeks, re: the blanket-wearing I get it. #QuarantineLife 😊
my bf took my off his lock screen which obvi means hes cheating on me	It is sarcastic
What emojis (if any) would you add to this tweet?	my bf took my off his lock screen which obvi means hes cheating on me 😏
I'm big glad I'm not a Sonic fan because Sega gassed them mfers up for a lot of nothing.	It is not sarcastic
What emojis (if any) would you add to this tweet?	I'm big glad I'm not a Sonic fan because Sega gassed them mfers up for a lot of nothing. 😭
every time i see someone named david im like.. wow that really IS a guy named david	It is sarcastic
What emojis (if any) would you add to this tweet?	every time i see someone named david im like.. wow that really IS a guy named david
Gonna go cry now some no face told me to lose weight x	It is sarcastic
What emojis (if any) would you add to this tweet?	Gonna go cry now some no face told me to lose weight x 😏
Do you have any comments you would like to make?	

Participant Number	35
Question	Response
Qualification questions	
Consent to participate.	Yes
Are you over 18?	Yes
Do you use emojis?	Yes
Demographic Questions	
What is your gender?	Male
What age are you?	25-34
What is sarcasm?	Opposite or exaggerated for effect, to show skepticism.
Emoji Usage Questions	
The villains in super hero films are awfully polite. They always confine their invasions to being above one particular city	It is sarcastic
What emojis (if any) would you add to this tweet?	The villains in super hero films are awfully polite. They always confine their invasions to being above one particular city 👍

I love not being pregnant so much its my fave thing about myself	I don't know
What emojis (if any) would you add to this tweet?	I love not being pregnant so much its my fave thing about myself 😊
@ray_harren @tkinsonn buy really rare pokemon card	It is not sarcastic
What emojis (if any) would you add to this tweet?	@ray_harren @tkinsonn buy really rare pokemon card 😊
Marshalls in Zandvoort be like #WTF1 @MattyWTF1 https://t.co/liviXOQjH7	I don't know
What emojis (if any) would you add to this tweet?	Marshalls in Zandvoort be like 🤯 #WTF1 @MattyWTF1 https://t.co/liviXOQjH7
Wow did you see that! Nice triple overtake from Norris!, #ImaginaryGrandPrix	It is not sarcastic
What emojis (if any) would you add to this tweet?	Wow did you see that 🤯! Nice triple overtake from Norris 🙌!, #ImaginaryGrandPrix
"you like ketchup but not tomatoes??? grow up"	It is not sarcastic
What emojis (if any) would you add to this tweet?	"you like ketchup but not tomatoes??? grow up" 😡
Big day in the Mumford house #sports day	It is not sarcastic
What emojis (if any) would you add to this tweet?	Big day in the Mumford house 🎉 #sports day
im usually pretty good at guessing the ending of a crime series but #clickbaitnetflix had me changing my guess every episode. SO good, highly recc	It is not sarcastic
What emojis (if any) would you add to this tweet?	im usually pretty good at guessing the ending of a crime series but #clickbaitnetflix had me changing my guess every episode. SO good, highly recc 🙌
wish i could ctrl + f my bedroom	It is not sarcastic

What emojis (if any) would you add to this tweet?	wish i could ctrl + f my bedroom 😊
@ShareZone5 @StockpickB You are a right bundle of laughs to take to the pictures Draft!	It is sarcastic
What emojis (if any) would you add to this tweet?	@ShareZone5 @StockpickB You are a right bundle of laughs to take to the pictures Draft! 😞
Do you have any comments you would like to make?	

Participant Number	36
Question	Response
Qualification questions	
Consent to participate.	Yes
Are you over 18?	Yes
Do you use emojis?	Yes
Demographic Questions	
What is your gender?	Female
What age are you?	25-34
What is sarcasm?	Saying the opposite of what you mean, for humorous effect.
Emoji Usage Questions	
"If I could have changed anything about my childhood I would have never watched spongebob -no one"	It is not sarcastic
What emojis (if any) would you add to this tweet?	"If I could have changed anything about my childhood I would have never watched spongebob -no one" 😞
# bbcqt It sure would be nice if Ms May decided to answer a question, rather than dance readily around it.	It is not sarcastic
What emojis (if any) would you add to this tweet?	# bbcqt It sure would be nice if Ms May decided to answer a question, rather than dance readily around it. 😡

people in london are always asking me for directions !! i am as lost as you !!!!!	It is not sarcastic
What emojis (if any) would you add to this tweet?	people in london are always asking me for directions !! i am as lost as you !!!!! 😂
Vaccine dose 1. Thank you, science.	It is sarcastic
What emojis (if any) would you add to this tweet?	Vaccine dose 1. Thank you, science. 😏
Does anyone not know Prince Harry got engaged? I dont think theres been enough in the news about it.	It is sarcastic
What emojis (if any) would you add to this tweet?	Does anyone not know Prince Harry got engaged? I dont think theres been enough in the news about it. 😏
@sadgirlkali Make your husband agree to let you die first. FUN date topic for discussion	It is not sarcastic
What emojis (if any) would you add to this tweet?	@sadgirlkali Make your husband agree to let you die first. FUN date topic for discussion 😏
just tried to make a hot chocolate using only cold milk and wondered why it didn't taste right. that's where I'm at today.	It is not sarcastic
What emojis (if any) would you add to this tweet?	just tried to make a hot chocolate using only cold milk and wondered why it didn't taste right. that's where I'm at today. 🙄
Not me seriously debating buying a singular can of monsta energy of amazon because I'm really craving one but I'd feel guilty if I went into Tesco just to buy one	It is not sarcastic
What emojis (if any) would you add to this tweet?	Not me seriously debating buying a singular can of monsta energy of amazon because I'm really craving one but I'd feel guilty if I went into Tesco just to buy one 😂
im ollie im 5'8 and i think my 5'7 boyfriend is short	It is sarcastic
What emojis (if any) would you add to this tweet?	im ollie im 5'8 and i think my 5'7 boyfriend is short 😏

"Tonight @ dinner I sat by & chatted w/ the former chancellor of Ole Miss, a former Miss MS, & the owner of the Miss America pageant Casual."	It is not sarcastic
What emojis (if any) would you add to this tweet?	"Tonight @ dinner I sat by & chatted w/ the former chancellor of Ole Miss, a former Miss MS, & the owner of the Miss America pageant Casual." 😊
Do you have any comments you would like to make?	

Participant Number	37
Question	Response
Qualification questions	
Consent to participate.	Yes
Are you over 18?	Yes
Do you use emojis?	Yes
Demographic Questions	
What is your gender?	Female
What age are you?	25-34
What is sarcasm?	saying the opposite of what you actually mean while trying to be either rude or funny (or both)
Emoji Usage Questions	
wow this growth spurt is really taking longer than i thought haha 😏	It is not sarcastic
What emojis (if any) would you add to this tweet?	wow this growth spurt is really taking longer than i thought haha 😏
Definitely the best #WWEraw match in a long ass time. Glad Damien Priest is getting some shine.	It is not sarcastic
What emojis (if any) would you add to this tweet?	Definitely the best #WWEraw match in a long ass time. Glad Damien Priest is getting some shine. 👍
I don't remember the last time a Sixers game gave me a heart attack but this game was a roller coaster. Hell of an effort but those 10 missed foul shots really hurt.	It is not sarcastic

What emojis (if any) would you add to this tweet?	I don't remember the last time a Sixers game gave me a heart attack but this game was a roller coaster. Hell of an effort but those 10 missed foul shots really hurt. 😞
Quarantine Day 256: Dear Ancient Greeks, re: the blanket-wearing I get it. #QuarantineLife	It is not sarcastic
What emojis (if any) would you add to this tweet?	Quarantine Day 256: Dear Ancient Greeks, re: the blanket-wearing I get it. #QuarantineLife 😊
my bf took my off his lock screen which obvi means hes cheating on me	It is not sarcastic
What emojis (if any) would you add to this tweet?	my bf took my off his lock screen which obvi means hes cheating on me 😭
I'm big glad I'm not a Sonic fan because Sega gassed them mfers up for a lot of nothing.	It is not sarcastic
What emojis (if any) would you add to this tweet?	I'm big glad I'm not a Sonic fan because Sega gassed them mfers up for a lot of nothing. 😊
every time i see someone named david im like.. wow that really IS a guy named david	It is not sarcastic
What emojis (if any) would you add to this tweet?	every time i see someone named david im like.. wow that really IS a guy named david 😭
Gonna go cry now some no face told me to lose weight x	It is sarcastic
What emojis (if any) would you add to this tweet?	Gonna go cry now some no face told me to lose weight x 😞
Do you have any comments you would like to make?	

Participant Number	38
Question	Response
Qualification questions	
Consent to participate.	Yes
Are you over 18?	Yes
Do you use emojis?	Yes
Demographic Questions	
What is your gender?	Female
What age are you?	18-24
What is sarcasm?	saying something you don't agree with in order to mock the sort of person who would say that

Emoji Usage Questions	
The villains in super hero films are awfully polite. They always confine their invasions to being above one particular city	It is sarcastic
What emojis (if any) would you add to this tweet?	The villains in super hero films are awfully polite. They always confine their invasions to being above one particular city 😏
I love not being pregnant so much its my fave thing about myself	It is sarcastic
What emojis (if any) would you add to this tweet?	I love not being pregnant so much its my fave thing about myself 😏
@ray_harren @tkinsonn buy really rare pokemon card	It is not sarcastic
What emojis (if any) would you add to this tweet?	@ray_harren @tkinsonn buy really rare pokemon card 😏
Marshalls in Zandvoort be like #WTF1 @MattyWTF1 https://t.co/liviXOQjH7 :eyes:	It is not sarcastic
What emojis (if any) would you add to this tweet?	Marshalls in Zandvoort be like #WTF1 @MattyWTF1 https://t.co/liviXOQjH7 :eyes:
Wow did you see that ! Nice triple overtake from Norris !, #ImaginaryGrandPrix	It is sarcastic
What emojis (if any) would you add to this tweet?	Wow did you see that ! Nice triple overtake from Norris !, #ImaginaryGrandPrix 😏
"you like ketchup but not tomatoes???" grow up"	It is not sarcastic
What emojis (if any) would you add to this tweet?	"you like ketchup but not tomatoes???" grow up"
Big day in the Mumford house #sports day	It is not sarcastic
What emojis (if any) would you add to this tweet?	Big day in the Mumford house #sports day
im usually pretty good at guessing the ending of a crime series but #clickbaitnetflix had me changing my guess every episode. SO good, highly recc	It is sarcastic

What emojis (if any) would you add to this tweet?	im usually pretty good at guessing the ending of a crime series but #clickbaitnetflix had me changing my guess every episode. SO good, highly recc 👍
wish i could ctrl + f my bedroom	It is not sarcastic
What emojis (if any) would you add to this tweet?	wish i could ctrl + f my bedroom 😞
@ShareZone5 @StockpickB You are a right bundle of laughs to take to the pictures Draft!	It is not sarcastic
What emojis (if any) would you add to this tweet?	😂@ShareZone5 @StockpickB You are a right bundle of laughs to take to the pictures Draft!
Do you have any comments you would like to make?	

Participant Number	39
Question	Response
Qualification questions	
Consent to participate.	Yes
Are you over 18?	Yes
Do you use emojis?	Yes
Demographic Questions	
What is your gender?	Male
What age are you?	18-24
What is sarcasm?	Saying something but meaning opposite, often to be funny or mocking someone
Emoji Usage Questions	
"If I could have changed anything about my childhood I would have never watched spongebob👉 -no one"	It is not sarcastic
What emojis (if any) would you add to this tweet?	"If I could have changed anything about my childhood I would have never watched spongebob👉 -no one" 😞
#bbcqt It sure would be nice if Ms May decided to answer a question, rather than dance readily around it.	It is sarcastic

What emojis (if any) would you add to this tweet?	# bbcqt It sure would be nice if Ms May decided to answer a question, rather than dance readily around it. 😞😞
people in london are always asking me for directions !! i am as lost as you !!!!!	It is not sarcastic
What emojis (if any) would you add to this tweet?	people in london are always asking me for directions !! i am as lost as you !!!!! 😞
Vaccine dose 1. Thank you, science.	It is not sarcastic
What emojis (if any) would you add to this tweet?	Vaccine dose 1. Thank you, science. 👍
Does anyone not know Prince Harry got engaged? I dont think theres been enough in the news about it.	It is not sarcastic
What emojis (if any) would you add to this tweet?	Does anyone not know Prince Harry got engaged? I dont think theres been enough in the news about it. 😞
@sadgirlkali Make your husband agree to let you die first. FUN date topic for discussion	It is not sarcastic
What emojis (if any) would you add to this tweet?	@sadgirlkali Make your husband agree to let you die first. FUN date topic for discussion 😞
just tried to make a hot chocolate using only cold milk and wondered why it didn't taste right. that's where I'm at today.	It is not sarcastic
What emojis (if any) would you add to this tweet?	just tried to make a hot chocolate using only cold milk and wondered why it didn't taste right. that's where I'm at today. 😞
Not me seriously debating buying a singular can of monsta energy of amazon because I'm really craving one but I'd feel guilty if I went into Tesco just to buy one	It is not sarcastic
What emojis (if any) would you add to this tweet?	Not me seriously debating buying a singular can of monsta energy of amazon because I'm really craving one but I'd feel guilty if I went into Tesco just to buy one
im ollie im 5'8 and i think my 5'7 boyfriend is short	It is not sarcastic
What emojis (if any) would you add to this tweet?	im ollie im 5'8 and i think my 5'7 boyfriend is short 😞

"Tonight @ dinner I sat by &; chatted w/ the former chancellor of Ole Miss, a former Miss MS, & the owner of the Miss America pageant Casual."	It is not sarcastic
What emojis (if any) would you add to this tweet?	"Tonight @ dinner I sat by &; chatted w/ the former chancellor of Ole Miss, a former Miss MS, & the owner of the Miss America pageant Casual." 😊
Do you have any comments you would like to make?	

Participant Number	40
Question	Response
Qualification questions	
Consent to participate.	Yes
Are you over 18?	Yes
Do you use emojis?	Yes
Demographic Questions	
What is your gender?	Female
What age are you?	35-44
What is sarcasm?	deprecating humour
Emoji Usage Questions	
wow this growth spurt is really taking longer than i thought haha	It is sarcastic
What emojis (if any) would you add to this tweet?	wow this growth spurt is really taking longer than i thought haha 😊
Definitely the best #WWEraw match in a long ass time. Glad Damien Priest is getting some shine.	It is not sarcastic
What emojis (if any) would you add to this tweet?	😊 Definitely the best #WWEraw match in a long ass time. Glad Damien Priest is getting some shine.
I don't remember the last time a Sixers game gave me a heart attack but this game was a roller coaster. Hell of an effort but those 10 missed foul shots really hurt. 😞	It is not sarcastic

What emojis (if any) would you add to this tweet?	I don't remember the last time a Sixers game gave me a heart attack but this game was a roller coaster. Hell of an effort but those 10 missed foul shots really hurt. 😞
Quarantine Day 256: Dear Ancient Greeks, re: the blanket-wearing I get it. #QuarantineLife	It is not sarcastic
What emojis (if any) would you add to this tweet?	Quarantine Day 256: Dear Ancient Greeks, re: the blanket-wearing I get it. #QuarantineLife
my bf took my off his lock screen which obvi means hes cheating on me	It is sarcastic
What emojis (if any) would you add to this tweet?	my bf took my off his lock screen which obvi means hes cheating on me 😊
I'm big glad I'm not a Sonic fan because Sega gassed them mfers up for a lot of nothing.	It is not sarcastic
What emojis (if any) would you add to this tweet?	I'm big glad I'm not a Sonic fan because Sega gassed them mfers up for a lot of nothing.
every time i see someone named david im like.. wow that really IS a guy named david	It is not sarcastic
What emojis (if any) would you add to this tweet?	every time i see someone named david im like.. wow that really IS a guy named david
Gonna go cry now some no face told me to lose weight x	It is sarcastic
What emojis (if any) would you add to this tweet?	Gonna go cry now some no face told me to lose weight x 😞 😊
Do you have any comments you would like to make?	

Participant Number	41
Question	Response
Qualification questions	
Consent to participate.	Yes
Are you over 18?	Yes
Do you use emojis?	Yes
Demographic Questions	
What is your gender?	Female
What age are you?	25-34
What is sarcasm?	Eh What do you think?
Emoji Usage Questions	

The villains in super hero films are awfully polite. They always confine their invasions to being above one particular city	It is sarcastic
What emojis (if any) would you add to this tweet?	The villains in super hero films are awfully polite. They always confine their invasions to being above one particular city 😞
I love not being pregnant so much its my fave thing about myself	It is not sarcastic
What emojis (if any) would you add to this tweet?	I love not being pregnant so much its my fave thing about myself 😞
@ray_harren @tkinsonn buy really rare pokemon card	It is not sarcastic
What emojis (if any) would you add to this tweet?	@ray_harren @tkinsonn buy really rare pokemon card
Marshalls in Zandvoort be like #WTF1 @MattyWTF1 https://t.co/liviXOQjH7	It is not sarcastic
What emojis (if any) would you add to this tweet?	Marshalls in Zandvoort be like #WTF1 😞 @MattyWTF1 https://t.co/liviXOQjH7
Wow did you see that ! Nice triple overtake from Norris !, #ImaginaryGrandPrix	I don't know
What emojis (if any) would you add to this tweet?	Wow did you see that ! Nice triple overtake from Norris !, #ImaginaryGrandPrix
"you like ketchup but not tomatoes???" grow up"	It is not sarcastic
What emojis (if any) would you add to this tweet?	"you like ketchup but not tomatoes???" grow up" 😞
Big day in the Mumford house #sports day	It is not sarcastic
What emojis (if any) would you add to this tweet?	Big day in the Mumford house #sports day
im usually pretty good at guessing the ending of a crime series but #clickbaitnetflix had me changing my guess every episode. SO good, highly recc	It is not sarcastic

What emojis (if any) would you add to this tweet?	im usually pretty good at guessing the ending of a crime series but #clickbaitnetflix had me changing my guess every episode. SO good, highly recc 😁
wish i could ctrl + f my bedroom	It is sarcastic
What emojis (if any) would you add to this tweet?	wish i could ctrl + f my bedroom 😞
@ShareZone5 @StockpickB You are a right bundle of laughs to take to the pictures Draft!	I don't know
What emojis (if any) would you add to this tweet?	@ShareZone5 @StockpickB You are a right bundle of laughs to take to the pictures Draft!
Do you have any comments you would like to make?	

Participant Number	42
Question	Response
Qualification questions	
Consent to participate.	Yes
Are you over 18?	Yes
Do you use emojis?	Yes
Demographic Questions	
What is your gender?	Male
What age are you?	18-24
What is sarcasm?	To say something that means the opposite of what is implied or intended
Emoji Usage Questions	
"If I could have changed anything about my childhood I would have never watched spongebob👉 -no one"	It is not sarcastic
What emojis (if any) would you add to this tweet?	"If I could have changed anything about my childhood I would have never watched spongebob👉 -no one" 😁
#bbcqt It sure would be nice if Ms May decided to answer a question, rather than dance readily around it.	It is sarcastic

What emojis (if any) would you add to this tweet?	# bbcqt It sure would be nice if Ms May decided to answer a question, rather than dance readily around it. 😞
people in london are always asking me for directions !! i am as lost as you !!!!!	It is not sarcastic
What emojis (if any) would you add to this tweet?	people in london are always asking me for directions !! i am as lost as you !!!!! 😊
Vaccine dose 1. Thank you, science.	It is not sarcastic
What emojis (if any) would you add to this tweet?	Vaccine dose 1. Thank you, science. ❤️
Does anyone not know Prince Harry got engaged? I dont think theres been enough in the news about it.	It is sarcastic
What emojis (if any) would you add to this tweet?	Does anyone not know Prince Harry got engaged? I dont think theres been enough in the news about it.
@sadgirlkali Make your husband agree to let you die first. FUN date topic for discussion	It is sarcastic
What emojis (if any) would you add to this tweet?	@sadgirlkali Make your husband agree to let you die first. FUN date topic for discussion 😞
just tried to make a hot chocolate using only cold milk and wondered why it didn't taste right. that's where I'm at today.	It is not sarcastic
What emojis (if any) would you add to this tweet?	just tried to make a hot chocolate using only cold milk and wondered why it didn't taste right. that's where I'm at today. 🤔
Not me seriously debating buying a singular can of monsta energy of amazon because I'm really craving one but I'd feel guilty if I went into Tesco just to buy one	It is not sarcastic
What emojis (if any) would you add to this tweet?	Not me seriously debating buying a singular can of monsta energy of amazon because I'm really craving one but I'd feel guilty if I went into Tesco just to buy one 😞
im ollie im 5'8 and i think my 5'7 boyfriend is short	I don't know
What emojis (if any) would you add to this tweet?	im ollie im 5'8 and i think my 5'7 boyfriend is short

"Tonight @ dinner I sat by &; chatted w/ the former chancellor of Ole Miss, a former Miss MS, & the owner of the Miss America pageant Casual."	It is not sarcastic
What emojis (if any) would you add to this tweet?	"Tonight @ dinner I sat by &; chatted w/ the former chancellor of Ole Miss, a former Miss MS, & the owner of the Miss America pageant Casual." 🙄
Do you have any comments you would like to make?	difficult to just guess sarcastic emojis, but fun exercise

Participant Number	43
Question	Response
Qualification questions	
Consent to participate.	Yes
Are you over 18?	Yes
Do you use emojis?	Yes
Demographic Questions	
What is your gender?	Male
What age are you?	45-64
What is sarcasm?	the form of irony that used to mock
Emoji Usage Questions	
wow this growth spurt is really taking longer than i thought haha	It is sarcastic
What emojis (if any) would you add to this tweet?	wow this growth spurt is really taking longer than i thought haha 🙄
Definitely the best #WWEraw match in a long ass time. Glad Damien Priest is getting some shine.	It is not sarcastic
What emojis (if any) would you add to this tweet?	Definitely the best #WWEraw match in a long ass time. Glad Damien Priest is getting some shine. 🙄
I don't remember the last time a Sixers game gave me a heart attack but this game was a roller coaster. Hell of an effort but those 10 missed foul shots really hurt.	It is not sarcastic

What emojis (if any) would you add to this tweet?	I don't remember the last time a Sixers game gave me a heart attack but this game was a roller coaster. Hell of an effort but those 10 missed foul shots really hurt. 🤔
Quarantine Day 256: Dear Ancient Greeks, re: the blanket-wearing I get it. #QuarantineLife	It is sarcastic
What emojis (if any) would you add to this tweet?	Quarantine Day 256: Dear Ancient Greeks, re: the blanket-wearing I get it. #QuarantineLife 😊
my bf took my off his lock screen which obvi means hes cheating on me	It is sarcastic
What emojis (if any) would you add to this tweet?	my bf took my off his lock screen which obvi means hes cheating on me 😊
I'm big glad I'm not a Sonic fan because Sega gassed them mfers up for a lot of nothing.	It is not sarcastic
What emojis (if any) would you add to this tweet?	I'm big glad I'm not a Sonic fan because Sega gassed them mfers up for a lot of nothing. 🤔
every time i see someone named david im like.. wow that really IS a guy named david	I don't know
What emojis (if any) would you add to this tweet?	every time i see someone named david im like.. wow that really IS a guy named david
Gonna go cry now some no face told me to lose weight x 😊	It is sarcastic
What emojis (if any) would you add to this tweet?	Gonna go cry now some no face told me to lose weight x 😊
im ollie im 5'8 and i think my 5'7 boyfriend is short	I don't know
Do you have any comments you would like to make?	A lot of these are quite hard to judge without context

Participant Number	44
Question	Response
Qualification questions	
Consent to participate.	Yes
Are you over 18?	Yes
Do you use emojis?	Yes
Demographic Questions	
What is your gender?	Male
What age are you?	18-24

What is sarcasm?	Being ironic when speaking to people
Emoji Usage Questions	
Loving season 4 of trump does America. Funniest season yet #DonaldTrump #Trump #MAGA #MAGA2020	It is sarcastic
What emojis (if any) would you add to this tweet?	Loving season 4 of trump does America. Funniest season yet #DonaldTrump #Trump #MAGA #MAGA2020 🤩🤩
Thank god I just accidentally snapped a rando guy from high school yas queen with acne cream all over my face	It is sarcastic
What emojis (if any) would you add to this tweet?	Thank god I just accidentally snapped a rando guy from high school yas queen with acne cream all over my face 🤡🐵
I hurt my foot like 3 days ago, I have no idea how, but it hurts to put pressure on it. Love that for me	It is sarcastic
What emojis (if any) would you add to this tweet?	I hurt my foot like 3 days ago, I have no idea how, but it hurts to put pressure on it. Love that for me 🤡👍
i have this reoccurring nightmare where i accidentally forget to put on shoes before school and i have to spend the whole day barefoot	It is not sarcastic
What emojis (if any) would you add to this tweet?	i have this reoccurring nightmare where i accidentally forget to put on shoes before school and i have to spend the whole day barefoot
@AlexShawESPN @robwishart @GNev2 Does he order 11 at once and drink each one at just over 5 minutes, OR do we have to take into account going to the bar? Either way its a disgrace and not what we should be promoting to the kids.	It is not sarcastic
What emojis (if any) would you add to this tweet?	@AlexShawESPN @robwishart @GNev2 Does he order 11 at once and drink each one at just over 5 minutes, OR do we have to take into account going to the bar? Either way its a disgrace and not what we should be promoting to the kids.
"me: trying to sleep slightly earlier than usual bc I feel like shit my friend, texting the group chat 13 separate times at nearly 4am: hello I dont think so! how abt I tell u abt how bad things are going instead :)"	It is sarcastic

What emojis (if any) would you add to this tweet?	"me: trying to sleep slightly earlier than usual bc I feel like shit my friend, texting the group chat 13 separate times at nearly 4am: hello I donâ€™t think so! how abt I tell u abt how bad things are going instead :)" 🤪😭😭
5:30 banshee-like kitten zoomies are definitely my all-time favorite alarm clock, and the sound of jewelry boxes flipping over and burnouts on the wood floor make for the calmest, most enjoyable start to any workday. 😭😭	It is sarcastic
What emojis (if any) would you add to this tweet?	5:30 banshee-like kitten zoomies are definitely my all-time favorite alarm clock, and the sound of jewelry boxes flipping over and burnouts on the wood floor make for the calmest, most enjoyable start to any workday. 😭😭
Not having this Arsenal kit, looks like Ajax. And the goalies wearing the away kit.	It is not sarcastic
What emojis (if any) would you add to this tweet?	Not having this Arsenal kit, looks like Ajax. And the goalies wearing the away kit.
me and my gf are on a reality tv show binge lately does anyone have any suggestions for particularly Unhinged reality shows	It is not sarcastic
What emojis (if any) would you add to this tweet?	me and my gf are on a reality tv show binge lately does anyone have any suggestions for particularly Unhinged reality shows
Sometimes I feel like all this effort is just like sticking diamond encrusted alloys on a knackered Corsa. I mean, shit is what it is at the end of the day.	It is sarcastic
What emojis (if any) would you add to this tweet?	Sometimes I feel like all this effort is just like sticking diamond encrusted alloys on a knackered Corsa. I mean, shit is what it is at the end of the day. 🤩
Do you have any comments you would like to make?	

Participant Number	45
Question	Response
Qualification questions	
Consent to participate.	Yes
Are you over 18?	Yes
Do you use emojis?	Yes

Demographic Questions	
What is your gender?	Male
What age are you?	35-44
What is sarcasm?	Ironic expression of some information, usually by saying something where the literal meaning of the message is not the actual message the sender wants to express.
Emoji Usage Questions	
Loving season 4 of trump does America. Funniest season yet #DonaldTrump #Trump #MAGA #MAGA2020	It is not sarcastic
What emojis (if any) would you add to this tweet?	Loving season 4 of trump does America. 😄 Funniest season yet 😄 #DonaldTrump #Trump #MAGA #MAGA2020
a single man directed by tom ford simultaneously resurrected me from death only to brutally murder me once more.	It is sarcastic
What emojis (if any) would you add to this tweet?	a single man directed by tom ford simultaneously resurrected me from death only to brutally murder me once more. 😱
Hey Siri, how do I stop simping?	It is not sarcastic
What emojis (if any) would you add to this tweet?	Hey Siri, how do I stop simping? 🙄
aw i had a dream i bought a big book of words and their meanings and now im awake and sad (also in the dream i was wondering around the most magical library/bookstore/gift shop???)	It is not sarcastic
What emojis (if any) would you add to this tweet?	aw i had a dream i bought a big book of words and their meanings and now im awake and sad 😞 (also in the dream i was wondering around the most magical library/bookstore/gift shop???)
I want to join @IdenaNetwork to become a validator of the first Proof-Of-Person Blockchain #idenainvite	It is sarcastic
What emojis (if any) would you add to this tweet?	I want to join @IdenaNetwork to become a validator of the first Proof-Of-Person Blockchain #idenainvite

Hey does anyone know of any organizations that have massive stockpiles of money that could be super useful to the world during a public crisis?????	It is sarcastic
What emojis (if any) would you add to this tweet?	Hey does anyone know of any organizations that have massive stockpiles of money that could be super useful to the world during a public crisis????? 😞
Wow Bdubs can bench press 150 kilometers	It is sarcastic
What emojis (if any) would you add to this tweet?	Wow Bdubs can bench press 150 kilometers 🤔😂
"Join me on @WeAre8Official to help save our planet in just 2 minutes a day. UN #UnitedForGood @WeAre8Official https://t.co/s2LdOOJleR "	I don't know
What emojis (if any) would you add to this tweet?	"Join me on @WeAre8Official to help save our planet in just 2 minutes a day. UN 🙏 #UnitedForGood @WeAre8Official https://t.co/s2LdOOJleR "
@stereogum @ChemBros I swear I heard this sample way back as far as London 2012 opening ceremony??	It is not sarcastic
What emojis (if any) would you add to this tweet?	@stereogum @ChemBros I swear I heard this sample way back as far as London 2012 opening ceremony?? 😞😞
Nothing screams Im a glamorous cosmopolitan woman like following your dog down the street in the midst of winter, saying go potty! Go POTTY! over and over again.	It is sarcastic
What emojis (if any) would you add to this tweet?	Nothing screams Im a glamorous cosmopolitan woman 🤔 like following your dog 🐕 down the street in the midst of winter, saying go potty! Go POTTY! 🤔 over and over again. 😂
Do you have any comments you would like to make?	

Participant Number	46
Question	Response
Qualification questions	
Consent to participate.	Yes
Are you over 18?	Yes
Do you use emojis?	Yes

Demographic Questions	
What is your gender?	Male
What age are you?	45-64
What is sarcasm?	sarcasm is just the most mind-blowing, clear and sophisticated form of communication in the world
Emoji Usage Questions	
Loving season 4 of trump does America. Funniest season yet #DonaldTrump #Trump #MAGA #MAGA2020	It is sarcastic
What emojis (if any) would you add to this tweet?	Loving season 4 of trump does America. Funniest season yet #DonaldTrump #Trump #MAGA #MAGA2020 😊
Thank god I just accidentally snapped a rando guy from high school yas queen with acne cream all over my face	It is sarcastic
What emojis (if any) would you add to this tweet?	Thank god I just accidentally snapped a rando guy from high school yas queen with acne cream all over my face 🤔
I hurt my foot like 3 days ago, I have no idea how, but it hurts to put pressure on it. Love that for me	It is not sarcastic
What emojis (if any) would you add to this tweet?	I hurt my foot like 3 days ago, I have no idea how, but it hurts to put pressure on it. Love that for me 😞
i have this reoccurring nightmare where i accidentally forget to put on shoes before school and i have to spend the whole day barefoot	It is not sarcastic
What emojis (if any) would you add to this tweet?	i have this reoccurring nightmare where i accidentally forget to put on shoes before school 😞 and i have to spend the whole day barefoot
@AlexShawESPN @robwishart @GNev2 Does he order 11 at once and drink each one at just over 5 minutes, OR do we have to take into account going to the bar? Either way its a disgrace and not what we should be promoting to the kids.	It is not sarcastic
What emojis (if any) would you add to this tweet?	@AlexShawESPN @robwishart @GNev2 Does he order 11 at once and drink each one at just over 5 minutes, OR do we have to take into account going to the bar? Either way its a

	disgrace and not what we should be promoting to the kids. 😡
"me: trying to sleep slightly earlier than usual bc I feel like shit my friend, texting the group chat 13 separate times at nearly 4am: hello I donâ€™t think so! how abt I tell u abt how bad things are going instead :)"	It is sarcastic
What emojis (if any) would you add to this tweet?	"me: trying to sleep slightly earlier than usual bc I feel like shit my friend, texting the group chat 13 separate times at nearly 4am: hello I donâ€™t think so! how abt I tell u abt how bad things are going instead :)"
5:30 banshee-like kitten zoomies are definitely my all-time favorite alarm clock, and the sound of jewelry boxes flipping over and burnouts on the wood floor make for the calmest, most enjoyable start to any workday.	It is sarcastic
What emojis (if any) would you add to this tweet?	5:30 banshee-like kitten zoomies are definitely my all-time favorite alarm clock, and the sound of jewelry boxes flipping over and burnouts on the wood floor make for the calmest, most enjoyable start to any workday. 😊
Not having this Arsenal kit, looks like Ajax. And the goalies wearing the away kit.	It is not sarcastic
What emojis (if any) would you add to this tweet?	Not having this Arsenal kit, looks like Ajax. And the goalies wearing the away kit. 🙈
me and my gf are on a reality tv show binge lately does anyone have any suggestions for particularly Unhinged reality shows	It is not sarcastic
What emojis (if any) would you add to this tweet?	me and my gf are on a reality tv show binge lately does anyone have any suggestions for particularly Unhinged reality shows
Sometimes I feel like all this effort is just like sticking diamond encrusted alloys on a knackered Corsa. I mean, shit is what it is at the end of the day.	It is not sarcastic
What emojis (if any) would you add to this tweet?	Sometimes I feel like all this effort is just like sticking diamond encrusted alloys on a knackered Corsa. I mean, shit is what it is at the end of the day. 😞
Do you have any comments you would like to make?	

Participant Number	47
Question	Response
Qualification questions	
Consent to participate.	Yes
Are you over 18?	Yes
Do you use emojis?	Yes
Demographic Questions	
What is your gender?	Male
What age are you?	25-34
What is sarcasm?	Being funny in a dry way, not really meaning what is said
Emoji Usage Questions	
Loving season 4 of trump does America. Funniest season yet #DonaldTrump #Trump #MAGA #MAGA2020	I don't know
What emojis (if any) would you add to this tweet?	Loving season 4 of trump does America. Funniest season yet 🤔 #DonaldTrump #Trump #MAGA #MAGA2020
"Drop in Center to let people get the 1st or 2nd Vaccine open today . I went thinking I was able to get my 2nd one . Wait in the que 30 mins .sits down arm ready to get ! Sorry your 12hrs to early !!! We cannot vacinate you till 56 days !!! @NicolaSturgeon #Seriously"	It is not sarcastic
What emojis (if any) would you add to this tweet?	"Drop in Center to let people get the 1st or 2nd Vaccine open today . I went thinking I was able to get my 2nd one . Wait in the que 30 mins .sits down arm ready to get ! Sorry your 12hrs to early !!! We cannot vacinate you till 56 days !!! 😡 @NicolaSturgeon #Seriously"
I hurt my foot like 3 days ago, I have no idea how, but it hurts to put pressure on it. Love that for me	It is not sarcastic
What emojis (if any) would you add to this tweet?	I hurt my foot like 3 days ago, I have no idea how, but it hurts to put pressure on it. Love that for me 😞
Do you have any comments you would like to make?	

Participant Number	48
Question	Response

Qualification questions	
Consent to participate.	Yes
Are you over 18?	Yes
Do you use emojis?	Yes
Demographic Questions	
What is your gender?	Female
What age are you?	25-34
What is sarcasm?	To convey a message by expressing the opposite feeling in a manner that makes it obvious for the recipient of the message
Emoji Usage Questions	
Loving season 4 of trump does America. Funniest season yet #DonaldTrump #Trump #MAGA #MAGA2020	I don't know
What emojis (if any) would you add to this tweet?	Loving season 4 of trump does America. Funniest season yet #DonaldTrump #Trump #MAGA #MAGA2020
@benshapiro its true, every time my little cousins put on their masks they choke to death and have to be revived. its very stressful for us.	It is sarcastic
What emojis (if any) would you add to this tweet?	@benshapiro its true, every time my little cousins put on their masks they choke to death and have to be revived. its very stressful for us. 😞
Pissed off at @TMobile_USA and just want out of my contract, but I'm sure that would just be way too easy, ugh :(It is sarcastic
What emojis (if any) would you add to this tweet?	Pissed off at @TMobile_USA and just want out of my contract, but I'm sure that would just be way too easy, ugh :(
Finally listening to Lukes album and I really like it.. very vibey	It is not sarcastic
What emojis (if any) would you add to this tweet?	Finally listening to Lukes album and I really like it.. very vibey
Why do people get so opinionated over other people going to uni? Like its my debt and my time Im wasting leave me alone	It is not sarcastic
What emojis (if any) would you add to this tweet?	Why do people get so opinionated over other people going to uni? Like its my debt and my time Im wasting leave me alone

Football is turning into an anatomy lesson. COOL	It is sarcastic
What emojis (if any) would you add to this tweet?	Football is turning into an anatomy lesson. 😏 COOL
@BIGRXD12 ah yes, people with eating disorders, famous for easily being able to not worry about their weight	It is sarcastic
What emojis (if any) would you add to this tweet?	@BIGRXD12 ah yes, people with eating disorders, famous for easily being able to not worry about their weight
the forbidden grooves, genius of love, and maroon 5 were exactly the vibes i needed today thank u so much for sharing ur talent with us on ur live stream @sidneyg156	It is not sarcastic
What emojis (if any) would you add to this tweet?	the forbidden grooves, genius of love, and maroon 5 were exactly the vibes i needed today thank u so much for sharing ur talent with us on ur live stream @sidneyg156 🎵
i needa win cmon wildcat william #JWUFAMBINGO	I don't know
What emojis (if any) would you add to this tweet?	i needa win cmon wildcat william #JWUFAMBINGO
"As if I didn't know this anyway! I'm an Owl according to the #BBCBodyClock quiz what are you? https://t.co/vM07K82CTg "	I don't know
What emojis (if any) would you add to this tweet?	"As if I didn't know this anyway! I'm an Owl according to the #BBCBodyClock quiz what are you? https://t.co/vM07K82CTg "
Do you have any comments you would like to make?	

Participant Number	49
Question	Response
Qualification questions	
Consent to participate.	Yes
Are you over 18?	Yes
Do you use emojis?	Yes
Demographic Questions	
What is your gender?	Female
What age are you?	18-24

What is sarcasm?	saying something mockingly
Emoji Usage Questions	
Loving season 4 of trump does America. Funniest season yet ususus#DonaldTrump #Trump #MAGA #MAGA2020	It is not sarcastic
What emojis (if any) would you add to this tweet?	Loving season 4 of trump does America. Funniest season yet 🤔🙏 ususus#DonaldTrump #Trump #MAGA #MAGA2020
i would kill a man for a forehead kiss rn	It is not sarcastic
What emojis (if any) would you add to this tweet?	i would kill a man for a forehead kiss rn
Love being called the devil for taking away someones phone at summer school	It is sarcastic
What emojis (if any) would you add to this tweet?	Love being called the devil for taking away someones phone at summer school 😬😬😬
"Hello @Ocado, I just had my food shopping delivered by a man called Gary and honestly he was one of the nicest drivers I have ever had. He was attentive, talkative and was interested in how our days had been. Please can you let his managers know. Asset to the company."	It is not sarcastic
What emojis (if any) would you add to this tweet?	"Hello @Ocado, I just had my food shopping delivered by a man called Gary and honestly he was one of the nicest drivers I have ever had. He was attentive, talkative and was interested in how our days had been. Please can you let his managers know. Asset to the company. ★★★★★"
"Few of us who are in ""low classed jobs"" who are still in work as we are classed as essential workers are the same people who were claiming UC over the past few years & got scrutinised for it. #UniversalCredit is trending because now people see how UC isn't just for ""lower class""."	It is not sarcastic
What emojis (if any) would you add to this tweet?	"Few of us who are in ""low classed jobs"" who are still in work as we are classed as essential workers are the same people who were claiming UC over the past few years & got

	scrutinised for it. #UniversalCredit is trending because now people see how UC isn't just for ""lower class""."
everyone pls stop shooting fireworks my dog is scared :(It is not sarcastic
What emojis (if any) would you add to this tweet?	everyone pls stop shooting fireworks my dog is scared :(
I love days when Rob works short call and is only at the hospital for checks watch 13 hours	It is sarcastic
What emojis (if any) would you add to this tweet?	I love days when Rob works short call and is only at the hospital for checks watch 13 hours 😭
The key thing to remember here is these boys are someone's loved one. They did their best. Lets leave the hate. Racism isn't the answer either. #eurofinal #Euro2021	It is not sarcastic
What emojis (if any) would you add to this tweet?	The key thing to remember here is these boys are someone's loved one. They did their best. Lets leave the hate. Racism isn't the answer either. #eurofinal #Euro2021
Any other @RSprachrohr #Rammstein fans randomly had their merch orders cancelled??	It is not sarcastic
What emojis (if any) would you add to this tweet?	Any other @RSprachrohr #Rammstein fans randomly had their merch orders cancelled??
@tedcruz @Dream worst timeline	It is sarcastic
What emojis (if any) would you add to this tweet?	@tedcruz @Dream worst timeline
Do you have any comments you would like to make?	

Participant Number	50
Question	Response
Qualification questions	
Consent to participate.	Yes
Are you over 18?	Yes
Do you use emojis?	Yes

Demographic Questions	
What is your gender?	Female
What age are you?	25-34
What is sarcasm?	a form of irony
Emoji Usage Questions	
The villains in super hero films are awfully polite. They always confine their invasions to being above one particular city	It is not sarcastic
What emojis (if any) would you add to this tweet?	The villains in super hero films are awfully polite. They always confine their invasions to being above one particular city 🤔
finished the queen's gambit, i loved a look into the 1960s in the american south with no racism just vibes	It is sarcastic
What emojis (if any) would you add to this tweet?	finished the queen's gambit, i loved a look into the 1960s in the american south with no racism just vibes 😂
Wow its almost like we dont nap every single day at the exact same time wow how dare I try to do the thing we do every single day! 🤔	It is sarcastic
What emojis (if any) would you add to this tweet?	Wow its almost like we dont nap every single day at the exact same time wow how dare I try to do the thing we do every single day! 🤔
Frankie is so lucky to have some amazing people in his life. Those that havent bothered are missing out!	It is not sarcastic
What emojis (if any) would you add to this tweet?	Frankie is so lucky to have some amazing people in his life. Those that havent bothered are missing out! ❤️
So I can go the pub have a meal, go to the cinema, hairdressers and a shopping spree, yet wont be allowed to see family/friends;let them meet my newborn baby?	It is not sarcastic
What emojis (if any) would you add to this tweet?	So I can go the pub have a meal, go to the cinema, hairdressers and a shopping spree, yet wont be allowed to see family/friends;let them meet my newborn baby? 🤔
@raerenyse Easily one of the worst and most damaging takes for both trans AND cis women I have seen thus far. Congrats on reaching new levels of awful lmao	It is not sarcastic

What emojis (if any) would you add to this tweet?	@raerenyse Easily one of the worst and most damaging takes for both trans AND cis women I have seen thus far. Congrats on reaching new levels of awful lmao 🤔
Here comes the final of the UK #DailyBriefing - who will win, Johnson or Covid?	It is sarcastic
What emojis (if any) would you add to this tweet?	Here comes the final of the UK #DailyBriefing - who will win, Johnson or Covid? 😏
Everyone - Get Vaccinated	It is not sarcastic
What emojis (if any) would you add to this tweet?	Everyone - Get Vaccinated 👍
E10 petrol in the UK, classic car scene is about to die.	I don't know
What emojis (if any) would you add to this tweet?	E10 petrol in the UK, classic car scene is about to die.
"You're not a normal white girl" lol ok	It is sarcastic
What emojis (if any) would you add to this tweet?	"You're not a normal white girl" lol ok 😏
Do you have any comments you would like to make?	

Participant Number	51
Question	Response
Qualification questions	
Consent to participate.	Yes
Are you over 18?	Yes
Do you use emojis?	Yes
Demographic Questions	
What is your gender?	Female
What age are you?	25-34
What is sarcasm?	When you say a joke in a non serious way

Emoji Usage Questions	
dont you love it when youre just chilling in your room and then theres a spider and you kill it but when you kill it you spill soda all over your keyboard yeah me too	It is sarcastic
What emojis (if any) would you add to this tweet?	dont you love it when youre just chilling in your room and then theres a spider and you kill it but when you kill it you spill soda all over your keyboard yeah me too 🤔
@Daniellngolfur @The_Timbrodini @ViQueen55 @tedcruz I know, right? He even wanted poor people to be healthy, because he was basically a fucking communist. What a hippie.	It is not sarcastic
What emojis (if any) would you add to this tweet?	@Daniellngolfur @The_Timbrodini @ViQueen55 @tedcruz I know, right? He even wanted poor people to be healthy, because he was basically a fucking communist. What a hippie.
If you ever wanted to know what it feels like to have dyslexia I would recommend the book House of Leaves. 📖	It is not sarcastic
What emojis (if any) would you add to this tweet?	If you ever wanted to know what it feels like to have dyslexia I would recommend the book House of Leaves. 📖
when I was younger I used to think that time zones also could change by minutes and people in other towns could be in 12:56 while I was in 1:14	It is not sarcastic
What emojis (if any) would you add to this tweet?	when I was younger I used to think that time zones also could change by minutes and people in other towns could be in 12:56 while I was in 1:14 🐒
dogs and cats are happy animals. i pity anyone who cannot love upon these magical created because of allergies. only heathens dislike them. i cannot be a part of a friendship where the alternate person has even the slightest disinterest in them.	It is not sarcastic
What emojis (if any) would you add to this tweet?	dogs and cats are happy animals. i pity anyone who cannot love upon these magical created because of allergies. only heathens dislike them. i cannot be a part of a friendship where the alternate person has even the slightest disinterest in them.

Don't let people walk all over you. Or breathe on you. Either one. 🗑️	It is sarcastic
What emojis (if any) would you add to this tweet?	Don't let people walk all over you. Or breathe on you. Either one. 🗑️
Kepa had a great game	I don't know
What emojis (if any) would you add to this tweet?	Kepa had a great game 😞
i just deleted every tweet from beyond this year because connor wouldnt stop asking for my cringy ass twitter damn	I don't know
What emojis (if any) would you add to this tweet?	i just deleted every tweet from beyond this year because connor wouldnt stop asking for my cringy ass twitter damn 😭
i just sewed through my finger and my brain is just like ' how annoying is it that i just broke another needle and i'm going to have to buy some more' instead of OW I have 2 holes in my finger. can i swap brains	I don't know
What emojis (if any) would you add to this tweet?	i just sewed through my finger and my brain is just like ' how annoying is it that i just broke another needle and i'm going to have to buy some more' instead of OW I have 2 holes in my finger. can i swap brains 😞
I am starting off my day by watching a Dragons Den special on Deborah Meaden and eating a Pot Noodle. My life is perfect.	It is sarcastic
What emojis (if any) would you add to this tweet?	I am starting off my day by watching a Dragons Den special on Deborah Meaden and eating a Pot Noodle. My life is perfect. 🗑️ 😞
Do you have any comments you would like to make?	interesting survey, I like it

Participant Number	52
Question	Response
Qualification questions	
Consent to participate.	Yes
Are you over 18?	Yes
Do you use emojis?	Yes

Demographic Questions	
What is your gender?	Female
What age are you?	18-24
What is sarcasm?	Irony
Emoji Usage Questions	
The villains in super hero films are awfully polite. They always confine their invasions to being above one particular city	It is sarcastic
What emojis (if any) would you add to this tweet?	The villains in super hero films are awfully polite. They always confine their invasions to being above one particular city 😏
when the toilet seat is warmed up for you	It is sarcastic
What emojis (if any) would you add to this tweet?	when the toilet seat is warmed up for you 😏
@PlayStationUK Nice	I don't know
What emojis (if any) would you add to this tweet?	@PlayStationUK Nice 😏
aw i had a dream i bought a big book of words and their meanings and now im awake and sad (also in the dream i was wondering around the most magical library/bookstore/gift shop???)	It is not sarcastic
What emojis (if any) would you add to this tweet?	aw i had a dream i bought a big book of words and their meanings and now im awake and sad (also in the dream i was wondering around the most magical library/bookstore/gift shop???) 😞
I want to join @IdenaNetwork to become a validator of the first Proof-Of-Person Blockchain #idenainvite	It is not sarcastic
What emojis (if any) would you add to this tweet?	I want to join @IdenaNetwork to become a validator of the first Proof-Of-Person Blockchain #idenainvite 😊
I cant wait to hear more about the life of an upper middle class East Asian American whose only personality trait is drinking boba tea https://t.co/SapbXLdOr2	It is sarcastic

What emojis (if any) would you add to this tweet?	I cant wait to hear more about the life of an upper middle class East Asian American whose only personality trait is drinking boba tea https://t.co/SapbXLd0r2 😊
Hey what's the weather like today? Am I going to need an umbrella?	It is not sarcastic
What emojis (if any) would you add to this tweet?	Hey what's the weather like today? Am I going to need an umbrella? 😊
"Join me on @WeAre8Official to help save our planet in just 2 minutes a day. #UnitedForGood @WeAre8Official https://t.co/s2LdOOJleR "	It is not sarcastic
What emojis (if any) would you add to this tweet?	"Join me on @WeAre8Official to help save our planet in just 2 minutes a day. #UnitedForGood @WeAre8Official https://t.co/s2LdOOJleR " 👍
@stereogum @ChemBros I swear I heard this sample way back as far as London 2012 opening ceremony??	It is sarcastic
What emojis (if any) would you add to this tweet?	@stereogum @ChemBros I swear I heard this sample way back as far as London 2012 opening ceremony?? 😊
trying to figure out how to use notion for my anime list. I think im dying	It is not sarcastic
What emojis (if any) would you add to this tweet?	trying to figure out how to use notion for my anime list. I think im dying 😭
Do you have any comments you would like to make?	Nothing to add

Participant Number	53
Question	Response
Qualification questions	
Consent to participate.	Yes
Are you over 18?	Yes
Do you use emojis?	Yes
Demographic Questions	
What is your gender?	Male
What age are you?	18-24
What is sarcasm?	Saying things that sound mean but are meant to be funny

Emoji Usage Questions	
Do you think anyone on Bachelor in Paradise has seen Oscar winner Parasite?	It is not sarcastic
What emojis (if any) would you add to this tweet?	Do you think anyone on Bachelor in Paradise has seen Oscar winner Parasite? 😞
"your pronouns are what's in your pants" ok. juicy/dumper	It is sarcastic
What emojis (if any) would you add to this tweet?	"your pronouns are what's in your pants" ok. juicy/dumper 😞
@wfcouncil Hi there, I'm told by the staff at fellowship square on this hot day that there is no cold water provision to full up reusable bottles unless I want to fill up "from the toilet" , is that actually my only option?	I don't know
What emojis (if any) would you add to this tweet?	@wfcouncil Hi there, I'm told by the staff at fellowship square on this hot day that there is no cold water provision to full up reusable bottles unless I want to fill up "from the toilet" , is that actually my only option? 😞
In terms of usability is there a more frustrating web site than ebay?	It is sarcastic
What emojis (if any) would you add to this tweet?	In terms of usability is there a more frustrating web site than ebay? 😞
Its so amazing how people forget you exist until they want something from you :,)	It is sarcastic
What emojis (if any) would you add to this tweet?	Its so amazing how people forget you exist until they want something from you :,) 😞
"2 things I love: 1. Being woken up by construction work an hour before my alarm. 2. Sarcasm."	It is sarcastic
What emojis (if any) would you add to this tweet?	"2 things I love: 1. Being woken up by construction work an hour before my alarm. 2. Sarcasm." 😞
First proper Coffee in 4 months. 😞	It is not sarcastic
What emojis (if any) would you add to this tweet?	First proper Coffee in 4 months. 😞

Broadband back, starting to feel a bit more normal.	It is sarcastic
What emojis (if any) would you add to this tweet?	Broadband back, starting to feel a bit more normal. 😡
How bout you dont use a gazillion filters on your pictures	It is sarcastic
What emojis (if any) would you add to this tweet?	How bout you dont use a gazillion filters on your pictures 😏
finished the queen's gambit, i loved a look into the 1960s in the american south with no racism just vibes	It is sarcastic
What emojis (if any) would you add to this tweet?	finished the queen's gambit, i loved a look into the 1960s in the american south with no racism just vibes 😏
Do you have any comments you would like to make?	

Participant Number	54
Question	Response
Qualification questions	
Consent to participate.	Yes
Are you over 18?	Yes
Do you use emojis?	Yes
Demographic Questions	
What is your gender?	Male
What age are you?	35-44
What is sarcasm?	making fun indirectly
Emoji Usage Questions	
Wow its almost like we dont nap every single day at the exact same time wow how dare I try to do the thing we do every single day!	It is not sarcastic
What emojis (if any) would you add to this tweet?	Wow its almost like we dont nap every single day at the exact same time wow how dare I try to do the thing we do every single day! 😏

Frankie is so lucky to have some amazing people in his life. Those that havent bothered are missing out!	It is sarcastic
What emojis (if any) would you add to this tweet?	Frankie is so lucky to have some amazing people in his life. Those that havent bothered are missing out! 😊
So I can go the pub have a meal, go to the cinema, hairdressers and a shopping spree, yet wont be allowed to see family/friends;let them meet my newborn baby?	It is not sarcastic
What emojis (if any) would you add to this tweet?	So I can go the pub have a meal, go to the cinema, hairdressers and a shopping spree, yet wont be allowed to see family/friends;let them meet my newborn baby? 😡
@raerenyse Easily one of the worst and most damaging takes for both trans AND cis women I have seen thus far. Congrats on reaching new levels of awful lmao	It is sarcastic
What emojis (if any) would you add to this tweet?	@raerenyse Easily one of the worst and most damaging takes for both trans AND cis women I have seen thus far. Congrats on reaching new levels of awful lmao 😡
Here comes the final of the UK #DailyBriefing - who will win, Johnson or Covid?	It is sarcastic
What emojis (if any) would you add to this tweet?	Here comes the final of the UK #DailyBriefing - who will win, Johnson or Covid? 😊
Everyone - Get Vaccinated	It is sarcastic
What emojis (if any) would you add to this tweet?	Everyone - Get Vaccinated 😊
E10 petrol in the UK, classic car scene is about to die. 😞	I don't know
What emojis (if any) would you add to this tweet?	E10 petrol in the UK, classic car scene is about to die. 😞
"You're not a normal white girl" lol ok	It is sarcastic
What emojis (if any) would you add to this tweet?	"You're not a normal white girl" lol ok 😊

Do you have any comments you would like to make?	
--	--

Participant Number	55
Question	Response
Qualification questions	
Consent to participate.	Yes
Are you over 18?	Yes
Do you use emojis?	Yes
Demographic Questions	
What is your gender?	Female
What age are you?	35-44
What is sarcasm?	a snarkiness, darker form of irony
Emoji Usage Questions	
dont you love it when youre just chilling in your room and then theres a spider and you kill it but when you kill it you spill soda all over your keyboard yeah me too	It is sarcastic
What emojis (if any) would you add to this tweet?	dont you love it when youre just chilling in your room and then theres a spider and you kill it but when you kill it you spill soda all over your keyboard yeah me too 🤔
Thanks @Tesco for not informing me that my click and collect order had been cancelled when my account says it's ready to collect my partner has had to travel unnecessarily to Stafford and we still don't have our shopping, good diet I guess having to wait for my 26th delivery slot https://t.co/xq9oXEkw8o	It is sarcastic
What emojis (if any) would you add to this tweet?	Thanks @Tesco for not informing me that my click and collect order had been cancelled when my account says it's ready to collect my partner has had to travel unnecessarily to Stafford and we still don't have our shopping, good diet I guess having to wait for my 26th delivery slot https://t.co/xq9oXEkw8o
My dream is to be left alone.	It is not sarcastic
What emojis (if any) would you add to this tweet?	My dream is to be left alone.

@HarryrotterDB Yeah I'll probs try it out too.	It is not sarcastic
What emojis (if any) would you add to this tweet?	@HarryrotterDB Yeah I'll probs try it out too.
@DarkenerWoW @wochinimen @MissPurplePixie shit healer	It is not sarcastic
What emojis (if any) would you add to this tweet?	@DarkenerWoW @wochinimen @MissPurplePixie shit healer
@lora SHOCKED. How am I supposed to tell the kids they're not going to Disneyland on June 21st after all? It's already been cancelled 36 times! https://t.co/SV8gpPn6yw	It is sarcastic
What emojis (if any) would you add to this tweet?	@lora SHOCKED. How am I supposed to tell the kids they're not going to Disneyland on June 21st after all? It's already been cancelled 36 times! https://t.co/SV8gpPn6yw 😊
@BorisJohnson @MattHancock Oh really?	I don't know
What emojis (if any) would you add to this tweet?	@BorisJohnson @MattHancock Oh really?
@futboljacob @LFC @Thiago6 It literally says in the article that hes expected back next week.	It is not sarcastic
What emojis (if any) would you add to this tweet?	@futboljacob @LFC @Thiago6 It literally says in the article that hes expected back next week.
Living with a str*ight man is like living with a four year old	It is sarcastic
What emojis (if any) would you add to this tweet?	Living with a str*ight man is like living with a four year old
love when the train stops in philly and everybody boards and of a sudden it smells like a ham sandwich	It is sarcastic
What emojis (if any) would you add to this tweet?	love when the train stops in philly and everybody boards and of a sudden it smells like a ham sandwich
Do you have any comments you would like to make?	no

Participant Number	56
Question	Response
Qualification questions	
Consent to participate.	Yes
Are you over 18?	Yes
Do you use emojis?	Yes
Demographic Questions	
What is your gender?	Male
What age are you?	25-34
What is sarcasm?	When you say the opposite of what you mean in a joking way
Emoji Usage Questions	
dont you love it when youre just chilling in your room and then theres a spider and you kill it but when you kill it you spill soda all over your keyboard yeah me too	It is sarcastic
What emojis (if any) would you add to this tweet?	dont you love it when youre just chilling in your room and then theres a spider and you kill it but when you kill it you spill soda all over your keyboard yeah me too 🙄
Thanks @Tesco for not informing me that my click and collect order had been cancelled when my account says it's ready to collect my partner has had to travel unnecessarily to Stafford and we still don't have our shopping, good diet I guess having to wait for my 26th delivery slot https://t.co/xq9oXEkw8o	It is not sarcastic
What emojis (if any) would you add to this tweet?	Thanks @Tesco for not informing me that my click and collect order had been cancelled when my account says it's ready to collect my partner has had to travel unnecessarily to Stafford and we still don't have our shopping, good diet I guess having to wait for my 26th delivery slot https://t.co/xq9oXEkw8o 😡
My dream is to be left alone.	It is not sarcastic
What emojis (if any) would you add to this tweet?	My dream is to be left alone. 🙄

@HarryrotterDB Yeah I'll probs try it out too.	It is sarcastic
What emojis (if any) would you add to this tweet?	@HarryrotterDB Yeah I'll probs try it out too. 😞
@DarkenerWoW @wochinimen @MissPurplePixie shit healer	It is not sarcastic
What emojis (if any) would you add to this tweet?	@DarkenerWoW @wochinimen @MissPurplePixie shit healer
@lora SHOCKED. How am I supposed to tell the kids they're not going to Disneyland on June 21st after all? It's already been cancelled 36 times! https://t.co/SV8gpPn6yw	It is sarcastic
What emojis (if any) would you add to this tweet?	@lora SHOCKED. How am I supposed to tell the kids they're not going to Disneyland on June 21st after all? It's already been cancelled 36 times! https://t.co/SV8gpPn6yw
@BorisJohnson @MattHancock Oh really?	I don't know
What emojis (if any) would you add to this tweet?	@BorisJohnson @MattHancock Oh really?
@futboljacob @LFC @Thiago6 It literally says in the article that hes expected back next week.	It is not sarcastic
What emojis (if any) would you add to this tweet?	@futboljacob @LFC @Thiago6 It literally says in the article that hes expected back next week.
Living with a str*ight man is like living with a four year old	It is not sarcastic
What emojis (if any) would you add to this tweet?	Living with a str*ight man is like living with a four year old
love when the train stops in philly and everybody boards and of a sudden it smells like a ham sandwich	It is sarcastic
What emojis (if any) would you add to this tweet?	love when the train stops in philly and everybody boards and of a sudden it smells like a ham sandwich ❤️
Do you have any comments you would like to make?	

Participant Number	57
Question	Response
Qualification questions	
Consent to participate.	Yes
Are you over 18?	Yes
Do you use emojis?	Yes
Demographic Questions	
What is your gender?	Female
What age are you?	18-24
What is sarcasm?	When someone tells a joke without nonverbal cues to indicate that they're kidding
Emoji Usage Questions	
dont you love it when youre just chilling in your room and then theres a spider and you kill it but when you kill it you spill soda all over your keyboard yeah me too	It is sarcastic
What emojis (if any) would you add to this tweet?	dont you love it when youre just chilling in your room and then theres a spider and you kill it but when you kill it you spill soda all over your keyboard yeah me too 😬👍
Thanks @Tesco for not informing me that my click and collect order had been cancelled when my account says it's ready to collect my partner has had to travel unnecessarily to Stafford and we still don't have our shopping, good diet I guess having to wait for my 26th delivery slot https://t.co/xq9oXEkw8o	It is not sarcastic
What emojis (if any) would you add to this tweet?	Thanks @Tesco for not informing me that my click and collect order had been cancelled when my account says it's ready to collect my partner has had to travel unnecessarily to Stafford and we still don't have our shopping, good diet I guess having to wait for my 26th delivery slot https://t.co/xq9oXEkw8o
My dream is to be left alone.	It is not sarcastic
What emojis (if any) would you add to this tweet?	My dream is to be left alone.
@HarryrotterDB Yeah I'll probs try it out too.	It is not sarcastic

What emojis (if any) would you add to this tweet? @DarkenerWoW @wochinimen @MissPurplePixie shit healer	@HarryrotterDB Yeah I'll probs try it out too. It is not sarcastic
What emojis (if any) would you add to this tweet? @lora SHOCKED. How am I supposed to tell the kids they're not going to Disneyland on June 21st after all? It's already been cancelled 36 times! https://t.co/SV8gpPn6yw	@DarkenerWoW @wochinimen @MissPurplePixie shit healer It is not sarcastic
What emojis (if any) would you add to this tweet? @BorisJohnson @MattHancock Oh really?	@lora SHOCKED. How am I supposed to tell the kids they're not going to Disneyland on June 21st after all? It's already been cancelled 36 times! https://t.co/SV8gpPn6yw I don't know
What emojis (if any) would you add to this tweet? @futboljacob @LFC @Thiago6 It literally says in the article that hes expected back next week.	@BorisJohnson @MattHancock Oh really? It is not sarcastic
What emojis (if any) would you add to this tweet? Living with a str*ight man is like living with a four year old	@futboljacob @LFC @Thiago6 It literally says in the article that hes expected back next week. It is not sarcastic
What emojis (if any) would you add to this tweet? love when the train stops in philly and everybody boards and of a sudden it smells like a ham sandwich	Living with a str*ight man is like living with a four year old It is sarcastic
What emojis (if any) would you add to this tweet? Do you have any comments you would like to make?	love when the train stops in philly and everybody boards and of a sudden it smells like a ham sandwich 🤢🤮

Participant Number	58
Question	Response

Qualification questions	
Consent to participate.	Yes
Are you over 18?	Yes
Do you use emojis?	Yes
Demographic Questions	
What is your gender?	Female
What age are you?	18-24
What is sarcasm?	https://en.wikipedia.org/wiki/Sarcasm
Emoji Usage Questions	
dont you love it when youre just chilling in your room and then theres a spider and you kill it but when you kill it you spill soda all over your keyboard yeah me too	It is sarcastic
What emojis (if any) would you add to this tweet?	dont you love it when youre just chilling in your room and then theres a spider and you kill it but when you kill it you spill soda all over your keyboard yeah me too 😂
first game not starting when it's supposed to? a UCF tradition	It is sarcastic
What emojis (if any) would you add to this tweet?	👍 first game not starting when it's supposed to? a UCF tradition
im about to just walk into a place and start working then and there and they'll have no choice but to hire me on the spot	It is sarcastic
What emojis (if any) would you add to this tweet?	😏 im about to just walk into a place and start working then and there and they'll have no choice but to hire me on the spot
Beautiful animation and hype song what more could be asked for https://t.co/PFLLswgkh3	It is sarcastic
What emojis (if any) would you add to this tweet?	😏 Beautiful animation and hype song what more could be asked for https://t.co/PFLLswgkh3
APPLE CIDER IS BACK AT DUNKS BABY	It is not sarcastic
What emojis (if any) would you add to this tweet?	APPLE CIDER IS BACK AT DUNKS BABY
just stuck my entire hand in a hot oven without thinking about the consequences. self preservation is clearly my strong suit	It is sarcastic
What emojis (if any) would you add to this tweet?	😂 just stuck my entire hand in a hot oven without thinking about the consequences. self preservation is clearly my strong suit

Turnover is the best band to cry to/drive to/daydream to/fall asleep to/ reminisce to/die to	It is not sarcastic
What emojis (if any) would you add to this tweet?	Turnover is the best band to cry to/drive to/daydream to/fall asleep to/ reminisce to/die to
i cant wait to leave boston	It is not sarcastic
What emojis (if any) would you add to this tweet?	i cant wait to leave boston
this is the first time in 6 years i havent had to move, i am so relieved	It is sarcastic
What emojis (if any) would you add to this tweet?	😬 this is the first time in 6 years i havent had to move, i am so relieved
Congratulations to Trump on his second impeachment. Its a tremendous achievement borne of hard work, focus and dedication. Record breaking. Historic. Bigly. #ImpeachmentDay #TrumpImpeachment2	It is sarcastic
What emojis (if any) would you add to this tweet?	👍 Congratulations to Trump on his second impeachment. Its a tremendous achievement borne of hard work, focus and dedication. Record breaking. Historic. Bigly. #ImpeachmentDay #TrumpImpeachment2
Do you have any comments you would like to make?	

Participant Number	59
Question	Response
Qualification questions	
Consent to participate.	Yes
Are you over 18?	Yes
Do you use emojis?	Yes
Demographic Questions	
What is your gender?	Female
What age are you?	25-34
What is sarcasm?	Saying something while meaning another thing, and indicating it with your tone, usually as a way to make a joke or make fun of something.
Emoji Usage Questions	

dont you love it when youre just chilling in your room and then theres a spider and you kill it but when you kill it you spill soda all over your keyboard yeah me too	It is sarcastic
What emojis (if any) would you add to this tweet?	dont you love it when youre just chilling in your room and then theres a spider and you kill it but when you kill it you spill soda all over your keyboard yeah me too 🤔
tit for tat, butter for fat, you kill my dog, i eat your cat is a liberian proverb for an eye for an eye. my ancestors were spittin	It is not sarcastic
What emojis (if any) would you add to this tweet?	tit for tat, butter for fat, you kill my dog, i eat your cat is a liberian proverb for an eye for an eye. my ancestors were spittin 🐱🐶
@Chris_Ransom @CityView1904 @Uzzell01 @BBCSport Aware she was not a tennis player when she left Canada at 2 yrs old?? aware she did not pick up a tennis racket until 6 years old??.aware last12 years trained at the same tennis club in Bromley Kent England??the girl is British no haters or doubters will take that away from her GB	It is not sarcastic
What emojis (if any) would you add to this tweet?	@Chris_Ransom @CityView1904 @Uzzell01 @BBCSport Aware she was not a tennis player when she left Canada at 2 yrs old?? aware she did not pick up a tennis racket until 6 years old??.aware last12 years trained at the same tennis club in Bromley Kent England??the girl is British no haters or doubters will take that away from her GB
Ive decided that Im ready for the Schrute Farms offshoot show now.	It is sarcastic
What emojis (if any) would you add to this tweet?	Ive decided that Im ready for the Schrute Farms offshoot show now.
You know you live in a city when you refer to crumbs as roach snacks.	It is sarcastic
What emojis (if any) would you add to this tweet?	You know you live in a city when you refer to crumbs as roach snacks. 🐛🐛
was not aware that Crocs were appropriate business casual attire.	It is sarcastic
What emojis (if any) would you add to this tweet?	was not aware that Crocs were appropriate business casual attire.
"On a scale from 1 to 10 how deeply was your childhood influenced by the Hannah Montana 2: Meet Miley Cyrus double album? This is for research purposes."	It is not sarcastic

What emojis (if any) would you add to this tweet?	"On a scale from 1 to 10 how deeply was your childhood influenced by the Hannah Montana 2: Meet Miley Cyrus double album? This is for research purposes."
@FeeyaCruz But you get to see me?!	It is not sarcastic
What emojis (if any) would you add to this tweet?	@FeeyaCruz But you get to see me?!
Anyone selling a parklife weekend ticket??	It is not sarcastic
What emojis (if any) would you add to this tweet?	Anyone selling a parklife weekend ticket??
Oh? You're a real anime fan? Name all the Boku no Pico characters, I'll wait.	It is sarcastic
What emojis (if any) would you add to this tweet?	Oh? You're a real anime fan? Name all the Boku no Pico characters, I'll wait.
Do you have any comments you would like to make?	

Participant Number	60
Question	Response
Qualification questions	
Consent to participate.	Yes
Are you over 18?	Yes
Do you use emojis?	Yes
Demographic Questions	
What is your gender?	Queer
What age are you?	18-24
What is sarcasm?	Sarcasm is a kind of dry humour
Emoji Usage Questions	
dont you love it when youre just chilling in your room and then theres a spider and you kill it but when you kill it you spill soda all over your keyboard yeah me too	It is sarcastic

What emojis (if any) would you add to this tweet?	dont you love it when youre just chilling in your room and then theres a spider and you kill it but when you kill it you spill soda all over your keyboard yeah me too 😊😁😂😃😄😅
The fact I nearly froze on my way to work this morning is definitely a sign it's not summer anymore #freezing	It is not sarcastic
What emojis (if any) would you add to this tweet?	The fact I nearly froze on my way to work this morning is definitely a sign it's not summer anymore #freezing 😊😓😭😬
"Damn, imagine being vaxxed and then getting a cold and then losing your taste and smell. Oh wait."	It is sarcastic
What emojis (if any) would you add to this tweet?	"Damn, imagine being vaxxed and then getting a cold and then losing your taste and smell. Oh wait." 😞😐😏😓😭
All this extra time and Im still not flossing	It is not sarcastic
What emojis (if any) would you add to this tweet?	All this extra time and Im still not flossing 😊😓😏😐
If a dude says females I automatically dont trust him	It is not sarcastic
What emojis (if any) would you add to this tweet?	If a dude says females I automatically dont trust him 😞😓😏😐😄😅
Is this first Cybex isokinetic dynamometer? @DrAndrewBateman #PRS2021	I don't know
What emojis (if any) would you add to this tweet?	Is this first Cybex isokinetic dynamometer? @DrAndrewBateman #PRS2021
Worked out 2 days in a row. I am quite literally the epitome of health and fitness	It is sarcastic
What emojis (if any) would you add to this tweet?	Worked out 2 days in a row. I am quite literally the epitome of health and fitness 😊😓👉
Sometimes I think Im ready to live in an apartment either with the homies or by myself but then someone rings the doorbell and I get into a full blown anxiety attack because I think its someone trying to kill me lmao	It is not sarcastic

What emojis (if any) would you add to this tweet?	Sometimes I think Im ready to live in an apartment either with the homies or by myself but then someone rings the doorbell and I get into a full blown anxiety attack because I think its someone trying to kill me lmao 🤪🤔🤔
Ive just spent 6 hours watching minecraft streamers instead of doing my homework I have no regrets	It is not sarcastic
What emojis (if any) would you add to this tweet?	Ive just spent 6 hours watching minecraft streamers instead of doing my homework I have no regrets 🤪🤔🤔
yes i have little interest in doing things that applies to me	It is not sarcastic
What emojis (if any) would you add to this tweet?	yes i have little interest in doing things that applies to me
Do you have any comments you would like to make?	

Participant Number	61
Question	Response
Qualification questions	
Consent to participate.	Yes
Are you over 18?	Yes
Do you use emojis?	Yes
Demographic Questions	
What is your gender?	Male
What age are you?	35-44
What is sarcasm?	use of irony for mockery
Emoji Usage Questions	
dont you love it when youre just chilling in your room and then theres a spider and you kill it but when you kill it you spill soda all over your keyboard yeah me too 🤪	It is sarcastic
What emojis (if any) would you add to this tweet?	dont you love it when youre just chilling in your room and then theres a spider and you kill it but when you kill it you spill soda all over your keyboard yeah me too 🤪

Sitting next to the world's loudest mouth-breather on the first day of class did a really good job of demystifying grad school for me today	It is sarcastic
What emojis (if any) would you add to this tweet?	Sitting next to the world's loudest mouth-breather on the first day of class did a really good job of demystifying grad school for me today
yeah i enjoy some oregano on a nice pasta dinner (dumps oregano on mac n cheese)	It is sarcastic
What emojis (if any) would you add to this tweet?	yeah i enjoy some oregano on a nice pasta dinner (dumps oregano on mac n cheese)
i love acknowledging the other twinks on campus hi friends!!	It is not sarcastic
What emojis (if any) would you add to this tweet?	i love acknowledging the other twinks on campus hi friends!!
it takes 2 minutes for me to paint my nails so sometimes i do it impulsively and then sit there looking at my hands like fuck i have things to do rn	It is not sarcastic
What emojis (if any) would you add to this tweet?	it takes 2 minutes for me to paint my nails so sometimes i do it impulsively and then sit there looking at my hands like fuck i have things to do rn
every date I go on I get a little scared will be phone swap	It is not sarcastic
What emojis (if any) would you add to this tweet?	every date I go on I get a little scared will be phone swap
"Blatantly obvious that Lionel Messi is now set for a move to Leeds. The Newells old boys network."	It is not sarcastic
What emojis (if any) would you add to this tweet?	"Blatantly obvious that Lionel Messi is now set for a move to Leeds. The Newells old boys network."
i want thai food Right Now :(It is not sarcastic
What emojis (if any) would you add to this tweet?	i want thai food Right Now :(

Is it just me, or do they keep taking The Associate on and off Netflix...	It is not sarcastic
What emojis (if any) would you add to this tweet?	Is it just me, or do they keep taking The Associate on and off Netflix...
"Cant wait to get home take a big ass antihistamine and roll in some topical steroids. Damn it, skin! What did I ever do to you?!?!"	It is not sarcastic
What emojis (if any) would you add to this tweet?	"Cant wait to get home take a big ass antihistamine and roll in some topical steroids. Damn it, skin! What did I ever do to you?!?!"
Do you have any comments you would like to make?	

Participant Number	62
Question	Response
Qualification questions	
Consent to participate.	Yes
Are you over 18?	Yes
Do you use emojis?	Yes
Demographic Questions	
What is your gender?	Female
What age are you?	25-34
What is sarcasm?	Saying something you mean the opposite of
Emoji Usage Questions	
don't you love it when you're just chilling in your room and then there's a spider and you kill it but when you kill it you spill soda all over your keyboard??? yeah me too	It is sarcastic
What emojis (if any) would you add to this tweet?	don't you love it when you're just chilling in your room and then there's a spider and you kill it but when you kill it you spill soda all over your keyboard??? yeah me too
Just signed up for Apple's Ping, told it I like 'classical' and it points me towards Lady Gaga. It takes a certain genius to be this crap.	It is not sarcastic
What emojis (if any) would you add to this tweet?	Just signed up for Apple's Ping, told it I like 'classical' and it points me towards Lady Gaga. It takes a certain genius to be this crap.

Just redownloaded the @achievement app - let's see if it improves my exercise routine!	It is not sarcastic
What emojis (if any) would you add to this tweet?	Just redownloaded the @achievement app - let's see if it improves my exercise routine!
my favorite brand of old people are the ones who work as tour guides at national parks	It is not sarcastic
What emojis (if any) would you add to this tweet?	my favorite brand of old people are the ones who work as tour guides at national parks 🧡
yesterday 4 dinner I just had rice w/ sriracha sauce on it and it was arguably the best meal I've had in a while	It is not sarcastic
What emojis (if any) would you add to this tweet?	yesterday 4 dinner I just had rice w/ sriracha sauce on it and it was arguably the best meal I've had in a while
im going to cut off contact with every single person i know and emerge in a few months o a year from now having lost the ability to physically speak but be able to play the meanest fucking accordion youve ever heard in your pathetic little life	It is not sarcastic
What emojis (if any) would you add to this tweet?	im going to cut off contact with every single person i know and emerge in a few months o a year from now having lost the ability to physically speak but be able to play the meanest fucking accordion youve ever heard in your pathetic little life
Its funny that you guys thought sports mattered during a pandemic. I simply can not imagine caring about a winning streak rn.	It is not sarcastic
What emojis (if any) would you add to this tweet?	Its funny that you guys thought sports mattered during a pandemic. I simply can not imagine caring about a winning streak rn. 😞
why was suite life on deck not called zack and cody on a boaty??? missed opportunity	It is not sarcastic
What emojis (if any) would you add to this tweet?	why was suite life on deck not called zack and cody on a boaty??? missed opportunity
excited to start my new hobby of standing in the lgbtq section of the feminist bookstore and look hot and mysterious until I get noticed	It is not sarcastic

What emojis (if any) would you add to this tweet?	excited to start my new hobby of standing in the lgbtq section of the feminist bookstore and look hot and mysterious until I get noticed
ah yes, of the course the summer rain pours when im on foot.	I don't know
What emojis (if any) would you add to this tweet?	ah yes, of the course the summer rain pours when im on foot. 😊
Do you have any comments you would like to make?	no

Participant Number	63
Question	Response
Qualification questions	
Consent to participate.	Yes
Are you over 18?	Yes
Do you use emojis?	Yes
Demographic Questions	
What is your gender?	Female
What age are you?	35-44
What is sarcasm?	When you want to insult someone without getting in trouble so make it out to be a joke
Emoji Usage Questions	
dont you love it when youre just chilling in your room and then theres a spider and you kill it but when you kill it you spill soda all over your keyboard yeah me too	It is sarcastic
What emojis (if any) would you add to this tweet?	dont you love it when youre just chilling in your room and then theres a spider and you kill it but when you kill it you spill soda all over your keyboard yeah me too 🙄
Just signed up for Apple's Ping, told it I like 'classical' and it points me towards Lady Gaga. It takes a certain genius to be this crap.	It is sarcastic
What emojis (if any) would you add to this tweet?	Just signed up for Apple's Ping, told it I like 'classical' and it points me towards Lady Gaga. It takes a certain genius to be this crap. 😏

Just redownloaded the @achievement app - let's see if it improves my exercise routine!	It is not sarcastic
What emojis (if any) would you add to this tweet?	Just redownloaded the @achievement app - let's see if it improves my exercise routine! 👍👍👍
my favorite brand of old people are the ones who work as tour guides at national parks	It is not sarcastic
What emojis (if any) would you add to this tweet?	my favorite brand of old people are the ones who work as tour guides at national parks 😏😏❤️
yesterday 4 dinner I just had rice w/ sriracha sauce on it and it was arguably the best meal I've had in a while	It is not sarcastic
What emojis (if any) would you add to this tweet?	yesterday 4 dinner I just had rice w/ sriracha sauce on it and it was arguably the best meal I've had in a while 🍴
im going to cut off contact with every single person i know and emerge in a few months o a year from now having lost the ability to physically speak but be able to play the meanest fucking accordion youve ever heard in your pathetic little life	I don't know
What emojis (if any) would you add to this tweet?	im going to cut off contact with every single person i know and emerge in a few months o a year from now having lost the ability to physically speak but be able to play the meanest fucking accordion youve ever heard in your pathetic little life
Its funny that you guys thought sports mattered during a pandemic. I simply can not imagine caring about a winning streak rn.	It is not sarcastic
What emojis (if any) would you add to this tweet?	Its funny that you guys thought sports mattered during a pandemic. I simply can not imagine caring about a winning streak rn.
why was suite life on deck not called zack and cody on a boaty??? missed opportunity	It is not sarcastic
What emojis (if any) would you add to this tweet?	why was suite life on deck not called zack and cody on a boaty??? missed opportunity

excited to start my new hobby of standing in the lgbtq section of the feminist bookstore and look hot and mysterious until I get noticed	It is not sarcastic
What emojis (if any) would you add to this tweet?	excited to start my new hobby of standing in the lgbtq section of the feminist bookstore and look hot and mysterious until I get noticed
ah yes, of the course the summer rain pours when im on foot.	It is sarcastic
What emojis (if any) would you add to this tweet?	ah yes, of the course the summer rain pours when im on foot.
Do you have any comments you would like to make?	

Participant Number	64
Question	Response
Qualification questions	
Consent to participate.	Yes
Are you over 18?	Yes
Do you use emojis?	Yes
Demographic Questions	
What is your gender?	Female
What age are you?	35-44
What is sarcasm?	Mean spirited jokes
Emoji Usage Questions	
dont you love it when youre just chilling in your room and then theres a spider and you kill it but when you kill it you spill soda all over your keyboard yeah me too 🤔👍	It is sarcastic
What emojis (if any) would you add to this tweet?	dont you love it when youre just chilling in your room and then theres a spider and you kill it but when you kill it you spill soda all over your keyboard yeah me too
Just signed up for Apple's Ping, told it I like 'classical' and it points me towards Lady Gaga. It takes a certain genius to be this crap.	I don't know
What emojis (if any) would you add to this tweet?	Just signed up for Apple's Ping, told it I like 'classical' and it points me towards Lady Gaga. It takes a certain genius to be this crap.

Just redownloaded the @achievement app - let's see if it improves my exercise routine!	I don't know
What emojis (if any) would you add to this tweet?	Just redownloaded the @achievement app - let's see if it improves my exercise routine!
my favorite brand of old people are the ones who work as tour guides at national parks	It is not sarcastic
What emojis (if any) would you add to this tweet?	my favorite brand of old people are the ones who work as tour guides at national parks 😊
yesterday 4 dinner I just had rice w/ sriracha sauce on it and it was arguably the best meal I've had in a while	I don't know
What emojis (if any) would you add to this tweet?	yesterday 4 dinner I just had rice w/ sriracha sauce on it and it was arguably the best meal I've had in a while
im going to cut off contact with every single person i know and emerge in a few months o a year from now having lost the ability to physically speak but be able to play the meanest fucking accordion youve ever heard in your pathetic little life	I don't know
What emojis (if any) would you add to this tweet?	im going to cut off contact with every single person i know and emerge in a few months o a year from now having lost the ability to physically speak but be able to play the meanest fucking accordion youve ever heard in your pathetic little life 😊
Its funny that you guys thought sports mattered during a pandemic. I simply can not imagine caring about a winning streak rn.	It is not sarcastic
What emojis (if any) would you add to this tweet?	Its funny that you guys thought sports mattered during a pandemic. I simply can not imagine caring about a winning streak rn. 😊
why was suite life on deck not called zack and cody on a boaty??? missed opportunity	It is not sarcastic
What emojis (if any) would you add to this tweet?	why was suite life on deck not called zack and cody on a boaty??? missed opportunity 😊
excited to start my new hobby of standing in the lgbtq section of the feminist bookstore and look hot and mysterious until I get noticed	It is sarcastic

What emojis (if any) would you add to this tweet?	excited to start my new hobby of standing in the lgbtq section of the feminist bookstore and look hot and mysterious until I get noticed 😊
ah yes, of the course the summer rain pours when im on foot.	It is sarcastic
What emojis (if any) would you add to this tweet?	ah yes, of the course the summer rain pours when im on foot. 😞
Do you have any comments you would like to make?	

Participant Number	65
Question	Response
Qualification questions	
Consent to participate.	Yes
Are you over 18?	Yes
Do you use emojis?	Yes
Demographic Questions	
What is your gender?	Female
What age are you?	18-24
What is sarcasm?	Putting someone down using a form of irony
Emoji Usage Questions	
dont you love it when youre just chilling in your room and then theres a spider and you kill it but when you kill it you spill soda all over your keyboard yeah me too	It is sarcastic
What emojis (if any) would you add to this tweet?	dont you love it when youre just chilling in your room and then theres a spider and you kill it but when you kill it you spill soda all over your keyboard yeah me too 👍
Thanks @Tesco for not informing me that my click and collect order had been cancelled when my account says it's ready to collect my partner has had to travel unnecessarily to Stafford and we still don't have our shopping, good diet I guess having to wait for my 26th delivery slot https://t.co/xq9oXEkw8o	It is sarcastic
What emojis (if any) would you add to this tweet?	Thanks @Tesco for not informing me that my click and collect order had been cancelled when my account says it's ready to collect my

	partner has had to travel unnecessarily to Stafford and we still don't have our shopping, good diet I guess having to wait for my 26th delivery slot https://t.co/xq9oXEkw8o 😞
My dream is to be left alone.	It is not sarcastic
What emojis (if any) would you add to this tweet?	My dream is to be left alone. ❤️
@HarryrotterDB Yeah I'll probs try it out too.	It is not sarcastic
What emojis (if any) would you add to this tweet?	@HarryrotterDB Yeah I'll probs try it out too.
@DarkenerWoW @wochinimen @MissPurplePixie shit healer	I don't know
What emojis (if any) would you add to this tweet?	@DarkenerWoW @wochinimen @MissPurplePixie shit healer
@lora SHOCKED. How am I supposed to tell the kids they're not going to Disneyland on June 21st after all? It's already been cancelled 36 times! https://t.co/SV8gpPn6yw	It is sarcastic
What emojis (if any) would you add to this tweet?	@lora SHOCKED. How am I supposed to tell the kids they're not going to Disneyland on June 21st after all? It's already been cancelled 36 times! https://t.co/SV8gpPn6yw 😱
@BorisJohnson @MattHancock Oh really?	I don't know
What emojis (if any) would you add to this tweet?	@BorisJohnson @MattHancock Oh really?
@futboljacob @LFC @Thiago6 It literally says in the article that hes expected back next week.	It is not sarcastic
What emojis (if any) would you add to this tweet?	@futboljacob @LFC @Thiago6 It literally says in the article that hes expected back next week.
Living with a str*ight man is like living with a four year old	It is not sarcastic

What emojis (if any) would you add to this tweet?	Living with a str*ight man is like living with a four year old 😞
love when the train stops in philly and everybody boards and of a sudden it smells like a ham sandwich	It is sarcastic
What emojis (if any) would you add to this tweet?	love when the train stops in philly and everybody boards and of a sudden it smells like a ham sandwich 😞
Do you have any comments you would like to make?	

Participant Number	66
Question	Response
Qualification questions	
Consent to participate.	Yes
Are you over 18?	Yes
Do you use emojis?	Yes
Demographic Questions	
What is your gender?	Male
What age are you?	45-64
What is sarcasm?	Insulting something/someone in a humorous way
Emoji Usage Questions	
Just signed up for Apple's Ping, told it I like 'classical' and it points me towards Lady Gaga. It takes a certain genius to be this crap.	It is sarcastic
What emojis (if any) would you add to this tweet?	Just signed up for Apple's Ping, told it I like 'classical' and it points me towards Lady Gaga. It takes a certain genius to be this crap.
Just redownloaded the @achievement app - let's see if it improves my exercise routine!	It is not sarcastic
What emojis (if any) would you add to this tweet?	Just redownloaded the @achievement app - let's see if it improves my exercise routine! 😊

my favorite brand of old people are the ones who work as tour guides at national parks	It is not sarcastic
What emojis (if any) would you add to this tweet?	my favorite brand of old people are the ones who work as tour guides at national parks 🍷
yesterday 4 dinner I just had rice w/ sriracha sauce on it and it was arguably the best meal I've had in a while	It is not sarcastic
What emojis (if any) would you add to this tweet?	yesterday 4 dinner I just had rice w/ sriracha sauce on it and it was arguably the best meal I've had in a while
im going to cut off contact with every single person i know and emerge in a few months o a year from now having lost the ability to physically speak but be able to play the meanest fucking accordion youve ever heard in your pathetic little life	I don't know
What emojis (if any) would you add to this tweet?	im going to cut off contact with every single person i know and emerge in a few months o a year from now having lost the ability to physically speak but be able to play the meanest fucking accordion youve ever heard in your pathetic little life 😊
Its funny that you guys thought sports mattered during a pandemic. I simply can not imagine caring about a winning streak rn.	It is sarcastic
What emojis (if any) would you add to this tweet?	Its funny that you guys thought sports mattered during a pandemic. I simply can not imagine caring about a winning streak rn.
why was suite life on deck not called zack and cody on a boaty??? missed opportunity	It is not sarcastic
What emojis (if any) would you add to this tweet?	why was suite life on deck not called zack and cody on a boaty??? missed opportunity 😞
excited to start my new hobby of standing in the lgbtq section of the feminist bookstore and look hot and mysterious until I get noticed	It is not sarcastic
What emojis (if any) would you add to this tweet?	excited to start my new hobby of standing in the lgbtq section of the feminist bookstore and look hot and mysterious until I get noticed 😊

ah yes, of the course the summer rain pours when im on foot.	It is not sarcastic
What emojis (if any) would you add to this tweet?	ah yes, of the course the summer rain pours when im on foot. 😊
The fair-weather fans in all of these threads. Wake up call. Fleury is a human being. Surprise!	I don't know
What emojis (if any) would you add to this tweet?	The fair-weather fans in all of these threads. Wake up call. Fleury is a human being. Surprise!
Do you have any comments you would like to make?	

Participant Number	67
Question	Response
Qualification questions	
Consent to participate.	Yes
Are you over 18?	Yes
Do you use emojis?	Yes
Demographic Questions	
What is your gender?	Male
What age are you?	35-44
What is sarcasm?	Ironic humour
Emoji Usage Questions	
@traves whoa! that's a little too crazy man, slow down	I don't know
What emojis (if any) would you add to this tweet?	@traves whoa! that's a little too crazy man, slow down
Pub crawl pub crawl pub crawl pub crawl pub crawl. There are pubs and I am crawling too them	I don't know
What emojis (if any) would you add to this tweet?	Pub crawl pub crawl pub crawl pub crawl pub crawl. There are pubs and I am crawling too them

I want one of those ninja insects. You know the guys	It is not sarcastic
What emojis (if any) would you add to this tweet?	I want one of those ninja insects. You know the guys
Wow. Liam Neeson is coming across as a rational man, isn't he!!?	It is sarcastic
What emojis (if any) would you add to this tweet?	Wow. Liam Neeson is coming across as a rational man, isn't he!!? 😏
No joke, air-fried Twisted Teas are THE BEST.	I don't know
What emojis (if any) would you add to this tweet?	No joke, air-fried Twisted Teas are THE BEST.
why is someone jackhammering at 8am omfg	It is not sarcastic
What emojis (if any) would you add to this tweet?	why is someone jackhammering at 8am omfg 😭
I want a bloomin onion	I don't know
What emojis (if any) would you add to this tweet?	I want a bloomin onion
"I find it hilarious that black and white or all or nothing thinking is considered a cognitive distortion and is a symptom of several disorders, and yet it remains a pillar of American (and Western) culture. Its almost like. our culture is toxic	It is sarcastic
What emojis (if any) would you add to this tweet?	"I find it hilarious that black and white or all or nothing thinking is considered a cognitive distortion and is a symptom of several disorders, and yet it remains a pillar of American (and Western) culture. Its almost like. our culture is toxic 🙄
Do you have any comments you would like to make?	

Participant Number	68
Question	Response
Qualification questions	
Consent to participate.	Yes

Are you over 18?	Yes
Do you use emojis?	Yes
Demographic Questions	
What is your gender?	Female
What age are you?	35-44
What is sarcasm?	Jokes used to criticise someone
Emoji Usage Questions	
dont you love it when youre just chilling in your room and then theres a spider and you kill it but when you kill it you spill soda all over your keyboard yeah me too	It is sarcastic
What emojis (if any) would you add to this tweet?	dont you love it when youre just chilling in your room and then theres a spider 🐜 and you kill it but when you kill it you spill soda all over your keyboard 😞 yeah me too 🙄
Thanks @Tesco for not informing me that my click and collect order had been cancelled when my account says it's ready to collect my partner has had to travel unnecessarily to Stafford and we still don't have our shopping, good diet I guess having to wait for my 26th delivery slot https://t.co/xq9oXEkw8o	It is sarcastic
What emojis (if any) would you add to this tweet?	Thanks @Tesco for not informing me that my click and collect order had been cancelled 🙄 when my account says it's ready to collect my partner has had to travel unnecessarily to Stafford and we still don't have our shopping, good diet I guess having to wait for my 26th delivery slot 🙄🙄 https://t.co/xq9oXEkw8o
My dream is to be left alone.	It is not sarcastic
What emojis (if any) would you add to this tweet?	My dream is to be left alone. 😊😊
@HarryrotterDB Yeah I'll probs try it out too.	It is not sarcastic
What emojis (if any) would you add to this tweet?	@HarryrotterDB Yeah I'll probs try it out too.
@DarkenerWoW @wochinimen @MissPurplePixie shit healer	It is sarcastic
What emojis (if any) would you add to this tweet?	@DarkenerWoW @wochinimen @MissPurplePixie shit healer 😞🐜

@lora SHOCKED. How am I supposed to tell the kids they're not going to Disneyland on June 21st after all? It's already been cancelled 36 times! https://t.co/SV8gpPn6yw	I don't know
What emojis (if any) would you add to this tweet?	@lora SHOCKED. How am I supposed to tell the kids they're not going to Disneyland on June 21st after all? It's already been cancelled 36 times! 🙄 https://t.co/SV8gpPn6yw
@BorisJohnson @MattHancock Oh really?	I don't know
What emojis (if any) would you add to this tweet?	@BorisJohnson @MattHancock Oh really?
@futboljacob @LFC @Thiago6 It literally says in the article that hes expected back next week.	It is not sarcastic
What emojis (if any) would you add to this tweet?	@futboljacob @LFC @Thiago6 It literally says in the article that hes expected back next week. 🙄
Living with a str*ight man is like living with a four year old	It is not sarcastic
What emojis (if any) would you add to this tweet?	Living with a str*ight man is like living with a four year old 😏
love when the train stops in philly and everybody boards and of a sudden it smells like a ham sandwich	It is sarcastic
What emojis (if any) would you add to this tweet?	love when the train stops in philly and everybody boards and of a sudden it smells like a ham sandwich 🙄
Do you have any comments you would like to make?	na

Participant Number	69
Question	Response
Qualification questions	
Consent to participate.	Yes
Are you over 18?	Yes
Do you use emojis?	Yes
Demographic Questions	

What is your gender?	Male
What age are you?	18-24
What is sarcasm?	The lowest form of humour
Emoji Usage Questions	
dont you love it when youre just chilling in your room and then theres a spider and you kill it but when you kill it you spill soda all over your keyboard yeah me too	It is not sarcastic
What emojis (if any) would you add to this tweet?	dont you love it when youre just chilling in your room and then theres a spider and you kill it but when you kill it you spill soda all over your keyboard yeah me too 😭
@kidcuisine98 Based confidence and believing in proper eye contact-pilled!	I don't know
What emojis (if any) would you add to this tweet?	@kidcuisine98 Based confidence and believing in proper eye contact-pilled!
Replace Pelosi #Nancy	I don't know
What emojis (if any) would you add to this tweet?	Replace Pelosi #Nancy
@suzysophia_ SO PROUD OF YOU	It is not sarcastic
What emojis (if any) would you add to this tweet?	@suzysophia_ SO PROUD OF YOU 😁
crocheting is hard	It is sarcastic
What emojis (if any) would you add to this tweet?	crocheting is hard
@SrutisJay one of them smonks weed so it's super worth it /s	It is not sarcastic
What emojis (if any) would you add to this tweet?	@SrutisJay one of them smonks weed so it's super worth it /s
@Dancruz07 Sureeeeeeee you do	It is sarcastic
What emojis (if any) would you add to this tweet?	@Dancruz07 Sureeeeeeee you do 😊

the curious george soundtrack radicalized me at the tender age of four	It is sarcastic
What emojis (if any) would you add to this tweet?	the curious george soundtrack radicalized me at the tender age of four 🙈
rom coms from the 2000s are simply built different	It is sarcastic
What emojis (if any) would you add to this tweet?	rom coms from the 2000s are simply built different
Bart is closed rn in Oakland so I cant go to work, Im so upset....	It is sarcastic
What emojis (if any) would you add to this tweet?	Bart is closed rn in Oakland so I cant go to work, Im so upset....
Do you have any comments you would like to make?	

Participant Number	70
Question	Response
Qualification questions	
Consent to participate.	Yes
Are you over 18?	Yes
Do you use emojis?	Yes
Demographic Questions	
What is your gender?	Female
What age are you?	25-34
What is sarcasm?	Using humour to soften the blow when saying something insulting
Emoji Usage Questions	
dont you love it when youre just chilling in your room and then theres a spider and you kill it but when you kill it you spill soda all over your keyboard yeah me too	It is sarcastic

What emojis (if any) would you add to this tweet?	dont you love it when youre just chilling in your room and then theres a spider and you kill it but when you kill it you spill soda all over your keyboard yeah me too 😊
first game not starting when it's supposed to? a UCF tradition	It is sarcastic
What emojis (if any) would you add to this tweet?	first game not starting when it's supposed to? a UCF tradition 😞
im about to just walk into a place and start working then and there and they'll have no choice but to hire me on the spot	It is sarcastic
What emojis (if any) would you add to this tweet?	im about to just walk into a place and start working then and there and they'll have no choice but to hire me on the spot 😊
Beautiful animation and hype song what more could be asked for https://t.co/PFLlswgkh3	It is not sarcastic
What emojis (if any) would you add to this tweet?	Beautiful animation and hype song what more could be asked for https://t.co/PFLlswgkh3 😊
APPLE CIDER IS BACK AT DUNKS BABY	It is not sarcastic
What emojis (if any) would you add to this tweet?	APPLE CIDER IS BACK AT DUNKS BABY 😞
just stuck my entire hand in a hot oven without thinking about the consequences. self preservation is clearly my strong suit	It is sarcastic
What emojis (if any) would you add to this tweet?	just stuck my entire hand in a hot oven without thinking about the consequences. self preservation is clearly my strong suit 😊
Turnover is the best band to cry to/drive to/daydream to/fall asleep to/ reminisce to/die to	It is not sarcastic
What emojis (if any) would you add to this tweet?	Turnover is the best band to cry to/drive to/daydream to/fall asleep to/ reminisce to/die to 😞
i cant wait to leave boston	It is not sarcastic
What emojis (if any) would you add to this tweet?	i cant wait to leave boston 😞

this is the first time in 6 years i havent had to move, i am so relieved	It is not sarcastic
What emojis (if any) would you add to this tweet?	this is the first time in 6 years i havent had to move, i am so relieved 😊
Congratulations to Trump on his second impeachment. Its a tremendous achievement borne of hard work, focus and dedication. Record breaking. Historic. Bigly. #ImpeachmentDay #TrumpImpeachment2	It is not sarcastic
What emojis (if any) would you add to this tweet?	Congratulations to Trump on his second impeachment. Its a tremendous achievement borne of hard work, focus and dedication. Record breaking. Historic. Bigly. #ImpeachmentDay #TrumpImpeachment2 👍
Do you have any comments you would like to make?	

Participant Number	71
Question	Response
Qualification questions	
Consent to participate.	Yes
Are you over 18?	Yes
Do you use emojis?	Yes
Demographic Questions	
What is your gender?	Male
What age are you?	18-24
What is sarcasm?	Saying the opposite of what you mean when the thing you want to say will come across badly
Emoji Usage Questions	
dont you love it when you're just chilling in your room and then there's a spider and you kill it but when you kill it you spill soda all over your keyboard yeah me too	It is sarcastic
What emojis (if any) would you add to this tweet?	😁 dont you love it when you're just chilling in your room and then there's a spider and you kill it but when you kill it you spill soda all over your keyboard yeah me too 👍
Keanu reeves is killing his role in ozark season 3	It is not sarcastic
What emojis (if any) would you add to this tweet?	Keanu reeves is killing his role in ozark season 3 😊

getting stopped by tesco security is the highlight of my day	It is sarcastic
What emojis (if any) would you add to this tweet?	getting stopped by tesco security is the highlight of my day👍
My tolerance for heat is near zero. Sweating putting washing out	It is not sarcastic
What emojis (if any) would you add to this tweet?	My tolerance for heat is near zero. Sweating putting washing out
Just had my windows cleaned and I feel posh lmao	It is not sarcastic
What emojis (if any) would you add to this tweet?	Just had my windows cleaned and I feel posh lmao😂
Yay for being locked out of your own house because you forgot your key	It is sarcastic
What emojis (if any) would you add to this tweet?	Yay for being locked out of your own house because you forgot your key😏
craving an ice pick lobotomy on this Friday afternoon	I don't know
What emojis (if any) would you add to this tweet?	craving an ice pick lobotomy on this Friday afternoon
I hate how anti vaxxers have ruined everything. Trying to find information on vaccine side effects and it's plagued with morons	It is not sarcastic
What emojis (if any) would you add to this tweet?	I hate how anti vaxxers have ruined everything. Trying to find information on vaccine side effects and it's plagued with morons😡
I forgot to kip	I don't know
What emojis (if any) would you add to this tweet?	I forgot to kip

My coworkers play this fun game where they try to describe bars in la crosse & have me guess which one theyre talking about	I don't know
What emojis (if any) would you add to this tweet?	My coworkers play this fun game where they try to describe bars in la crosse & have me guess which one theyre talking about 😊
Do you have any comments you would like to make?	last 3 tweets or so I didn't even know what they meant

Participant Number	72
Question	Response
Qualification questions	
Consent to participate.	Yes
Are you over 18?	Yes
Do you use emojis?	Yes
Demographic Questions	
What is your gender?	Female
What age are you?	18-24
What is sarcasm?	Implying something using words that mean the opposite
Emoji Usage Questions	
dont you love it when youre just chilling in your room and then theres a spider and you kill it but when you kill it you spill soda all over your keyboard yeah me too	It is sarcastic
What emojis (if any) would you add to this tweet?	😂 dont you love it when youre just chilling in your room and then theres a spider and you kill it but when you kill it you spill soda all over your keyboard yeah me too
Keanu reeves is killing his role in ozark season 3	It is sarcastic
What emojis (if any) would you add to this tweet?	Keanu reeves is killing his role in ozark season 3 😂
getting stopped by tesco security is the highlight of my day	It is not sarcastic

What emojis (if any) would you add to this tweet?	getting stopped by tesco security is the highlight of my day
My tolerance for heat is near zero. Sweating putting washing out	It is sarcastic
What emojis (if any) would you add to this tweet?	My tolerance for heat is near zero. Sweating putting washing out 😊
Just had my windows cleaned and I feel posh lmao	It is sarcastic
What emojis (if any) would you add to this tweet?	Just had my windows cleaned and I feel posh lmao 😂
Yay for being locked out of your own house because you forgot your key	It is sarcastic
What emojis (if any) would you add to this tweet?	Yay for being locked out of your own house because you forgot your key 🙄
craving an ice pick lobotomy on this Friday afternoon	I don't know
What emojis (if any) would you add to this tweet?	craving an ice pick lobotomy on this Friday afternoon
I hate how anti vaxxers have ruined everything. Trying to find information on vaccine side effects and it's plagued with morons	It is not sarcastic
What emojis (if any) would you add to this tweet?	I hate how anti vaxxers have ruined everything. Trying to find information on vaccine side effects and it's plagued with morons
I forgot to kip	I don't know
What emojis (if any) would you add to this tweet?	I forgot to kip
My coworkers play this fun game where they try to describe bars in la crosse & have me guess which one theyre talking about	I don't know

What emojis (if any) would you add to this tweet?	My coworkers play this fun game where they try to describe bars in la crosse & have me guess which one theyre talking about 🤔
Do you have any comments you would like to make?	

Participant Number	73
Question	Response
Qualification questions	
Consent to participate.	Yes
Are you over 18?	Yes
Do you use emojis?	Yes
Demographic Questions	
What is your gender?	Female
What age are you?	25-34
What is sarcasm?	your doing a study about it... I would hope you already know
Emoji Usage Questions	
dont you love it when youre just chilling in your room and then theres a spider and you kill it but when you kill it you spill soda all over your keyboard yeah me too	It is sarcastic
What emojis (if any) would you add to this tweet?	dont you love it when youre just chilling in your room and then theres a spider and you kill it but when you kill it you spill soda all over your keyboard yeah me too 🤔
Keanu reeves is killing his role in ozark season 3	I don't know
What emojis (if any) would you add to this tweet?	Keanu reeves is killing his role in ozark season 3 🤔
getting stopped by tesco security is the highlight of my day	I don't know
What emojis (if any) would you add to this tweet?	getting stopped by tesco security is the highlight of my day

My tolerance for heat is near zero. Sweating putting washing out	It is not sarcastic
What emojis (if any) would you add to this tweet?	My tolerance for heat is near zero. Sweating putting washing out 😡
Just had my windows cleaned and I feel posh lmao	It is sarcastic
What emojis (if any) would you add to this tweet?	Just had my windows cleaned and I feel posh lmao 😏
Yay for being locked out of your own house because you forgot your key	It is sarcastic
What emojis (if any) would you add to this tweet?	Yay for being locked out of your own house because you forgot your key 🙄
craving an ice pick lobotomy on this Friday afternoon	It is sarcastic
What emojis (if any) would you add to this tweet?	craving an ice pick lobotomy on this Friday afternoon 🤪
I hate how anti vaxxers have ruined everything. Trying to find information on vaccine side effects and it's plagued with morons	It is not sarcastic
What emojis (if any) would you add to this tweet?	I hate how anti vaxxers have ruined everything. Trying to find information on vaccine side effects and it's plagued with morons 😡
I forgot to kip	It is sarcastic
What emojis (if any) would you add to this tweet?	I forgot to kip
My coworkers play this fun game where they try to describe bars in la crosse & have me guess which one theyre talking about	It is sarcastic
What emojis (if any) would you add to this tweet?	My coworkers play this fun game where they try to describe bars in la crosse & have me guess which one theyre talking about
Do you have any comments you would like to make?	

Participant Number	74
---------------------------	-----------

Question	Response
Qualification questions	
Consent to participate.	Yes
Are you over 18?	Yes
Do you use emojis?	Yes
Demographic Questions	
What is your gender?	Male
What age are you?	25-34
What is sarcasm?	Insults framed as positive comments
Emoji Usage Questions	
dont you love it when youre just chilling in your room and then theres a spider and you kill it but when you kill it you spill soda all over your keyboard yeah me too	It is sarcastic
What emojis (if any) would you add to this tweet?	😏 dont you love it when youre just chilling in your room and then theres a spider and you kill it but when you kill it you spill soda all over your keyboard yeah me too 😏
Keanu reeves is killing his role in ozark season 3	It is not sarcastic
What emojis (if any) would you add to this tweet?	Keanu reeves is killing his role in ozark season 3 🙄
getting stopped by tesco security is the highlight of my day	It is sarcastic
What emojis (if any) would you add to this tweet?	getting stopped by tesco security is the highlight of my day 😏
My tolerance for heat is near zero. Sweating putting washing out	It is not sarcastic
What emojis (if any) would you add to this tweet?	My tolerance for heat is near zero. Sweating putting washing out 😏
Just had my windows cleaned and I feel posh lmao	It is sarcastic
What emojis (if any) would you add to this tweet?	Just had my windows cleaned and I feel posh lmao 😏
Yay for being locked out of your own house because you forgot your key	It is sarcastic

What emojis (if any) would you add to this tweet?	Yay for being locked out of your own house because you forgot your key 😊
craving an ice pick lobotomy on this Friday afternoon	It is sarcastic
What emojis (if any) would you add to this tweet?	craving an ice pick lobotomy on this Friday afternoon 😊
I hate how anti vaxxers have ruined everything. Trying to find information on vaccine side effects and it's plagued with morons	It is sarcastic
What emojis (if any) would you add to this tweet?	I hate how anti vaxxers have ruined everything. Trying to find information on vaccine side effects and it's plagued with morons 😊
I forgot to kip	I don't know
What emojis (if any) would you add to this tweet?	I forgot to kip 😊
My coworkers play this fun game where they try to describe bars in la crosse & have me guess which one theyre talking about	I don't know
What emojis (if any) would you add to this tweet?	My coworkers play this fun game where they try to describe bars in la crosse & have me guess which one theyre talking about 😊
Do you have any comments you would like to make?	

Participant Number	75
Question	Response
Qualification questions	
Consent to participate.	Yes
Are you over 18?	Yes
Do you use emojis?	Yes
Demographic Questions	
What is your gender?	Male
What age are you?	35-44
What is sarcasm?	When the way you say something means you really mean the opposite of the meaning of the words

Emoji Usage Questions	
@kidcuisine98 Based confidence and believing in proper eye contact-pilled!	I don't know
What emojis (if any) would you add to this tweet?	@kidcuisine98 Based confidence and believing in proper eye contact-pilled! 😡
Replace Pelosi #Nancy	I don't know
What emojis (if any) would you add to this tweet?	Replace Pelosi #Nancy 😞
@suzysophia_ SO PROUD OF YOU	It is not sarcastic
What emojis (if any) would you add to this tweet?	@suzysophia_ SO PROUD OF YOU 😊
crocheting is hard	It is not sarcastic
What emojis (if any) would you add to this tweet?	crocheting is hard 😞
@SrutisJay one of them smonks weed so it's super worth it /s	It is sarcastic
What emojis (if any) would you add to this tweet?	@SrutisJay one of them smonks weed so it's super worth it /s 😊
@Dancruz07 Sureeeeeeee you do	It is sarcastic
What emojis (if any) would you add to this tweet?	@Dancruz07 Sureeeeeeee you do 😂 😊
the curious george soundtrack radicalized me at the tender age of four	It is sarcastic
What emojis (if any) would you add to this tweet?	the curious george soundtrack radicalized me at the tender age of four 😊

rom coms from the 2000s are simply built different	I don't know
What emojis (if any) would you add to this tweet?	rom coms from the 2000s are simply built different 🙄
Bart is closed rn in Oakland so I cant go to work, Im so upset....	I don't know
What emojis (if any) would you add to this tweet?	Bart is closed rn in Oakland so I cant go to work, Im so upset.... 🙄
first game not starting when it's supposed to? a UCF tradition	It is sarcastic
What emojis (if any) would you add to this tweet?	first game not starting when it's supposed to? a UCF tradition 😏
Do you have any comments you would like to make?	No

Participant Number	76
Question	Response
Qualification questions	
Consent to participate.	Yes
Are you over 18?	Yes
Do you use emojis?	Yes
Demographic Questions	
What is your gender?	Female
What age are you?	45-64
What is sarcasm?	Saying the opposite of what you mean
Emoji Usage Questions	
im about to just walk into a place and start working then and there and they'll have no choice but to hire me on the spot	It is sarcastic
What emojis (if any) would you add to this tweet?	im about to just walk into a place and start working then and there and they'll have no choice but to hire me on the spot 😏

Beautiful animation and hype song what more could be asked for https://t.co/PFLlswgkh3	It is sarcastic
What emojis (if any) would you add to this tweet?	Beautiful animation and hype song what more could be asked for https://t.co/PFLlswgkh3 😊
APPLE CIDER IS BACK AT DUNKS BABY	It is sarcastic
What emojis (if any) would you add to this tweet?	APPLE CIDER IS BACK AT DUNKS BABY 🤔
just stuck my entire hand in a hot oven without thinking about the consequences. self preservation is clearly my strong suit	It is sarcastic
What emojis (if any) would you add to this tweet?	just stuck my entire hand in a hot oven without thinking about the consequences. self preservation is clearly my strong suit 😊
Turnover is the best band to cry to/drive to/daydream to/fall asleep to/ reminisce to/die to	I don't know
What emojis (if any) would you add to this tweet?	Turnover is the best band to cry to/drive to/daydream to/fall asleep to/ reminisce to/die to 😊
i cant wait to leave boston	It is not sarcastic
What emojis (if any) would you add to this tweet?	i cant wait to leave boston ❤️
this is the first time in 6 years i havent had to move, i am so relieved	It is not sarcastic
What emojis (if any) would you add to this tweet?	this is the first time in 6 years i havent had to move, i am so relieved 😊
Congratulations to Trump on his second impeachment. Its a tremendous achievement borne of hard work, focus and dedication. Record breaking. Historic. Bigly. #ImpeachmentDay #TrumpImpeachment2	It is not sarcastic
What emojis (if any) would you add to this tweet?	Congratulations to Trump on his second impeachment. Its a tremendous achievement borne of hard work, focus and dedication. Record breaking. Historic. Bigly. #ImpeachmentDay #TrumpImpeachment2 😊

Do you have any comments you would like to make?	
--	--

Participant Number	77
Question	Response
Qualification questions	
Consent to participate.	Yes
Are you over 18?	Yes
Do you use emojis?	Yes
Demographic Questions	
What is your gender?	Male
What age are you?	18-24
What is sarcasm?	saying one thing but meaning something else kinda to be mean without being mean?
Emoji Usage Questions	
dont you love it when youre just chilling in your room and then theres a spider and you kill it but when you kill it you spill soda all over your keyboard yeah me too 😞	It is sarcastic
What emojis (if any) would you add to this tweet?	dont you love it when youre just chilling in your room and then theres a spider and you kill it but when you kill it you spill soda all over your keyboard yeah me too 😞
Keanu reeves is killing his role in ozark season 3	I don't know
What emojis (if any) would you add to this tweet?	Keanu reeves is killing his role in ozark season 3
getting stopped by tesco security is the highlight of my day	It is not sarcastic
What emojis (if any) would you add to this tweet?	getting stopped by tesco security is the highlight of my day 😞
My tolerance for heat is near zero. Sweating putting washing out	I don't know
What emojis (if any) would you add to this tweet?	My tolerance for heat is near zero. Sweating putting washing out
Just had my windows cleaned and I feel posh lmao	I don't know

What emojis (if any) would you add to this tweet?	Just had my windows cleaned and I feel posh lmao 😏
Yay for being locked out of your own house because you forgot your key	It is not sarcastic
What emojis (if any) would you add to this tweet?	Yay for being locked out of your own house because you forgot your key 😏
craving an ice pick lobotomy on this Friday afternoon	It is sarcastic
What emojis (if any) would you add to this tweet?	craving an ice pick lobotomy on this Friday afternoon 😏
I hate how anti vaxxers have ruined everything. Trying to find information on vaccine side effects and it's plagued with morons	It is not sarcastic
What emojis (if any) would you add to this tweet?	I hate how anti vaxxers have ruined everything. Trying to find information on vaccine side effects and it's plagued with morons
I forgot to kip	I don't know
What emojis (if any) would you add to this tweet?	I forgot to kip
My coworkers play this fun game where they try to describe bars in la crosse & have me guess which one theyre talking about	It is not sarcastic
What emojis (if any) would you add to this tweet?	My coworkers play this fun game where they try to describe bars in la crosse & have me guess which one theyre talking about
Do you have any comments you would like to make?	Tone in writing is easily misinterpreted

Participant Number	78
Question	Response
Qualification questions	
Consent to participate.	Yes
Are you over 18?	Yes
Do you use emojis?	Yes
Demographic Questions	

What is your gender?	Male
What age are you?	18-24
What is sarcasm?	A way to get away with saying something insulting by making it sound nice
Emoji Usage Questions	
@kidcuisine98 Based confidence and believing in proper eye contact-pilled!	It is sarcastic
What emojis (if any) would you add to this tweet?	@kidcuisine98 Based confidence and believing in proper eye contact-pilled! 🙄
Replace Pelosi #Nancy	It is not sarcastic
What emojis (if any) would you add to this tweet?	Replace Pelosi #Nancy
@suzysophia_ SO PROUD OF YOU	It is not sarcastic
What emojis (if any) would you add to this tweet?	@suzysophia_ SO PROUD OF YOU 🙄
crocheting is hard	It is not sarcastic
What emojis (if any) would you add to this tweet?	crocheting is hard
@SrutisJay one of them smonks weed so it's super worth it /s	It is not sarcastic
What emojis (if any) would you add to this tweet?	@SrutisJay one of them smonks weed so it's super worth it /s
@Dancruz07 Sureeeeeeee you do	It is sarcastic
What emojis (if any) would you add to this tweet?	@Dancruz07 Sureeeeeeee you do 😏
the curious george soundtrack radicalized me at the tender age of four	It is sarcastic
What emojis (if any) would you add to this tweet?	the curious george soundtrack radicalized me at the tender age of four 🙄

rom coms from the 2000s are simply built different	It is not sarcastic
What emojis (if any) would you add to this tweet?	rom coms from the 2000s are simply built different
Bart is closed rn in Oakland so I cant go to work, Im so upset....	It is sarcastic
What emojis (if any) would you add to this tweet?	Bart is closed rn in Oakland so I cant go to work, Im so upset.... 😊
first game not starting when it's supposed to? a UCF tradition	It is sarcastic
What emojis (if any) would you add to this tweet?	first game not starting when it's supposed to? a UCF tradition 🙄
Do you have any comments you would like to make?	Lame

Participant Number	79
Question	Response
Qualification questions	
Consent to participate.	Yes
Are you over 18?	Yes
Do you use emojis?	Yes
Demographic Questions	
What is your gender?	Male
What age are you?	25-34
What is sarcasm?	Blunt statements which are often intended to poke fun at someone but the literal meaning of the words doesn't make the intent clear
Emoji Usage Questions	
im about to just walk into a place and start working then and there and they'll have no choice but to hire me on the spot	I don't know

What emojis (if any) would you add to this tweet?	im about to just walk into a place and start working then and there and they'll have no choice but to hire me on the spot
Beautiful animation and hype song what more could be asked for https://t.co/PFLlswgkh3	It is not sarcastic
What emojis (if any) would you add to this tweet?	Beautiful animation and hype song what more could be asked for https://t.co/PFLlswgkh3
APPLE CIDER IS BACK AT DUNKS BABY	I don't know
What emojis (if any) would you add to this tweet?	APPLE CIDER IS BACK AT DUNKS BABY
just stuck my entire hand in a hot oven without thinking about the consequences. self preservation is clearly my strong suit	It is sarcastic
What emojis (if any) would you add to this tweet?	just stuck my entire hand in a hot oven without thinking about the consequences. self preservation is clearly my strong suit
Turnover is the best band to cry to/drive to/daydream to/fall asleep to/ reminisce to/die to	It is sarcastic
What emojis (if any) would you add to this tweet?	Turnover is the best band to cry to/drive to/daydream to/fall asleep to/ reminisce to/die to 😊
i cant wait to leave boston	It is not sarcastic
What emojis (if any) would you add to this tweet?	i cant wait to leave boston
this is the first time in 6 years i havent had to move, i am so relieved	It is not sarcastic
What emojis (if any) would you add to this tweet?	this is the first time in 6 years i havent had to move, i am so relieved
Congratulations to Trump on his second impeachment. Its a tremendous achievement borne of hard work, focus and dedication. Record breaking. Historic. Bigly. #ImpeachmentDay #TrumpImpeachment2	It is sarcastic



What emojis (if any) would you add to this tweet?	Congratulations to Trump on his second impeachment. Its a tremendous achievement borne of hard work, focus and dedication. Record breaking. Historic. Bigly. #ImpeachmentDay #TrumpImpeachment2 😂
Do you have any comments you would like to make?	I dont understand language anymore

Participant Number	80
Question	Response
Qualification questions	
Consent to participate.	Yes
Are you over 18?	Yes
Do you use emojis?	Yes
Demographic Questions	
What is your gender?	Female
What age are you?	35-44
What is sarcasm?	When you say something in such a way that the tone implies that you mean the opposite
Emoji Usage Questions	
was not aware that Crocs were appropriate business casual attire.	It is sarcastic
What emojis (if any) would you add to this tweet?	was not aware that Crocs were appropriate business casual attire. 😞
it's too bad i forgot how to play my clarinet so close to my recital	It is not sarcastic
What emojis (if any) would you add to this tweet?	it's too bad i forgot how to play my clarinet so close to my recital 😭
"but clinton's emails! oh. emm. fucking. gee. clinton's god damnd emails. the humanity of it all. https://t.co/cibY5Tn9s6 "	It is not sarcastic
What emojis (if any) would you add to this tweet?	"but clinton's emails! oh. emm. fucking. gee. clinton's god damnd emails. the humanity of it all. https://t.co/cibY5Tn9s6 " 😬
going to class! https://t.co/VgCWGI9YTG	It is not sarcastic
What emojis (if any) would you add to this tweet?	going to class! https://t.co/VgCWGI9YTG 😁

can some1 do my geometry hw	It is not sarcastic
What emojis (if any) would you add to this tweet?	can some1 do my geometry hw 🙊
@adorinqdwt @dwtridesgnf Yes the racist is so cool!!!	It is sarcastic
What emojis (if any) would you add to this tweet?	@adorinqdwt @dwtridesgnf Yes the racist is so cool!!! 😬
Putting the toilet paper roll on so that it hangs under instead of over is a crime worthy of the death penalty	It is sarcastic
What emojis (if any) would you add to this tweet?	Putting the toilet paper roll on so that it hangs under instead of over is a crime worthy of the death penalty 😬
Maxwell, Arthurs middle name is Grandpas name. So he has a piece of two very important people of Mikeys family. Grandpa is a incredible guy and this was probably the only thing at this point that we could give him to make him feel appreciated and loved. Grandpa loves his name.	It is not sarcastic
What emojis (if any) would you add to this tweet?	Maxwell, Arthurs middle name is Grandpas name. So he has a piece of two very important people of Mikeys family. Grandpa is a incredible guy and this was probably the only thing at this point that we could give him to make him feel appreciated and loved. Grandpa loves his name. 🙌
Trader Joe's Candy Cane Joe-Joes are pure crack and I cave to them every year.	It is not sarcastic
What emojis (if any) would you add to this tweet?	Trader Joe's Candy Cane Joe-Joes are pure crack and I cave to them every year. 🙌
"Synthwave communities really love pessimism don't they haha Any upbeat energy and people get upset at ya"	It is not sarcastic
What emojis (if any) would you add to this tweet?	"Synthwave communities really love pessimism don't they haha Any upbeat energy and people get upset at ya" 😂
Do you have any comments you would like to make?	

Participant Number	81
---------------------------	-----------

Question	Response
Qualification questions	
Consent to participate.	Yes
Are you over 18?	Yes
Do you use emojis?	Yes
Demographic Questions	
What is your gender?	Female
What age are you?	35-44
What is sarcasm?	Similar to irony where you say the opposite what you mean in a joking manner
Emoji Usage Questions	
was not aware that Crocs were appropriate business casual attire.	It is sarcastic
What emojis (if any) would you add to this tweet?	was not aware that Crocs were appropriate business casual attire. 😏
@avsmph But how can we possibly deal with a human experience we haven't first relentlessly quantified???	It is sarcastic
What emojis (if any) would you add to this tweet?	@avsmph But how can we possibly deal with a human experience we haven't first relentlessly quantified??? 🙄
The Drew Barrymore Show is an absolute trainwreck. Like The Tony Danza Show, every two minutes is a clip for The Soup.	It is sarcastic
What emojis (if any) would you add to this tweet?	The Drew Barrymore Show is an absolute trainwreck. Like The Tony Danza Show, every two minutes is a clip for The Soup. 😏
At the point in my life where my body keeps developing new allergies. My metabolism has slowed, hangovers are no joke anymore, and now I can't eat several of my favorite fruits. Screw wrinkles, this is the reason why people are afraid of getting old	It is not sarcastic
What emojis (if any) would you add to this tweet?	At the point in my life where my body keeps developing new allergies. My metabolism has slowed, hangovers are no joke anymore, and now I can't eat several of my favorite fruits. Screw wrinkles, this is the reason why people are afraid of getting old
Sitting on our new leather sofa, windows open, rain outside, candle burning, Sex and the City on, glass of rose in hand. This is it. This is a pure vibe.	It is not sarcastic

What emojis (if any) would you add to this tweet?	Sitting on our new leather sofa, windows open, rain outside, candle burning, Sex and the City on, glass of rose in hand. This is it. This is a pure vibe.
Turned 25 today but woke up with \$600 from the IRS in my bank account so quarter life crisis has been postponed	It is sarcastic
What emojis (if any) would you add to this tweet?	Turned 25 today but woke up with \$600 from the IRS in my bank account so quarter life crisis has been postponed 
Only a a President as strong and decisive as @realDonaldTrump would force the FDA to OK a drug even before clinical trial results are in. No need to wait for such silly formalities - people have been taking the drug for years and most are still alive and fine! #OkToTry #Gotrump https://t.co/IdxTJ7kucp	It is not sarcastic
What emojis (if any) would you add to this tweet?	Only a a President as strong and decisive as @realDonaldTrump would force the FDA to OK a drug even before clinical trial results are in. No need to wait for such silly formalities - people have been taking the drug for years and most are still alive and fine! #OkToTry #Gotrump https://t.co/IdxTJ7kucp
@HawleyMO Please DO YOUR JOB or resign. Enough is enough.	It is sarcastic
What emojis (if any) would you add to this tweet?	@HawleyMO Please DO YOUR JOB or resign. Enough is enough.
@rolandsmartin @nypost Damn! At my wedding we drank enough to make up for the no shows!	It is sarcastic
What emojis (if any) would you add to this tweet?	@rolandsmartin @nypost Damn! At my wedding we drank enough to make up for the no shows! 
I reverse imaged searched a selfie and it under visually similar images it is exclusively asian woman my am I white passing narrative is quaking	It is sarcastic
What emojis (if any) would you add to this tweet?	I reverse imaged searched a selfie and it under visually similar images it is exclusively asian woman my am I white passing narrative is quaking
Do you have any comments you would like to make?	

Participant Number	82
Question	Response
Qualification questions	
Consent to participate.	Yes
Are you over 18?	Yes
Do you use emojis?	Yes
Demographic Questions	
What is your gender?	Female
What age are you?	25-34
What is sarcasm?	statement which means the opposite of what the tone implies
Emoji Usage Questions	
was not aware that Crocs were appropriate business casual attire.	It is sarcastic
What emojis (if any) would you add to this tweet?	was not aware that Crocs were appropriate business casual attire. 😊
@Mythical So worried about him. But if you're looking to save him, based on the topography I'd say it's somewhere on the east coast. Perhaps the Carolinas?	It is not sarcastic
What emojis (if any) would you add to this tweet?	@Mythical So worried about him. But if you're looking to save him, based on the topography I'd say it's somewhere on the east coast. Perhaps the Carolinas?
It would be nice if my body would let me sleep...	It is sarcastic
What emojis (if any) would you add to this tweet?	It would be nice if my body would let me sleep... 😡
now that Im working in the commercial talent business, I cant help but wonder how much Jake from State Farm gets paid. I think about it every time I see a SF commercial	It is not sarcastic
What emojis (if any) would you add to this tweet?	now that Im working in the commercial talent business, I cant help but wonder how much Jake from State Farm gets paid. I think about it every time I see a SF commercial 😊
Poor Steve Clifford. Next hire has to be right to get us from A to B. #Magic	I don't know

What emojis (if any) would you add to this tweet?	Poor Steve Clifford. Next hire has to be right to get us from A to B. #Magic 😊
All the shade i have been hearing about Ben Platt being unbelievable as a teenager in the @DearEvanHansen movie boggles me. Does nobody have any memories of Grease??? Name 1 actor on that film who believably looked high school age!	It is sarcastic
What emojis (if any) would you add to this tweet?	All the shade i have been hearing about Ben Platt being unbelievable as a teenager in the @DearEvanHansen movie boggles me. Does nobody have any memories of Grease??? Name 1 actor on that film who believably looked high school age! 😞
the manliest thing I can think of is when the men from the World Cup passionately sing their national anthem	It is sarcastic
What emojis (if any) would you add to this tweet?	the manliest thing I can think of is when the men from the World Cup passionately sing their national anthem 😊
Making the leap from TopShot...officially purchased my @HouseofKibaa membership this morning. Very excited! Thank you @kibaa_hok and team -- very easy process.	It is not sarcastic
What emojis (if any) would you add to this tweet?	Making the leap from TopShot...officially purchased my @HouseofKibaa membership this morning. Very excited! Thank you @kibaa_hok and team -- very easy process.
Also, hopefully and presumably, the Magic front office continuing to do right by players. Give an opportunity - develop - let them go to a better situation. That's the way to do it.	It is sarcastic
What emojis (if any) would you add to this tweet?	Also, hopefully and presumably, the Magic front office continuing to do right by players. Give an opportunity - develop - let them go to a better situation. That's the way to do it.
If your website still has a google plus share button, forgive me if Im not tripping over myself to take your information as credible or current.	It is sarcastic
What emojis (if any) would you add to this tweet?	If your website still has a google plus share button, forgive me if Im not tripping over myself to take your information as credible or current. 🙄
Do you have any comments you would like to make?	Hard to analyse tweets out of context

Participant Number	83
Question	Response
Qualification questions	
Consent to participate.	Yes
Are you over 18?	Yes
Do you use emojis?	Yes
Demographic Questions	
What is your gender?	Female
What age are you?	45-64
What is sarcasm?	Implied meaning that indicates the message is not what the words literally mean (funny)
Emoji Usage Questions	
was not aware that Crocs were appropriate business casual attire.	It is sarcastic
What emojis (if any) would you add to this tweet?	was not aware that Crocs were appropriate business casual attire. 😬
@Mythical So worried about him. But if you're looking to save him, based on the topography I'd say it's somewhere on the east coast. Perhaps the Carolinas?	It is not sarcastic
What emojis (if any) would you add to this tweet?	@Mythical So worried about him. But if you're looking to save him, based on the topography I'd say it's somewhere on the east coast. Perhaps the Carolinas? 🙌
It would be nice if my body would let me sleep...	It is not sarcastic
What emojis (if any) would you add to this tweet?	It would be nice if my body would let me sleep... 😞😓
now that Im working in the commercial talent business, I cant help but wonder how much Jake from State Farm gets paid. I think about it every time I see a SF commercial	It is not sarcastic
What emojis (if any) would you add to this tweet?	now that Im working in the commercial talent business, I cant help but wonder how much Jake from State Farm gets paid. I think about it every time I see a SF commercial 😬
Poor Steve Clifford. Next hire has to be right to get us from A to B. #Magic	I don't know

What emojis (if any) would you add to this tweet?	Poor Steve Clifford. Next hire has to be right to get us from A to B. #Magic
All the shade i have been hearing about Ben Platt being unbelievable as a teenager in the @DearEvanHansen movie boggles me. Does nobody have any memories of Grease??? Name 1 actor on that film who believably looked high school age!	It is not sarcastic
What emojis (if any) would you add to this tweet?	All the shade i have been hearing about Ben Platt being unbelievable as a teenager in the @DearEvanHansen movie boggles me. Does nobody have any memories of Grease??? Name 1 actor on that film who believably looked high school age!
the manliest thing I can think of is when the men from the World Cup passionately sing their national anthem	I don't know
What emojis (if any) would you add to this tweet?	the manliest thing I can think of is when the men from the World Cup passionately sing their national anthem
Making the leap from TopShot...officially purchased my @HouseofKibaa membership this morning. Very excited! Thank you @kibaa_hok and team -- very easy process.	It is not sarcastic
What emojis (if any) would you add to this tweet?	Making the leap from TopShot...officially purchased my @HouseofKibaa membership this morning. Very excited! Thank you @kibaa_hok and team -- very easy process. 
Also, hopefully and presumably, the Magic front office continuing to do right by players. Give an opportunity - develop - let them go to a better situation. That's the way to do it.	It is not sarcastic
What emojis (if any) would you add to this tweet?	Also, hopefully and presumably, the Magic front office continuing to do right by players. Give an opportunity - develop - let them go to a better situation. That's the way to do it.
If your website still has a google plus share button, forgive me if Im not tripping over myself to take your information as credible or current.	It is sarcastic
What emojis (if any) would you add to this tweet?	If your website still has a google plus share button, forgive me if Im not tripping over myself to take your information as credible or current.
Do you have any comments you would like to make?	

Participant Number	84
Question	Response
Qualification questions	
Consent to participate.	Yes
Are you over 18?	Yes
Do you use emojis?	Yes
Demographic Questions	
What is your gender?	Male
What age are you?	45-64
What is sarcasm?	A way to exaggerate, change the meaning or intent of what you say generally using humour
Emoji Usage Questions	
it's too bad i forgot how to play my clarinet so close to my recital	It is sarcastic
What emojis (if any) would you add to this tweet?	it's too bad i forgot how to play my clarinet so close to my recital 🙄
"but clinton's emails! oh. emm. fucking. gee. clinton's god damnd emails. the humanity of it all. https://t.co/cibY5Tn9s6 "	It is sarcastic
What emojis (if any) would you add to this tweet?	"but clinton's emails! oh. emm. fucking. gee. clinton's god damnd emails. the humanity of it all. https://t.co/cibY5Tn9s6 " 🙄
going to class! https://t.co/VgCWGI9YTG	I don't know
What emojis (if any) would you add to this tweet?	going to class! https://t.co/VgCWGI9YTG
can some1 do my geometry hw	It is not sarcastic
What emojis (if any) would you add to this tweet?	can some1 do my geometry hw
@adorinqdwt @dwtridesgnf Yes the racist is so cool!!!	It is sarcastic
What emojis (if any) would you add to this tweet?	@adorinqdwt @dwtridesgnf Yes the racist is so cool!!! 😏
Putting the toilet paper roll on so that it hangs under instead of over is a crime worthy of the death penalty	It is sarcastic

What emojis (if any) would you add to this tweet?	Putting the toilet paper roll on so that it hangs under instead of over is a crime worthy of the death penalty 🗉😞
Maxwell, Arthurs middle name is Grandpas name. So he has a piece of two very important people of Mikeys family. Grandpa is a incredible guy and this was probably the only thing at this point that we could give him to make him feel appreciated and loved. Grandpa loves his name.	It is not sarcastic
What emojis (if any) would you add to this tweet?	Maxwell, Arthurs middle name is Grandpas name. So he has a piece of two very important people of Mikeys family. Grandpa is a incredible guy and this was probably the only thing at this point that we could give him to make him feel appreciated and loved. Grandpa loves his name.
Trader Joe's Candy Cane Joe-Joes are pure crack and I cave to them every year.	It is not sarcastic
What emojis (if any) would you add to this tweet?	Trader Joe's Candy Cane Joe-Joes are pure crack and I cave to them every year.
"Synthwave communities really love pessimism don't they haha Any upbeat energy and people get upset at ya"	It is not sarcastic
What emojis (if any) would you add to this tweet?	"Synthwave communities really love pessimism don't they haha Any upbeat energy and people get upset at ya"
@avsmph But how can we possibly deal with a human experience we haven't first relentlessly quantified???	It is sarcastic
What emojis (if any) would you add to this tweet?	@avsmph But how can we possibly deal with a human experience we haven't first relentlessly quantified???
Do you have any comments you would like to make?	

Participant Number	85
Question	Response
Qualification questions	
Consent to participate.	Yes
Are you over 18?	Yes
Do you use emojis?	Yes

Demographic Questions	
What is your gender?	Male
What age are you?	35-44
What is sarcasm?	Telling people what you really think in a way that doesn't sound insulting
Emoji Usage Questions	
The Drew Barrymore Show is an absolute trainwreck. Like The Tony Danza Show, every two minutes is a clip for The Soup.	It is not sarcastic
What emojis (if any) would you add to this tweet?	The Drew Barrymore Show is an absolute trainwreck. Like The Tony Danza Show, every two minutes is a clip for The Soup.
At the point in my life where my body keeps developing new allergies. My metabolism has slowed, hangovers are no joke anymore, and now I can't eat several of my favorite fruits. Screw wrinkles, this is the reason why people are afraid of getting old	It is not sarcastic
What emojis (if any) would you add to this tweet?	At the point in my life where my body keeps developing new allergies. My metabolism has slowed, hangovers are no joke anymore, and now I can't eat several of my favorite fruits. Screw wrinkles, this is the reason why people are afraid of getting old
Sitting on our new leather sofa, windows open, rain outside, candle burning, Sex and the City on, glass of rose in hand. This is it. This is a pure vibe.	It is not sarcastic
What emojis (if any) would you add to this tweet?	Sitting on our new leather sofa, windows open, rain outside, candle burning, Sex and the City on, glass of rose in hand. This is it. This is a pure vibe.
Turned 25 today but woke up with \$600 from the IRS in my bank account so quarter life crisis has been postponed	It is not sarcastic
What emojis (if any) would you add to this tweet?	Turned 25 today but woke up with \$600 from the IRS in my bank account so quarter life crisis has been postponed
Only a a President as strong and decisive as @realDonaldTrump would force the FDA to OK a drug even before clinical trial results are in. No need to wait for such silly formalities - people have been taking the drug for years and most are still alive and fine! #OkToTry #Gotrump https://t.co/IdxTJ7kucp	It is sarcastic

What emojis (if any) would you add to this tweet?	Only a a President as strong and decisive as @realDonaldTrump would force the FDA to OK a drug even before clinical trial results are in. No need to wait for such silly formalities - people have been taking the drug for years and most are still alive and fine! #OkToTry #Gotrump https://t.co/IdxTJ7kucp 🙄
@HawleyMO Please DO YOUR JOB or resign. Enough is enough.	It is not sarcastic
What emojis (if any) would you add to this tweet?	@HawleyMO Please DO YOUR JOB or resign. Enough is enough.
@rolandsmartin @nypost Damn! At my wedding we drank enough to make up for the no shows!	It is not sarcastic
What emojis (if any) would you add to this tweet?	@rolandsmartin @nypost Damn! At my wedding we drank enough to make up for the no shows!
I reverse imaged searched a selfie and it under visually similar images it is exclusively asian woman my am I white passing narrative is quaking	It is not sarcastic
What emojis (if any) would you add to this tweet?	I reverse imaged searched a selfie and it under visually similar images it is exclusively asian woman my am I white passing narrative is quaking
Do you have any comments you would like to make?	

Participant Number	86
Question	Response
Qualification questions	
Consent to participate.	Yes
Are you over 18?	Yes
Do you use emojis?	Yes
Demographic Questions	
What is your gender?	Female
What age are you?	25-34
What is sarcasm?	mix between a joke and an insult
Emoji Usage Questions	
was not aware that Crocs were appropriate business casual attire.	It is sarcastic
What emojis (if any) would you add to this tweet?	was not aware that Crocs were appropriate business casual attire. 😏

Are GoFundMe accounts a form of socialism? I dont have enough money to pay my bills, so let me create an account an ask for money to help pay my bills. ??	It is not sarcastic
What emojis (if any) would you add to this tweet?	Are GoFundMe accounts a form of socialism? I dont have enough money to pay my bills, so let me create an account an ask for money to help pay my bills. ??
not to alarm anyone but i just saw spider-man by uta	It is not sarcastic
What emojis (if any) would you add to this tweet?	not to alarm anyone but i just saw spider-man by uta
"youve heard of coffee enemas now get ready for coffee bidets"	It is not sarcastic
What emojis (if any) would you add to this tweet?	"youve heard of coffee enemas now get ready for coffee bidets"
its my party and ill shit if i want to	It is not sarcastic
What emojis (if any) would you add to this tweet?	its my party and ill shit if i want to
Tell the liverpool players to get some beers and just sit on the grass for the full 90 mins. Let leeds score as many goals as they want. #NoToEuropeanSuperLeague	It is sarcastic
What emojis (if any) would you add to this tweet?	Tell the liverpool players to get some beers and just sit on the grass for the full 90 mins. Let leeds score as many goals as they want. 🤔 #NoToEuropeanSuperLeague
Imagine not liking football	It is not sarcastic
What emojis (if any) would you add to this tweet?	Imagine not liking football ☐
HmMMMmMM four days off for the holiday + crappy weather = mini personal writing retreat? I like it.. I like it a lot	It is not sarcastic
What emojis (if any) would you add to this tweet?	HmMMMmMM four days off for the holiday + crappy weather = mini personal writing retreat? I like it.. I like it a lot 😊

why am I so tired and also why is the answer always chronic pain???!???	It is not sarcastic
What emojis (if any) would you add to this tweet?	why am I so tired and also why is the answer always chronic pain???!??? 😭😭😭
@catboychika Aren't you happy I gave you less competition for ranking	It is not sarcastic
What emojis (if any) would you add to this tweet?	@catboychika Aren't you happy I gave you less competition for ranking 😊
Do you have any comments you would like to make?	no

Participant Number	87
Question	Response
Qualification questions	
Consent to participate.	Yes
Are you over 18?	Yes
Do you use emojis?	Yes
Demographic Questions	
What is your gender?	Female
What age are you?	25-34
What is sarcasm?	Saying something that usually has ill-intent to the recipient but not framing it in a way that that is clear
Emoji Usage Questions	
was not aware that Crocs were appropriate business casual attire.	It is sarcastic
What emojis (if any) would you add to this tweet?	was not aware that Crocs were appropriate business casual attire. 😞
I just love when Twitter decides to reload the timeline seconds after you just opened it up and are in the middle of reading it.	It is sarcastic
What emojis (if any) would you add to this tweet?	I just love when Twitter decides to reload the timeline seconds after you just opened it up and are in the middle of reading it. 🙄

somebody tell these birds to be quiet because they not listening to me	It is sarcastic
What emojis (if any) would you add to this tweet?	somebody tell these birds to be quiet because they not listening to me 🗣️
@luka7doncic anyway youd want to come to the Jazz?	It is not sarcastic
What emojis (if any) would you add to this tweet?	@luka7doncic anyway youd want to come to the Jazz? 😊
You know its bad when your vet texts you to check in on your dogs diet #thicc	I don't know
What emojis (if any) would you add to this tweet?	You know its bad when your vet texts you to check in on your dogs diet #thicc 🤔
this bruh rly told me Ur anger issues are my playgroun so uhh hmu if u wana be friends bc i need new ones k thx(:	I don't know
What emojis (if any) would you add to this tweet?	this bruh rly told me Ur anger issues are my playgroun so uhh hmu if u wana be friends bc i need new ones k thx(:
this just in: phobias CAN be chosen and you CAN get rid of them by just not being scared!	It is sarcastic
What emojis (if any) would you add to this tweet?	this just in: phobias CAN be chosen and you CAN get rid of them by just not being scared! 😊
If Nick Lachey wins TMS I will be so bitter.	I don't know
What emojis (if any) would you add to this tweet?	If Nick Lachey wins TMS I will be so bitter.
recording myself talking in spanish and then having to listen to it back is seriously one of the most painful things in my life	I don't know
What emojis (if any) would you add to this tweet?	recording myself talking in spanish and then having to listen to it back is seriously one of the most painful things in my life

<p>every time i send my mom pictures of me and one of my friends doing fun things the first question she asks is if we're on a date what are you trying to tell me mother</p>	<p>I don't know</p>
<p>What emojis (if any) would you add to this tweet?</p>	<p>every time i send my mom pictures of me and one of my friends doing fun things the first question she asks is if we're on a date what are you trying to tell me mother 🙈</p>
<p>Do you have any comments you would like to make?</p>	

12 References

Abercrombie, G. and Hovy, D. (2016) 'Putting Sarcasm Detection into Context: The Effects of Class Imbalance and Manual Labelling on Supervised Machine Classification of Twitter Conversations', *University of Copenhagen* [Preprint].

Acheampong, F.A., Wenyu, C. and Nunoo-Mensah, H. (2020) 'Text-based emotion detection: Advances, challenges, and opportunities', *Engineering Reports*, 2(7). Available at: <https://doi.org/10.1002/ENG2.12189>.

Adamuthe, A.C. (2020) 'Improved Text Classification using Long Short-Term Memory and Word Embedding Technique', *International Journal of Hybrid Information Technology*, 13(1), pp. 19–32. Available at: <https://doi.org/10.21742/IJHIT.2020.13.1.03>.

Ahanin, Z. and Ismail, M.A. (2022a) 'A multi-label emoji classification method using balanced pointwise mutual information-based feature selection', *Computer Speech & Language*, 73, p. 101330. Available at: <https://doi.org/10.1016/J.CSL.2021.101330>.

Ahanin, Z. and Ismail, M.A. (2022b) 'A multi-label emoji classification method using balanced pointwise mutual information-based feature selection', *Computer Speech & Language*, 73, p. 101330. Available at: <https://doi.org/10.1016/J.CSL.2021.101330>.

Airaksinen, T. (2020) 'Irony and Sarcasm in Ethical Perspective', *Open Philosophy*, 3(1), pp. 358–368. Available at: <https://doi.org/10.1515/OPPHIL-2020-0132>.

Alon, D. and Ko, J. (2020) *GoEmotions: A Dataset for Fine-Grained Emotion Classification*, *Google Research*.

Anderson, D.J. and Adolphs, R. (2014) 'A framework for studying emotions across species', *Cell*, 157(1), pp. 187–200. Available at: <https://doi.org/10.1016/J.CELL.2014.03.003>.

Awal, A., Shoeb, M. and de Melo, G. (2020) *abushoeb/EmoTag: Emoji-Emotion dataset: An emoji-centric NLP resources based on Twitter Data*. Available at: <https://github.com/abushoeb/EmoTag/tree/master> (Accessed: 20 September 2023).

Awal, A., Shoeb, M. and De Melo, G. (2020) 'EmoTag1200 : Understanding the Association between Emojis and Emotions', *Proceedings of the 2020 Conference on Empirical Methods in Natural Language Processing*, pp. 8957–8967. Available at: <http://emoji.nlproc.org> (Accessed: 24 September 2023).

Bamman, D. and Smith, N.A. (2015) 'Contextualized Sarcasm Detection on Twitter', *Proceedings of the International AAAI Conference on Web and Social Media*, 9(1), pp. 574–577. Available at: <https://doi.org/10.1609/ICWSM.V9I1.14655>.

Barbieri, F. *et al.* (2020) 'Findings of the Association for Computational Linguistics TWEETVAL: Unified Benchmark and Comparative Evaluation for Tweet Classification', *Findings of the Association for Computational Linguistics* [Preprint]. Available at: <https://github.com/cardiffnlp/tweeteval> (Accessed: 24 September 2023).

Barrett, L.F. and Russel, J.A. (2015) *The psychological construction of emotion.*, *The Guilford Press*. Available at: <https://psycnet.apa.org/record/2014-10678-000> (Accessed: 22 April 2023).

Bolukbasi, T. *et al.* (2016) 'Man is to Computer Programmer as Woman is to Homemaker? Debiasing Word Embeddings', *Advances in Neural Information Processing Systems*, pp. 4356–4364. Available at: <https://arxiv.org/abs/1607.06520v1> (Accessed: 19 August 2023).

Botteri, D. (2016) 'Focus and Ellipsis in Split Questions: Syntax and Variation', *University of Siena* [Preprint]. Available at: https://www.academia.edu/29568516/Focus_and_Ellipsis_in_Split_Questions_Syntax_and_Variation (Accessed: 23 April 2023).

Bouazizi, M. and Ohtsuki, T. (2019) 'Multi-class sentiment analysis on twitter: Classification performance and challenges', *Big Data Min. Anal.*, 2(3), pp. 181–194. Available at: <https://doi.org/10.26599/BDMA.2019.9020002>.

Boutet, I. *et al.* (2021) 'Emojis influence emotional communication, social attributions, and information processing', *Computers in Human Behavior*, 119, p. 106722. Available at: <https://doi.org/10.1016/J.CHB.2021.106722>.

Briscoe, T. (1997) 'The Syntax and Semantics of Punctuation and its Use in Interpretation', *Cambridge University* [Preprint]. Available at: https://www.researchgate.net/publication/2284341_The_Syntax_and_Semantics_of_Punctuation_and_its_Use_in_Interpretation (Accessed: 12 May 2023).

Brown, L. (2013) "'Mind your own esteemed business": Sarcastic honorifics use and impoliteness in Korean TV dramas', *Journal of Politeness Research*, 9(2), pp. 159–186. Available at: <https://doi.org/10.1515/PR-2013-0008/MACHINEREADABLECITATION/RIS>.

Castelfranchi, C. and Miceli, M. (2018) 'Expectancy and Emotion', *Oxford University Press* [Preprint]. Available at: https://www.researchgate.net/publication/327558419_Expectancy_and_Emotion (Accessed: 22 April 2023).

Clark, H.H. and Fox Tree, J.E. (2002) 'Using uh and um in spontaneous speaking', *Cognition*, 84(1), pp. 73–111. Available at: [https://doi.org/10.1016/S0010-0277\(02\)00017-3](https://doi.org/10.1016/S0010-0277(02)00017-3).

Coelho, J. *et al.* (2021) 'Transformer-based Language Models for Semantic Search and Mobile Applications Retrieval', in *Proceedings of the 13th International Joint Conference on Knowledge Discovery, Knowledge Engineering and Knowledge Management*. SCITEPRESS - Science and Technology Publications, pp. 225–232. Available at: <https://doi.org/10.5220/0010657300003064>.

Cowen, A.S. *et al.* (2019) 'The primacy of categories in the recognition of 12 emotions in speech prosody across two cultures', *Nature human behaviour*, 3(4), pp. 369–382. Available at: <https://doi.org/10.1038/S41562-019-0533-6>.

Curto, G. *et al.* (2022) 'Are AI systems biased against the poor? A machine learning analysis using Word2Vec and GloVe embeddings', *AI and Society*, 1, pp. 1–16. Available at: <https://doi.org/10.1007/S00146-022-01494-Z/TABLES/3>.

Damasio, A.R. (1997) 'Neuropsychology. Towards a neuropathology of emotion and mood.', *Nature*, 386(6627), pp. 769–770. Available at: <https://doi.org/10.1038/386769A0>.

Darwin, C. (1872) *The expression of the emotions in man and animals*. London: John Murray. Available at: <https://doi.org/10.1037/10001-000>.

Davidov, D., Tsur, O. and Rappoport, A. (2010) 'Semi-Supervised Recognition of Sarcastic Sentences in Twitter and Amazon', *Proceedings of the Fourteenth Conference on Computational Natural Language Learning*, pp. 107–116. Available at: <http://tinysong.com/cO6i> (Accessed: 24 September 2023).

Dey, R. and Salemt, F.M. (2017) 'Gate-variants of Gated Recurrent Unit (GRU) neural networks', *2017 IEEE 60th International Midwest Symposium on Circuits and Systems (MWSCAS)*, 2017-August, pp. 1597–1600. Available at: <https://doi.org/10.1109/MWSCAS.2017.8053243>.

Dixon, S.J. (2023) 'Twitter in 2022: Global user statistics, demographics and marketing trends to know', *Insider Intelligence* [Preprint].

Dutta, S. and Mehta, A. (2021) 'Unfolding Sarcasm in Twitter Using C-RNN Approach', *Bulletin of Computer Science and Electrical Engineering*, 2(1), pp. 1–8. Available at: <https://doi.org/10.25008/BCSEE.V2I1.1134>.

Egger, R. and Yu, J. (2022) 'A Topic Modeling Comparison Between LDA, NMF, Top2Vec, and BERTopic to Demystify Twitter Posts', *Frontiers in Sociology*, 7. Available at: <https://doi.org/10.3389/fsoc.2022.886498>.

Eisner, B. *et al.* (2016) 'emoji2vec: Learning Emoji Representations from their Description', *University of London* [Preprint]. Available at: https://twitter.com/Kyle_MacLachlan/ (Accessed: 31 July 2023).

Eke, C.I., Norman, A.A. and Shuib, L. (2021) 'Context-Based Feature Technique for Sarcasm Identification in Benchmark Datasets Using Deep Learning and BERT Model', *IEEE Access*, 9, pp. 48501–48518. Available at: <https://doi.org/10.1109/ACCESS.2021.3068323>.

Ekman, P. (1992) 'Are there basic emotions?', *Psychological review*, 99(3), pp. 550–553. Available at: <https://doi.org/10.1037/0033-295X.99.3.550>.

Ekman, P. (2020) *Emotional Bias. Emotion and perception: How our emotions change how we see the world*, *Medium*. Available at: <https://paulekman.medium.com/emotional-bias-1576c97660a8> (Accessed: 23 April 2023).

Emojipedia (2023) *Emoji Statistics*, *Emojipedia*. Available at: <https://emojipedia.org/stats/> (Accessed: 12 May 2023).

Esuli, A. and Bond, F. (2022) *aesuli/SentiWordNet: The SentiWordNet sentiment lexicon*. Available at: <https://github.com/aesuli/SentiWordNet> (Accessed: 20 September 2023).

EU Parliament (2016) 'Regulation (EU) 2016/679 of the European Parliament and of the Council of 27 April 2016 on the protection of natural persons with regard to the processing of personal data and on the free movement of such data, and repealing Directive 95/46/EC (General Data Protection Regulation), Article 5: Principles relating to processing of personal data 2016 OJ L119/1', *European Parliament and Council of the European Union* [Preprint].

Fang, X., van Kleef, G.A. and Sauter, D.A. (2018) 'Person perception from changing emotional expressions: primacy, recency, or averaging effect?', *Cognition and Emotion*, 32(8), pp. 1597–1610. Available at: https://doi.org/10.1080/02699931.2018.1432476/SUPPL_FILE/PCEM_A_1432476_SM8405.DOCX.

Feldborg, M. *et al.* (2021) 'Perceiving the Self and Emotions with an Anxious Mind: Evidence from an Implicit Perceptual Task', *International Journal of Environmental Research and Public Health*, 18(22), p. 12096. Available at: <https://doi.org/10.3390/IJERPH182212096>.

Filatova, E. (2012) 'Irony and Sarcasm: Corpus Generation and Analysis Using Crowdsourcing', *Fordham University* [Preprint]. Available at: <http://storm.cis.fordham.edu/> (Accessed: 12 May 2023).

- Fontaine, J.J.R. (2013) 'Dimensional, basic emotion, and componential approaches to meaning in psychological emotion research', *Components of Emotional Meaning*, pp. 31–45. Available at: <https://doi.org/10.1093/ACPROF:OSO/9780199592746.003.0003>.
- Garg, A. and Duhan, N. (2020) 'Sarcasm Detection on Twitter Data using Support Vector Machine', *ICTACT JOURNAL ON SOFT COMPUTING*, (10), p. 4. Available at: <https://doi.org/10.21917/ijsc.2020.0308>.
- Gastwirth, J.L., Gel, Y.R. and Miao, W. (2009) 'The Impact of Levene's Test of Equality of Variances on Statistical Theory and Practice', *Statistical Science*, 24(3). Available at: <https://doi.org/10.1214/09-STS301>.
- Ghosh, A. and Veale, T. (2016) 'Fracking Sarcasm using Neural Network', *7th Workshop on Computational Approaches to Subjectivity, Sentiment & Social Media Analysis* [Preprint]. Available at: <https://doi.org/10.13140/RG.2.2.16560.15363>.
- Ghosh, D., Fabbri, A.R. and Muresan, S. (2017) 'The Role of Conversation Context for Sarcasm Detection in Online Interactions', *SIGDIAL 2017 - 18th Annual Meeting of the Special Interest Group on Discourse and Dialogue, Proceedings of the Conference*, pp. 186–196. Available at: <https://doi.org/10.18653/V1/W17-5523>.
- Gibbs, R. (2003) 'Nonliteral Speech Acts in Text and Discourse: Raymond W. Gibbs, Jr.', *Handbook of Discourse Processes*, pp. 358–394. Available at: <https://doi.org/10.4324/9781410607348-14>.
- Gibbs, R. and Colston, H. (2007) *Irony in language and thought: A cognitive science reader*. Lawrence Erlbaum Associates. Available at: <https://psycnet.apa.org/record/2007-10000-024> (Accessed: 12 May 2023).
- Gibbs, R.W. (1994) 'The Poetics of Mind: Figurative Thought, Language, and Understanding', *Journal of Pragmatics*, p. 527.
- Giora, R. (2012) 'On Our Mind: Salience, Context, and Figurative Language', *On Our Mind: Salience, Context, and Figurative Language*, pp. 1–272. Available at: <https://doi.org/10.1093/ACPROF:OSO/9780195136166.001.0001>.
- Giulianelli, M. (2017) *glnmario/emo2vec: Semi-supervised emotion lexicon expansion with label propagation and specialized word embeddings*. Available at: <https://github.com/glnmario/emo2vec/tree/master> (Accessed: 20 September 2023).

González-Ibáñez, R., Muresan, S. and Wacholder, N. (2011) 'Identifying Sarcasm in Twitter: A Closer Look', *The State University of New Jersey* [Preprint]. Available at: <http://www.vidarholen.net/contents/interjections/> (Accessed: 26 April 2023).

Grgić, D., Podobnik, V. and Carvalho, A. (2022) 'Deriving and validating emotional dimensions from textual data', *Expert Systems with Applications*, 198. Available at: <https://doi.org/10.1016/J.ESWA.2022.116721>.

Grice, H. (1975) *Logic and Conversation*, University of California, Berkley. Available at: <https://www.scribd.com/document/388176804/H-P-Grice-1975-Logic-and-conversation-pdf> (Accessed: 12 May 2023).

Grover, V. (2022) 'Exploiting Emojis in Sentiment Analysis: A Survey', *Journal of The Institution of Engineers (India)*, 103(1), pp. 259–272. Available at: <https://doi.org/10.1007/S40031-021-00620-7/METRICS>.

Gu, S. *et al.* (2015) 'Differentiation of Primary Emotions through Neuromodulators: Review of Literature', *International journal of neurology*, 1(2), pp. 43–50. Available at: <https://doi.org/10.17554/J.ISSN.2313-5611.2015.01.19>.

Hadi, A. (2013) 'A Critical Appraisal of Grice's Cooperative Principle', *Open Journal of Modern Linguistics* [Preprint]. Available at: <https://www.scirp.org/reference/ReferencesPapers.aspx?ReferenceID=766340> (Accessed: 12 May 2023).

Hand, C.J. *et al.* (2022) 'Interactions between text content and emoji types determine perceptions of both messages and senders', *Computers in Human Behavior Reports*, 8. Available at: <https://doi.org/10.1016/J.CHBR.2022.100242>.

Hiremath, B.N. and Patil, M.M. (2021) 'Sarcasm Detection using Cognitive Features of Visual Data by Learning Model', *Expert Systems with Applications*, 184, p. 115476. Available at: <https://doi.org/10.1016/J.ESWA.2021.115476>.

Hogenboom, A. *et al.* (2013) 'Exploiting emoticons in sentiment analysis', *Proceedings of the ACM Symposium on Applied Computing*, pp. 703–710. Available at: <https://doi.org/10.1145/2480362.2480498>.

Imbir, K.K. (2017) 'Psychoevolutionary Theory of Emotion (Plutchik)', *Encyclopedia of Personality and Individual Differences*, pp. 1–9. Available at: https://doi.org/10.1007/978-3-319-28099-8_547-1.

ISB (2018) 'Data Protection Act 2018', *Irish Statute Book* [Preprint].

Iseli, M. (2023) *Sarcasm in Japanese: Here's How It Works*, *Linguaholic*. Available at: <https://linguaholic.com/linguablog/sarcasm-in-japanese/> (Accessed: 23 April 2023).

Izard, C.E. (2007) 'Basic Emotions, Natural Kinds, Emotion Schemas, and a New Paradigm', *Perspectives on Psychological Science*, 2(3), pp. 260–280. Available at: <https://doi.org/10.1111/J.1745-6916.2007.00044.X>.

Jack, R.E., Garrod, O.G.B. and Schyns, P.G. (2014) 'Dynamic Facial Expressions of Emotion Transmit an Evolving Hierarchy of Signals over Time', *Current Biology*, 24(2), pp. 187–192. Available at: <https://doi.org/10.1016/J.CUB.2013.11.064>.

Jang, B. *et al.* (2020) 'Bi-LSTM Model to Increase Accuracy in Text Classification: Combining Word2vec CNN and Attention Mechanism', *Applied Sciences 2020, Vol. 10, Page 5841*, 10(17), p. 5841. Available at: <https://doi.org/10.3390/APP10175841>.

Jang, J., Sohn, H. and Lim, H.J. (2023) 'Spectral noise and data reduction using a long short-term memory network for nonlinear ultrasonic modulation-based fatigue crack detection', *Ultrasonics*, 129, p. 106909. Available at: <https://doi.org/10.1016/J.ULTRAS.2022.106909>.

Karthik, V., Nair, D. and Anuradha, J. (2018) 'Opinion Mining on Emojis using Deep Learning Techniques', *Procedia Computer Science*, 132, pp. 167–173. Available at: <https://doi.org/10.1016/J.PROCS.2018.05.200>.

Katz, G., Ofek, N. and Shapira, B. (2015) 'ConSent: Context-based sentiment analysis', *Knowledge-Based Systems*, 84, pp. 162–178. Available at: <https://doi.org/10.1016/J.KNOSYS.2015.04.009>.

Kaye, L.K., Wall, H.J. and Malone, S.A. (2016) "'Turn that frown upside-down": A contextual account of emoticon usage on different virtual platforms', *Computers in Human Behavior*, 60, pp. 463–467. Available at: <https://doi.org/10.1016/J.CHB.2016.02.088>.

Keltner, D. *et al.* (2019) 'Emotional Expression: Advances in Basic Emotion Theory', *Journal of Nonverbal Behavior* 2019 43:2, 43(2), pp. 133–160. Available at: <https://doi.org/10.1007/S10919-019-00293-3>.

Khotijah, S., Tirtawangsa, J. and Suryani, A.A. (2020) 'Using LSTM for Context Based Approach of Sarcasm Detection in Twitter', *ACM International Conference Proceeding Series* [Preprint]. Available at: <https://doi.org/10.1145/3406601.3406624>.

Kindma, D.P. and Lei Ba, J. (2015) 'Adam: A Method for Stochastic Optimisation', *International Conference on Learning Representations* [Preprint].

Kravitz, E.A. and Fernandez, M. de la P. (2015) 'Aggression in Drosophila', *Behavioral neuroscience*, 129(5), pp. 549–563. Available at: <https://doi.org/10.1037/BNE0000089>.

Kreuz, R.J. (2018) 'The Use of Verbal Irony: Cues and Constraints', *Metaphor: Implications and Applications*, pp. 23–38. Available at: <https://doi.org/10.4324/9781315789316-2>.

Kreuz, R.J. and Link, K.E. (2002) 'Asymmetries in the Use of Verbal Irony', *Journal of Language and Social Psychology*, 21(2), pp. 127-143+191. Available at: <https://doi.org/10.1177/02627X02021002002>.

Kreuz, R.J. and Roberts, R.M. (1995) 'Two Cues for Verbal Irony: Hyperbole and the Ironic Tone of Voice', *Metaphor and Symbolic Activity*, 10(1), pp. 21–31. Available at: https://doi.org/10.1207/S15327868MS1001_3.

Kumar, A. and Garg, G. (2019) 'Empirical study of shallow and deep learning models for sarcasm detection using context in benchmark datasets', *Journal of Ambient Intelligence and Humanized Computing*, pp. 1–16. Available at: <https://doi.org/10.1007/S12652-019-01419-7/METRICS>.

Kumon-Nakamura, S., Glucksberg, S. and Brown, M. (1995) 'How about another piece of pie: the allusional pretense theory of discourse irony.', *Journal of Experimental psychology. General*, 124(1), pp. 3–21. Available at: <https://doi.org/10.1037//0096-3445.124.1.3>.

Kunneman, F. et al. (2015) 'Signaling sarcasm: From hyperbole to hashtag', *Information Processing & Management*, 51(4), pp. 500–509. Available at: <https://doi.org/10.1016/J.IPM.2014.07.006>.

LeDoux, J.E. (1995) 'Emotion: clues from the brain', *Annual review of psychology*, 46, pp. 209–235. Available at: <https://doi.org/10.1146/ANNUREV.PS.46.020195.001233>.

LeDoux, J.E. (2012) 'Evolution of human emotion: A view through fear', *Progress in Brain Research*, 195, pp. 431–442. Available at: <https://doi.org/10.1016/B978-0-444-53860-4.00021-0>.

Lee Teh, P. and Pak, I. (2021) 'Pay to Play: Understanding Gamer's Motivation through Semantic Analysis', *ACM International Conference Proceeding Series*, pp. 168–175. Available at: <https://doi.org/10.1145/3487664.3487688>.

Majumdar, S. et al. (2021) 'Sarcasm Analysis and Mood Retention Using NLP Techniques', *International Journal of Information Retrieval Research*, 12(1), pp. 1–23. Available at: <https://doi.org/10.4018/IJIRR.289952>.

Mansourian, S. et al. (2016) 'Fecal-Derived Phenol Induces Egg-Laying Aversion in Drosophila', *Current Biology*, 26, pp. 2762–2769. Available at: <https://doi.org/10.1016/j.cub.2016.07.065>.

- Maynard, D. and Greenwood, M.A. (2014) 'Who cares about Sarcastic Tweets? Investigating the Impact of Sarcasm on Sentiment Analysis.', *University of Sheffield*, pp. 4238–4243. Available at: http://www.lrec-conf.org/proceedings/lrec2014/pdf/67_Paper.pdf (Accessed: 14 May 2023).
- Mesevage, T.G. (2021) *Guide to Data Labeling for AI*, MonkeyLearn. Available at: <https://monkeylearn.com/blog/data-labeling/> (Accessed: 23 April 2023).
- Michaelis, L.A. and Feng, H. (2015) 'What is this, sarcastic syntax?':, *Constructions and Frames*, 7(2), pp. 148–180. Available at: <https://doi.org/10.1075/CF.7.2.01MIC>.
- Mikolov, T. et al. (2013) *Word2Vec Google News Vectors*. Available at: <https://code.google.com/archive/p/word2vec/> (Accessed: 20 September 2023).
- Mohammad, S. (2022) *The NRC Emotion Intensity Lexicon*.
- Moore, B. and Mago, V. (2022) 'A Survey on Automated Sarcasm Detection on Twitter', *Lakehead University* [Preprint]. Available at: <https://arxiv.org/abs/2202.02516v1> (Accessed: 25 April 2023).
- Nafii, A., Bouezmarni, T. and Mesfioui, M. (2023) 'Non parametric multivariate distribution', *Communications in Statistics - Theory and Methods*, pp. 1–14. Available at: <https://doi.org/10.1080/03610926.2023.2251624>.
- Nandwani, P. and Verma, R. (2021) 'A review on sentiment analysis and emotion detection from text', *Social Network Analysis and Mining*, 11(1). Available at: <https://doi.org/10.1007/S13278-021-00776-6>.
- Netrapalli, P. (2019) 'Stochastic Gradient Descent and Its Variants in Machine Learning', *Journal of the Indian Institute of Science*, 99(2), pp. 201–213. Available at: <https://doi.org/10.1007/S41745-019-0098-4/METRICS>.
- Nguyen, A. et al. (2021) 'An Analysis of State-of-the-art Activation Functions For Supervised Deep Neural Network', *International Conference on System Science and Engineering (ICSSE)* [Preprint].
- Novak, K. et al. (2015) *Emoji Sentiment Ranking v1.0*. Available at: https://kt.ijs.si/data/Emoji_sentiment_ranking/ (Accessed: 20 September 2023).
- Novak, P.K. et al. (2015) 'Sentiment of emojis', *PLoS ONE*, 10(12). Available at: <https://doi.org/10.1371/JOURNAL.PONE.0144296>.
- Oprea, S. and Magdy, W. (2022) *dmbavkar/iSarcasm: A Dataset of Intended Sarcasm*. Available at: <https://github.com/dmbavkar/iSarcasm> (Accessed: 20 September 2023).

Pandey, P. (2021) *Analysis of Emotion Data: A Dataset for Emotion Recognition Tasks, Towards Data Science*. Available at: <https://towardsdatascience.com/analysis-of-the-emotion-data-a-dataset-for-emotion-recognition-tasks-6b8c9a5dfe57> (Accessed: 22 April 2023).

Pandey, R. and Singh, J.P. (2023) 'BERT-LSTM model for sarcasm detection in code-mixed social media post', *Journal of Intelligent Information Systems*, 60(1), pp. 235–254. Available at: <https://doi.org/10.1007/S10844-022-00755-Z/METRICS>.

Parde, N. and Nielsen, R. (2018) 'Detecting Sarcasm is Extremely Easy ;-)', *University of North Texas*, pp. 21–26. Available at: <https://doi.org/10.18653/V1/W18-1303>.

Parmar, K., Limbasiya, N. and Dhamecha, M. (2018) 'Feature based Composite Approach for Sarcasm Detection using MapReduce', *Proceedings of the 2nd International Conference on Computing Methodologies and Communication, ICCMC 2018*, pp. 587–591. Available at: <https://doi.org/10.1109/ICCMC.2018.8488096>.

Pavlitckaya, S., Oswald, J. and Zöllner, J.M. (2022) 'Measuring Overfitting in Convolutional Neural Networks using Adversarial Perturbations and Label Noise', *Proceedings of the 2022 IEEE Symposium Series on Computational Intelligence, SSCI 2022*, pp. 1551–1559. Available at: <https://doi.org/10.1109/SSCI51031.2022.10022094>.

Persicke, A. *et al.* (2013) 'Teaching children with autism to detect and respond to sarcasm', *Research in Autism Spectrum Disorders*, 7(1), pp. 193–198. Available at: <https://doi.org/10.1016/J.RASD.2012.08.005>.

Peters, J. (2022) *Figurative Language in Literature: Definition & Examples*, *SuperSummary*. Available at: <https://www.supersummary.com/figurative-language/> (Accessed: 23 April 2023).

Peters, M.E. *et al.* (2018) 'Deep contextualized word representations', *Proceedings of the 2018 Conference of the North American Chapter of the Association for Computational Linguistics: Human Language Technologies* [Preprint]. Available at: <http://allennlp.org/elmo> (Accessed: 12 May 2023).

Pillalamarri, A. and Cody, S. (2021) 'Online Content Regulation: An International Comparison', *International Law and Policy Brief* [Preprint].

Plutchik, R. (1962) *The emotions: facts, theories, and a new model*, *Random House*. Available at: https://openlibrary.org/books/OL5854888M/The_emotions_facts_theories_and_a_new_model (Accessed: 22 April 2023).

Potamias, R.A., Siolas, G. and Stafylopatis, A.-G. (2020) 'A transformer-based approach to irony and sarcasm detection', *Neural Computing and Applications*, 32(23), pp. 17309–17320. Available at: <https://doi.org/10.1007/s00521-020-05102-3>.

Prasad, A.G. *et al.* (2017) 'Sentiment analysis for sarcasm detection on streaming short text data', *2017 2nd International Conference on Knowledge Engineering and Applications, ICKEA 2017*, 2017-January, pp. 1–5. Available at: <https://doi.org/10.1109/ICKEA.2017.8169892>.

Prasanna, M.S.M., Shaila, S.G. and Vadivel, A. (2023) 'Polarity classification on twitter data for classifying sarcasm using clause pattern for sentiment analysis', *Multimedia Tools and Applications*, pp. 1–37. Available at: <https://doi.org/10.1007/S11042-023-14909-W/METRICS>.

Pudikov, A. and Brovko, A. (2021) 'Comparison of LSTM and GRU Recurrent Neural Network Architectures', in *Computer Science*, pp. 114–124. Available at: https://doi.org/10.1007/978-3-030-65283-8_10.

Qomariyah, S., Iriawan, N. and Fithriasari, K. (2019) 'Topic modeling Twitter data using Latent Dirichlet Allocation and Latent Semantic Analysis', in *The 2nd International Conference on Science, Mathematics, Environment and Education*. Available at: <https://doi.org/10.1063/1.5139825>.

Ramachandran, P., Zoph, B. and Quoc, V. Le (2017) 'Swish: A Self-Gated Activation Function', *Neural and Evolutionary Computing* [Preprint].

Rao, P. (2019) *Fine-grained Sentiment Analysis in Python, Towards Data Science*. Available at: <https://towardsdatascience.com/fine-grained-sentiment-analysis-in-python-part-1-2697bb111ed4> (Accessed: 22 April 2023).

Ren, Y., Ji, D. and Ren, H. (2018) 'Context-augmented convolutional neural networks for twitter sarcasm detection', *Neurocomputing*, 308, pp. 1–7. Available at: <https://doi.org/10.1016/J.NEUCOM.2018.03.047>.

Riordan, M.A. (2017) 'Emojis as Tools for Emotion Work: Communicating Affect in Text Messages', <http://dx.doi.org/10.1177/0261927X17704238>, 36(5), pp. 549–567. Available at: <https://doi.org/10.1177/0261927X17704238>.

Russell, J.A. (1980) 'A circumplex model of affect', *Journal of Personality and Social Psychology*, 39(6), pp. 1161–1178. Available at: <https://doi.org/10.1037/H0077714>.

Russell, J.A. and Barrett, L.F. (1999) 'Core affect, prototypical emotional episodes, and other things called emotion: dissecting the elephant', *Journal of personality and social psychology*, 76(5), pp. 805–819. Available at: <https://doi.org/10.1037//0022-3514.76.5.805>.

Saha, S., Yadav, J. and Ranjan, P. (2017) 'Proposed Approach for Sarcasm Detection in Twitter', *Indian Journal of Science and Technology*, 10(25), pp. 1–8. Available at: <https://doi.org/10.17485/IJST/2017/V10I25/114443>.

Saravia, E. *et al.* (2021) 'CARER: Contextualized Affect Representations for Emotion Recognition', *National Tsing Hua University*, pp. 3687–3697.

Schuff, H. *et al.* (2017) 'Annotation, Modelling and Analysis of Fine-Grained Emotions on a Stance and Sentiment Detection Corpus', *University of Stuttgart* [Preprint]. Available at: <http://www.ims.uni-stuttgart.de/data/> (Accessed: 12 May 2023).

Sclocchi, A. and Wyart, M. (2023) 'On the different regimes of Stochastic Gradient Descent'.

Sharma, D.K. *et al.* (2023) 'Sarcasm Detection over Social Media Platforms Using Hybrid Ensemble Model with Fuzzy Logic', *Electronics 2023, Vol. 12, Page 937*, 12(4), p. 937. Available at: <https://doi.org/10.3390/ELECTRONICS12040937>.

Sharma, D.M. *et al.* (2019) 'An LSTM-Based Deep Learning Approach for Detecting Self-Deprecating Sarcasm in Textual Data', *South Asian University* [Preprint]. Available at: <https://bit.ly/2WsUkUk> (Accessed: 24 April 2023).

Socher, R. *et al.* (2013) 'Recursive Deep Models for Semantic Compositionality Over a Sentiment Treebank', *Stanford University* [Preprint]. Available at: <http://nlp.stanford.edu/> (Accessed: 12 May 2023).

Soni, S., Chouhan, S.S. and Rathore, S.S. (2022) 'TextConvoNet: a convolutional neural network based architecture for text classification', *Applied Intelligence* [Preprint]. Available at: <https://doi.org/10.1007/s10489-022-04221-9>.

Sperber, D. and Wilson, D. (1981) 'Pragmatics', *Cognition*, 10, pp. 281–286.

Stein, N.L. and Oatley, K. (2008) 'Basic emotions: Theory and measurement', <https://doi.org/10.1080/02699939208411067>, 6(3–4), pp. 161–168. Available at: <https://doi.org/10.1080/02699939208411067>.

Subramanian, J. *et al.* (2021) 'Exploiting Emojis for Sarcasm Detection', *Arizona State University* [Preprint]. Available at: <https://www.facebook.com/> (Accessed: 14 May 2023).

Sykora, M., Elayan, S. and Jackson, T.W. (2020) 'A qualitative analysis of sarcasm, irony and related #hashtags on Twitter', *Big Data and Society* [Preprint]. Available at: <https://doi.org/10.1177/2053951720972735>.

- Tang, X. *et al.* (2019) 'A Multi-scale Convolutional Attention Based GRU Network for Text Classification', in *2019 Chinese Automation Congress (CAC)*. IEEE, pp. 3009–3013. Available at: <https://doi.org/10.1109/CAC48633.2019.8996433>.
- Taraba, P. (2020) 'Word Replaceability Through Word Vectors', *SN Computer Science*, 1(3), pp. 1–6. Available at: <https://doi.org/10.1007/S42979-020-00164-5/TABLES/3>.
- Tay, Y. *et al.* (2018) 'Reasoning with sarcasm by reading in-between', *ACL 2018 - 56th Annual Meeting of the Association for Computational Linguistics, Proceedings of the Conference (Long Papers)*, 1, pp. 1010–1020. Available at: <https://doi.org/10.18653/V1/P18-1093>.
- Thamm, R.A. (2006) 'The Classification of Emotions', *Handbooks of Sociology and Social Research*, pp. 11–37. Available at: https://doi.org/10.1007/978-0-387-30715-2_2/COVER.
- Tsur, O., Davidov, D. and Rappoport, A. (2010) 'ICWSM - A Great Catchy Name: Semi-Supervised Recognition of Sarcastic Sentences in Online Product Reviews', *Proceedings of the International AAAI Conference on Web and Social Media*, pp. 162–169. Available at: <https://doi.org/10.1609/ICWSM.V4I1.14018>.
- Tungthamthiti, P., Shirai, K. and Mohd, M. (2016) 'Recognition of Sarcasm in Microblogging Based on Sentiment Analysis and Coherence Identification', *Journal of Information Processing* [Preprint]. Available at: <https://doi.org/10.11185/IMT.12.80>.
- Unicode Consortium (2023) *Full Emoji List 15.0*, Unicode Consortium. Available at: <https://unicode.org/emoji/charts/full-emoji-list.html> (Accessed: 12 May 2023).
- Utsumi, A. (2000) 'Verbal irony as implicit display of ironic environment: Distinguishing ironic utterances from nonirony', *Journal of Pragmatics*, 32(12), pp. 1777–1806. Available at: [https://doi.org/10.1016/S0378-2166\(99\)00116-2](https://doi.org/10.1016/S0378-2166(99)00116-2).
- Villasenor Alva, J.A. and Estrada, E.G. (2009) 'A Generalization of Shapiro–Wilk's Test for Multivariate Normality', *Communications in Statistics - Theory and Methods*, 38(11), pp. 1870–1883. Available at: <https://doi.org/10.1080/03610920802474465>.
- Wang, F. and Pereira, A. (2016) 'Neuromodulation, Emotional Feelings and Affective Disorders', *Mens sana monographs*, 14(1), pp. 5–29. Available at: <https://doi.org/10.4103/0973-1229.154533>.
- Wetzel, P.J. (2004) *Keigo in modern Japan : polite language from Meiji to the present*. University of Hawai'i Press.

Yoo, B. and Rayz, J. (2021) 'Understanding Emojis for Sentiment Analysis', *Proceedings of the International Florida Artificial Intelligence Research Society Conference, FLAIRS*, 34. Available at: <https://doi.org/10.32473/FLAIRS.V34I1.128562>.

Yusof, N.N., Mohamed, A. and Abdul-Rahman, S. (2019) 'Context Enrichment Model Based Framework for Sentiment Analysis', *Communications in Computer and Information Science*, 1100, pp. 325–335. Available at: https://doi.org/10.1007/978-981-15-0399-3_26/COVER.

Zhang, M., Zhang, Y. and Fu, G. (2016) 'Tweet Sarcasm Detection Using Deep Neural Network', *Singapore University of Technology and Design* [Preprint]. Available at: <https://dev.twitter.com> (Accessed: 24 April 2023).

Zheng, L.J., Mountstephens, J. and Teo, J. (2020) 'Four-class emotion classification in virtual reality using pupillometry', *Journal of Big Data*, 7(1), pp. 1–9. Available at: <https://doi.org/10.1186/S40537-020-00322-9/TABLES/3>.